

Review of Magnetic Fluids and Their Applications to Vibration Reduction

Authors' contributions

This work was carried out in collaboration among all authors. All authors read and approved the final manuscript.

ABSTRACT

Magnetic liquids are a kind of nano-scale functional material with fluidity and superparamagnetism, which is mainly composed of nano-magnetic particles, base liquids and surfactants. Its characteristics mainly include magnetization, levitation, magnetoviscous effect. Compared with the traditional vibration damper, the vibration damper used in spacecraft based on these features has the peculiarity of small volume, low quality, sensitive to inertial force, and does not rely on spacecraft to provide additional energy. There are successful application cases in foreign aerospace and other fields, while the domestic is limited to some theory and experiment, the practical application is less, the lack of in-depth study. More than half of spacecraft failures are caused by vibration, so it is necessary to reduce the vibration of spacecraft. This paper briefly introduces the composition, preparation and characteristics of magnetic liquids, and reviews the typical applications of magnetic liquids in vibration reduction from the 20th century to the present, including the research on vibration reduction of spacecraft, loudspeakers and workbenches.

Keywords: Damping applications; levitation characteristics; magnetic liquids composition; magnetic viscous characteristic; preparation; spacecraft vibration

1. INTRODUCTION

When complex spacecraft structures float freely in outer space, it is very easy to be affected by external interference and its own influence, which makes it produce different forms of vibration. These vibrations occurring in the space environment without atmospheric resistance are difficult to be attenuated, which to some extent affects the precision of precision instruments in the spacecraft, such as resolution, stability and other performance indicators, and even destroys the normal operation of the spacecraft [1-4]. Relevant data show that more than half of the spacecraft electronic equipment failures are caused by vibration [5]. Among them, the first artificial satellite launched by the United States in 1958 named "Explorer I", in the implementation of

its mission, the four large whip antenna elastic vibration, resulting in the satellite abnormal flip after enter into orbit, which let the exploration mission fail. In 1982, the United States launched a satellite named "Landsat-4", for space observation. Small vibrations caused by the solar panel drive system interfered with its equipment, distorting the observed images and degrading the image quality. In the same year, the solar panel of the technology test satellite " ETS-III" launched by Japan which shook under the drive of the solar panel, that caused the wobble of the satellite and greatly affected the normal operation of the satellite. For the Hubble Space Telescope launched in 1990, the alternating hot and cold environment in space induced the vibration of the large compliance mechanism of the telescope itself, and made the whole

telescope tremble, reducing the clarity of the picture taken. Causing a lot of human effort and money were spent [6]. It is not difficult to see that suppressing the vibration of flexible overhang structure of spacecraft has become an important and difficult problem in spacecraft design.

With the development of control methods [7], a variety of new materials and structures have been applied to restrain vibration. As a liquid magnetic material that can exist for a long time and stably at room temperature, stands out among many materials. The magnetic fluids can be controlled by the magnetic field, so that it will not float in the space environment, and the damping property of liquid viscous materials provides a new solution to the vibration problem of the flexible overhang structure of spacecraft. Compared with the traditional shock absorber [8,9], the magnetic fluid shock absorber, as a new type of passive vibration absorber, has the advantages of being sensitive to inertia force, compact structure, no mechanical friction, long life and no external energy supply. Some countries have carried on the research of magnetic fluid shock absorbers to the application stage. This paper briefly summarizes the composition and classification of magnetic fluids, elaborates the preparation methods of different types of magnetic fluids and applications of magnetic fluids in vibration reduction.

2. COMPOSITION ANALYSIS OF MAGNETIC FLUIDS

Magnetic fluids (MFs), which are also known as ferrofluids, are synthetic nanoscale new materials with special physical and chemical properties. It is a colloidal solution composed of solid phase particles, surfactants, and

base carrier liquids [10,11], which has the fluidity of a liquid and the magnetism of a solid [12]. The composition of the magnetic liquid is shown in Fig.1 .Because the solid particles have been doing irregular Brownian motion in the base carrier liquids, they constantly collide with each other, so that they can also be stably suspended in the base liquids under various physical fields (electric field, gravity field, magnetic field), without precipitation and aggregation [13]. It is currently the most practical liquid magnetic material and has gained rapid development since it was proposed. Nowadays, MFs are everywhere in the fields of machinery, aerospace, and electronics, and have gradually developed into an interdisciplinary, multi-field nanoscale functional material, which will also play an important role in biomedicine, chemical industry and other fields.

The size, material, shape, and percentage of magnetic particles play a crucial role in the magnetic properties of MFs. Common magnetic particles include Fe , Co , Ni , Fe_3O_4 , Fe_2O_3 etc. [14-17]. The base carrier liquids require low evaporation rate, low viscosity, high chemical stability, radiation resistance and temperature resistance [18]. In general, scientists use water, oil, organic solvent as the base liquids [19], usually according to its working environment to choose the appropriate base liquid. Surfactants usually require amphiphilic molecular structure, mainly to prevent the precipitation of magnetic particles due to agglomeration. And the selection of surfactants is in accordance with the choice of base liquids. The physical and chemical properties of the base liquids and the surfactants play a decisive role in the fluid properties of the MFs [20,21].

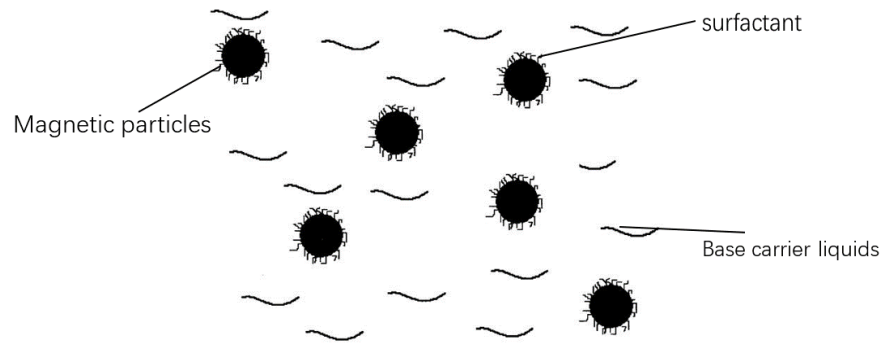

Fig.1. Composition of magnetic fluids

3. ANALYSIS OF PREPARATION

METHODS

Different particles have corresponding preparation methods, and MFs can be divided into ferrites, metals and ferrous nitride according to the properties of the particles. In the preparation process, nano-magnetic particles can be prepared first and then added to the surfactant and base liquids to prepare MFs, or MFs can be directly prepared. This article briefly describes some familiar methods for preparing MFs.

3.1 Preparation of Ferrofluids

3.1.1 Mechanical ball milling method

The ball milling method was proposed by S.S. Papell [22] in 1965 and was the earliest method used to prepare MFs. The principle is as follows: add a well-mixed magnetic particle and surfactant to the base carrier, put it into a ball mill to grind, put it into a centrifuge to remove the larger particles, and the magnetic fluids can be obtained. It is mainly under the action of mechanical forces (shear force, impact force, etc.) to allow magnetic particles to be sufficiently

dispersed in the medium. Ball milling method to prepare MFs requirements for raw materials are not strict, and the process is simple, crushed particles size can reach about 15nm [23], but the ball grinding method takes too long, low efficiency, ball grinding particle size distribution is uneven [24], difficult to use as mass production. So, it has not been used at present.

Since the advent of the ball milling method, scholars have also been continuously improved, Hong Ruoyu [25] and others proposed to first use the co-precipitation method to synthesize the Fe_3O_4 particles, and then put into the ball mill, after that add surfactant for ball grinding, and obtained a water-based MFs with good temperature resistance and dilution resistance. Some scientists have found that increasing the time of ball milling can improve the properties of magnetic fluids [26].

3.1.2 Chemical co-precipitation method

The chemical co-precipitation method was first proposed by Reimers et al. in 1972 [27], and has developed to the present and has become the most commonly used method. Taking the preparation of Fe_3O_4 as an example, Fig.2 shows the approximate steps of the preparation of this method.

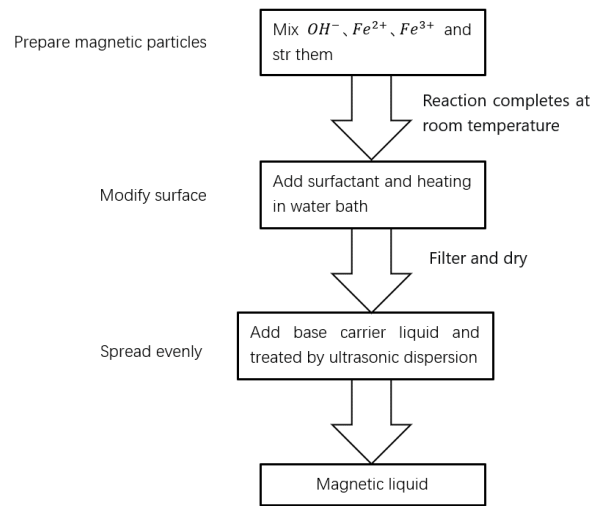
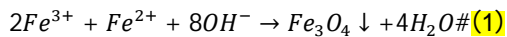

Fig.2. Steps for preparing MFs by co-precipitation

The preparation principle of this method can be expressed by the following formula:



The specific step is to take a certain proportion of the 2-valent ferrous salt solution and the 3-valent iron salt solution and mix it, then heat it in a water bath. And then add the alkaline precipitator ($NH_3 \cdot H_2O$, $NaOH$) to it, in order to ensure that the iron ions are completely precipitated, the pH of the mixed solution is controlled at 10. After dehydration and drying, add an appropriate amount of surfactant (such as oleic acid) to it and stir thoroughly to mix, the resulting magnetic particles are coated, and then transferred to the selected base liquid, by this way the ferrofluids are prepared. In the reaction process, Fe^{2+} in the air is easily oxidized to become Fe^{3+} , so in order to control the ratio of Fe^{3+} and Fe^{2+} into a reaction balance level, the divalent ferrous salt should be taken slightly more than the theoretical value, or add a small amount of iron filings into the ferrous solution. Whether the experimental product is pure or not is affected by the proportion of raw materials (Fe^{2+} , Fe^{3+}), the temperature set by the

water bath heating, the time and the stirring rate. To increase the saturated magnetization strength of MFs, other magnetic metal particles can be added during the preparation process.

Basak [28] believes that the best choice for preparing better quality cobalt ferrite nanoparticles is the chemical co-precipitation method. And he used this method to prepare $CoFe_2O_4$, and the sample obtained after calcination was made into magnetic fluids with a saturated magnetization intensity of up to $109 A \cdot m^2 / kg$. When preparing solid particles using chemical co-precipitation, the addition of alternating magnetic fields or ultrasonic waves [29] can make the preparation of magnetic particle sizes smaller.

The advantages of preparing MFs by co-precipitation method are that the reaction conditions are mild, the equipment is simple, and the preparation time is short, but the control requirements during the experiment are very strict [30].

3.2 Preparation of Metallic MFs

Most of the preparation of metal-type MFs

uses vacuum evaporation method, and the reaction device is shown in Fig.3.

Vacuum evaporation method was first proposed by Japanese scholars in the 1960s [31], and its reaction vessel needs to be pumped to a vacuum state, and then the mixed base liquids and surfactant are placed in the drum of the container, and the ferromagnetic metal is placed at the evaporation source. As the drum rotates, the mixed liquid is thrown onto the inner wall and forms a thin film, The ferromagnetic metal placed in the center of the cylinder is heated

to evaporated into a gaseous state, and these metal gas molecules fall on the liquid film and condensate due to thermal motion. It is coated with surfactant in the thin-film. The cylinder rotates non-stop, and the magnetic particles wrapped in the active agent are dissolved in the base carrier liquid under the reaction drum of container. At the same time, the mixed solution at the bottom also continuously provides a film of liquid for the reaction, so that the MFs are dispersed and stabilized repeatedly.

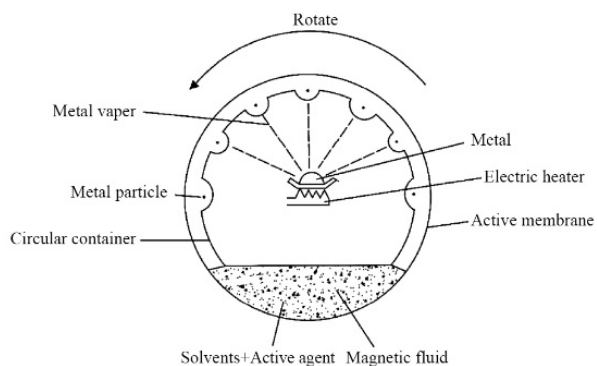

Fig.3. Vacuum evaporation method device diagram

The MFs prepared by this method has good dispersion and small particle size, but it is required vacuum when preparation, and the equipment requirements are strict.

3.3 Preparation of Ferrous Nitride MFs

3.3.1 Plasma CVD chemical vapor deposition method

The reaction principle apparatus diagram is shown in Fig.4, the base liquid is at the bottom of the container, the surfactant is dissolved in it, and the reaction process needs to be at a low pressure all the time. Organometallic compounds (e.g., $Fe(CO)_5$) that can be gasified and decomposed into metal particles under certain conditions are used as raw materials. During the reaction,

let the raw material gasified, then mixed with inert gases such as N_2 and Ar , and then entered the reactor through the nozzle to produce a low-temperature plasma under the stimulation of electric fields, microwaves or lasers. These gasified organometallic compounds can be decomposed into atoms or atomic groups by plasma, and the atomic groups collide in the container to form nanoparticles and move to the bottom at the same time [32,33], and are coated with surfactants in a mixed solution and evenly dispersed in the base carrier liquid to obtain a nitride ferromagnetic fluid.

In this reaction method, a ferrite magnetic fluid can also be prepared when a mixture of gases containing O_2 is inlet [34]. The production of MFs prepared by plasma

method have high efficiency, but the MFs equipments are too complex [35]. produced have poor performance and the

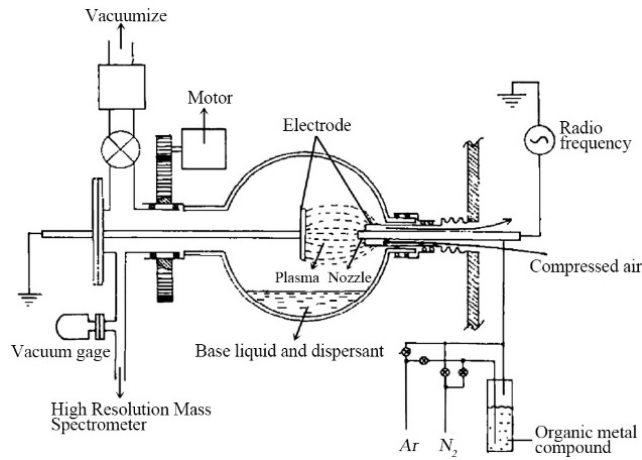

Fig.4. Plasma CVD preparation of nitride ferromagnetic fluids device [36]

3.3.2 Thermal decomposition method

The method is by adding a metal carbonyl complex ($M_x(CO)_y$, wherein $M = Ni, Fe, etc.$) or a mixture thereof, to a base liquid containing a surfactant. And then place them in a closed container which has a heating function, these metal carbonyl complexes are decomposed into granular metals under the action of heating, coated in a surfactant, and dispersed in the base liquid to obtain a magnetic fluid. The size of the solid particles produced by this way is nearly the same, but harmful gases are generated during the reaction, causing environmental pollution and also the manufacturing process is too complex. Both metallic MFs and ferromagnetic nitride MFs can be prepared by thermal decomposition [37].

In addition to these above methods, MFs can also be prepared by vapor-liquid phase reaction method, electrolytic deposition method, aqueous solution reduction method, and gas phase reduction method and so on [38].

4. STUDY ON PROPERTIES OF MFS

The main performance index of MFs usually refers to the magnetization (M_s) and viscosity η at high physical field and its operating temperature range. According to the working conditions, occasionally also consider vapor pressure and other physical and chemical parameters, but also shows superparamagnetic, no coercivity and remanence. When the content of magnetic particles in the MFs is in a small count, the viscosity, boiling point and density of the magnetic fluids are very close to the base liquids, and there is a big difference when the concentration is high. The main characteristics are as follows:

(1) Magnetization characteristics [39], subdomain size magnetic particles, can spontaneously magnetize to saturation, under the influence of thermal motion in the particle magnetic moment arbitrary orientation, but also in the MFs internal body force, and can be controlled, making it flow to a place where people are satisfied. Based on this superior performance, people have achieved successful applications in the fields

of MFs sealing and lubrication, and achieved accomplishments that cannot be achieved by traditional methods.

(2) Hydrodynamic properties. The hydrodynamic properties of MFs can be represented by the modified Bernoulli equation [40]

$$p + \frac{1}{2}\rho v^2 + \rho gh - \frac{1}{4\pi} \int_0^H M dH = K \# (2)$$

Where p , ρ , v , g , h , M , H represents the pressure, density, velocity, acceleration of gravity, height from datum, magnetization and strength of external magnetic field of the MFs respectively. The above formula shows that the sum of the pressure, kinetic energy, gravitational potential energy and magnetic energy of the MFs in motion is constant.

(3) Optical properties, the optical properties of MFs have birefringence phenomenon and dichroism phenomenon. Under the action of magnetic field, the particles of MFs are oriented, resulting in birefringence under the action of light. Dichroism is the natural light incident, will produce along the vertical direction and magnetization direction of two light, but along the magnetization direction of light is basically absorbed, using this property that MFs can be used as a polarizer.

(4) Viscosity, magnetic viscous characteristics of MFs [41,42] refer to the external magnetic field environment, will cause the solid particles to be rearranged, so that its viscous resistance increases, the apparent viscosity increases. The viscosity is not only affected by the strength of the magnetic field, the direction of the magnetic field also affects the size of the viscosity. The viscosity is greater when the external field is parallel to MFs flow direction than the vertical direction. Under the same environment temperature and the same magnetic field, the viscosity of the MFs increases with the increase of the magnetic field action time. When the time reaches a certain time, the viscosity of the magnetic fluid tends to be stable. When the temperature of the environment and the magnetic fluid is unchanged and the magnetic field acts on the magnetic fluid for a certain time, the viscosity of the MFs will increase exponentially with the increase of the magnetic field strength [43], as shown in Fig.5. Since the damping effect can be changed by the increase of its viscosity, the inertial damper, buffer and brake can also be realized by using MFs.

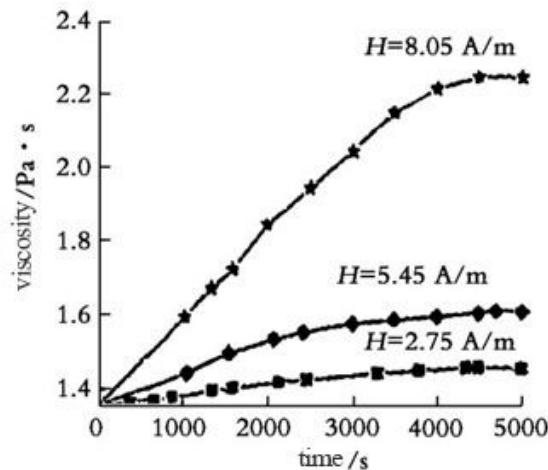

Fig.5. Viscosity of MFs changes with time

(5) Thermal effect [44], with the increase of temperature, the saturation magnetization of magnetic fluid gradually decreases, and it will disappear when the temperature drops to Curie temperature. Some magnetic fluids are also linearly dependent on temperature. Using this feature, MFs can be used as a temperature sensor, heat switch, etc.

(6) Levitation characteristics [45], refers to the MFs in the non-uniform magnetic field can put the density of larger than its own substance suspended up. According to the different suspended material, the magnetic fluid levitation characteristics can be divided into the first levitation principle and second levitation characteristic principle of ferrofluids, first levitation principle show that the non-magnetic material immersed in the ferrofluids can be stable suspended in it, is a kind of passive suspension. The second-order levitation property is that the permanent magnet can realize self-suspension in the ferrofluids, which is active suspension, and the two kinds of suspension are stable levitation, that is, the suspension will be stable for a long time under the condition that the magnetic field is unchanged.

5. ANALYSIS OF SHOCK ABSORBER APPLICATION

The field of magnetic fluids began in the 20th century when NASA successfully prepared stable magnetic fluids. A magnetic fluids damper (MFD) developed and designed by NASA in 1966 is shown in Fig.6 [46].

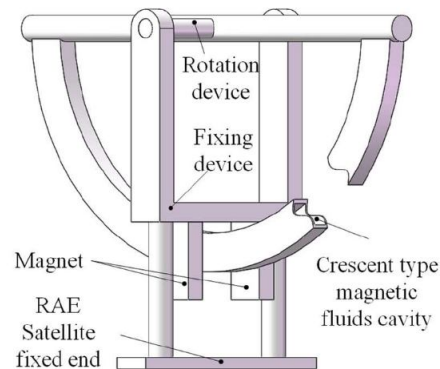

Fig.6. Schematic diagram of MFD

The damper is used to reduce the vibration and wobble caused by the internal dynamical system of the radio astronomical exploration satellite. The MFs is injected into the crescent-shaped container of the damper, and then the unfilled container is fixed to the truss protrusion structure. Two permanent magnets are placed on a rectangular frame on either side of the container. The rectangular frame and the crescent-shaped container are connected by springs.

The rectangular frame is attached at one end to the satellite and at one end to the truss protruding structure. When the satellite and the protruded structure move relative to each other, the magnetized magnetic fluid in the crescent-shaped container moves relative to the container under the action of the permanent magnet, and the viscous friction force is generated to suppress the relative motion between the truss and the satellite. The MFD has no friction between the mechanical components of traditional vibration reduction, which makes it very sensitive to low frequency and small amplitude vibration.

In 1973, a ferrofluids with low volatility was developed by an American company for vibration damping of moving coil

loudspeakers. Its structure is shown in Fig.7 [47].

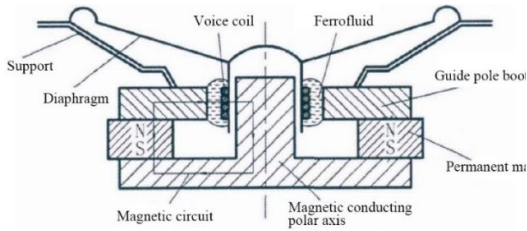

Fig.7. Moving coil loudspeaker vibration reduction

Because the moving coil loudspeaker has a natural resonant frequency, when the natural resonant frequency and the frequency of the electrical signal on the voice coil are the same, the voice coil drives the diaphragm vibration, then the resistance of the loudspeaker reaches the maximum. The existence of this resonance, so that the resonance summit of the moving coil loudspeaker makes the notes appear uneven. At the same time, there will be a vibration caused by the last electrical signal has not stopped, so that the next electrical signal input the speaker cannot respond in time.

When the ferrofluids are injected into the gap between the pole boots and the pole shaft, to reach resonance, the strong damping coefficient of ferrofluids under the control of the magnetic field can quickly reduce the resonance peak of the speaker, also better suppress the residual vibration of the voice coil, thus improving the corresponding instantaneous characteristics of the voice coil, greatly improving the performance of the moving coil loudspeaker. With the progress of the times, the application of ferrofluids in the loudspeaker is more and more extensive, such as the woofer, underwater acoustic system and so on, there are ferrofluids' figure.

In 1978, Moskowitz et al [48]. designed a

MFD for stepper motor by using the levitation characteristics of magnetic fluid in order to solve the shock problem caused by the reciprocating rotation of stepper motor. The structure is shown in Fig.8 as a magnetic fluid inertial damper designed based on the second levitation principle.

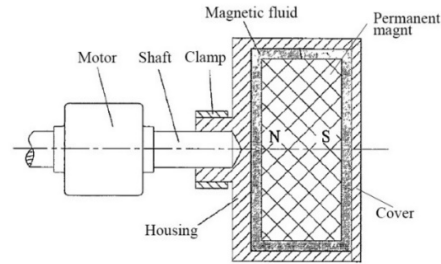

Fig.8. Magnetic fluid inertial damper

This structure doesn't have the mechanical structure of traditional inertial dampers. It is a cylindrical or ring permanent magnet suspended in a non-magnetic container filled with MFs. One end of the shaft is connected to the non-magnetic container and the other end is connected to the motor. When the motor vibrates, a relative motion occurs between the permanent magnet and the container. Using the viscous effect of the magnetic fluid to reduce the vibration and dissipate energy.

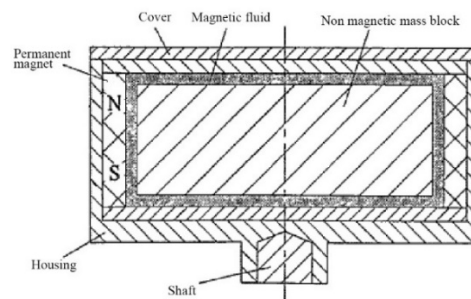

Fig.9. Magnetic fluid damper

The damper shown in Fig.9 is designed using the principle of first-order levitation of magnetic fluid, and is basically similar to the above structure, the biggest difference is that the suspended mass in the container is

non-magnetic material, and the magnetic field is provided by permanent magnets at both ends. The use of non-magnetic mass blocks makes it a wider range of material selection, which can avoid the possibility of mass block breakage due to excessive vibration.

In 1987, Nakatsuka of Japan designed a kind of piston type magnetic fluids damping vibration isolator. The device is shown in Fig.10 [49]. The structure is composed of multiple permanent magnets, a shell and an aluminum shaft piston. The permanent magnets are evenly distributed on the outer wall of the shell, separated by spacers, and the aluminum shaft piston is placed in the housing filled with MFs. When input by vibration, the aluminum shaft piston reciprocates in the shell, and uses the shear force generated by its motion and the suspension force provided by the levitation principle to achieve energy dissipation and vibration reduction. The structure requires high viscosity of the MFs, otherwise it is only suitable for vibration in a small frequency range. This vibration isolator is designed to reduce the impact of ground vibration on the table, and later has been widely used in precision balance, precision machining instruments.

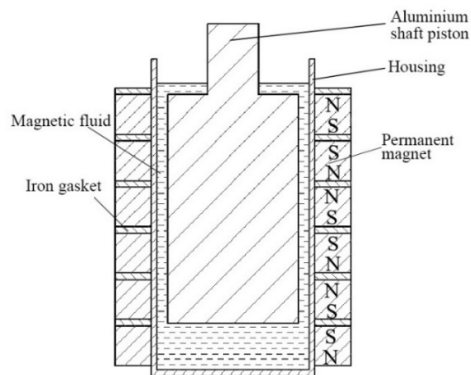

Fig.10. Piston type vibration isolator

In 1991, Kunio et al. modified the piston type

MFD isolator by using an electromagnetic coil instead of a permanent magnet and applying a spring to this type of shock absorber [50]. The structure is shown in Fig.11. The coil is wound on the coat, and the coil is energized to generate a magnetic field. The size of the magnetic field can be changed according to the change of the electric current, realizing the controllability of the magnetic field, which is a typical active control. Nano-sized magnetite or iron particles can be dispersed in the base carrier liquid to improve the viscosity and magnetization characteristics of the MFs, which can be well improved when applied to vibration reduction.

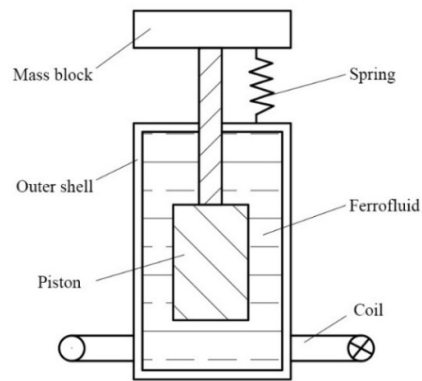

Fig.11. Electromagnetic magnetic fluid isolator

In 1990, Romanian scholar Piso designed an acceleration sensor using the first levitation principle of MFs [51,52], and in 2014, domestic scholar Wang Siqi improved it into a dynamic vibration absorber for local vibration reduction of spacecraft. Its structure is shown in Fig.12 [53].

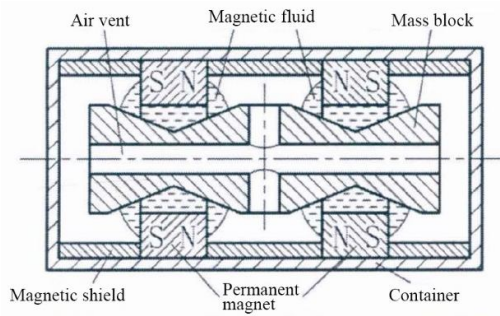

Fig.12. Magnetic fluid shock absorber with double cone angle

In this structure, the permanent magnet adopts axial magnetization, the two stages are fixed on the non-magnetic shell, separated by a certain distance with a magnetic insulation sleeve, and the inertia mass block is processed with a cone-angle structure, and suspended in the permanent magnet body hole. The symmetrical cone-angle structure can make the first levitation force produce axial component, so that it can be stably suspended in the center of the container when no vibration occurs. When there is vibration input, the mass block moves, and the axial component generated by the cone-angle structure provides the recovery force for the mass block, making the mass block finally return to the equilibrium position. The air vent can prevent additional pressure caused by compressed air during mass movement.

In 2003, French scholars designed a cylindrical ferrofluid dynamic shock absorber to control the vibration of a long rod by using the principle of the second levitation of magnetic fluids. The device is shown in Fig.13 [54]. The permanent magnet adsorbed on the ferrofluid is put into the container, so that the second-order buoyancy force generated by the magnet can overcome gravity and self-suspend in the container. The stopper can prevent the permanent magnet from falling out of the

container due to vibration, and the shock absorber can effectively suppress the free vibration of the long rod.

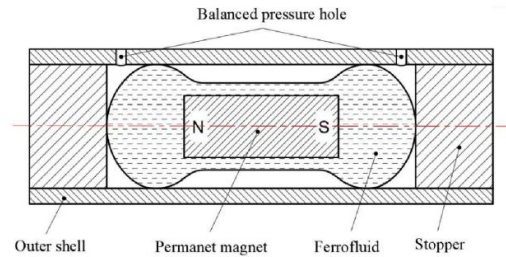

Fig.13. Cylindrical magnetic fluid damper absorber

In 2017, Yao Jie et al. designed a new magnetic fluid shock absorber based on the second levitation principle force of magnetic fluids, and its structure is shown in Fig.14 [55]. The vibration absorber attenuates by viscous energy dissipation generated by the relative motion between the magnetic fluid adsorbed by the supporting force permanent magnet and the inner wall of the shell. When the damping block is about to move to both ends of the shell, the closer it is to the restoring force permanent magnet, the greater the repulsive force will be, so the restoring force pointing to the center will be provided to the damping block. A small amount of magnetic fluid can be used to reduce the vibration of the absorber.

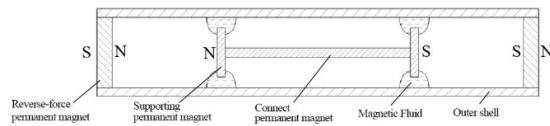

Fig.14. New magnetic fluid shock absorber

6. CONCLUSIONS

This paper briefly analyzes the adverse effects of vibration on spacecraft in service. Vibration reduction of long straight flexible structure is still the main research direction at

present. Then introduced the main characteristics of MFs and described their preparation methods. Also, the development of the damping application of the MFs were introduced from 1960s to nowadays.

Even though a variety of methods can be used to prepare MFs, the process is complex and the requirement of raw materials is so high. Also, it is very difficult to meet the requirements of low evaporation rate, high stability, high temperature resistance, and corrosion resistance at same time. The carrier liquids and dispersant of MFs can only be selected according to the required working conditions. Therefore, it is particularly important to develop new types of MFs that can meet the needs of various working environments. In addition, it is possible to develop a composite MFs in the future, combining the MFs with other multifunctional materials, such as graphene.

The preparation of MFs will be developed in the direction of simplified equipment, mass production and wide application.

At the same time, the MFs used in vibration reduction has the advantages of small size, sensitivity to inertial force, and no external excitation, which has a good effect on the suppression of spacecraft long straight flexible structure vibration. At present, some achievements have been made, and it will also be an important research direction of spacecraft vibration reduction in the future.

COMPETING INTERESTS

Authors have declared that no competing interests exist.

REFERENCES

1. Yongwei Ci, Dalu Qiu, Leping Fu, et al. Progress of spacecraft Vibration Test Control Technology. Dynamics and Journal of Control and Control, 2014(3):193-200. Chinese.
2. Tianle Tan, Chunyan Zhu, Dongfang Zhu, et al. Review on Measurement, Isolation and Suppression of Micro-Vibration in Space. Shanghai aerospace, 2014,31(6):36-45. Chinese.
3. Zhenxing Shen, Gengkai Hu. Study on thermal vibration of large spacecraft structures. Manned space flight, 2016,22 (1): 117-125. Chinese.
4. Wang H J, Wang W, Wang X, et al. Effect of spacecraft micro-vibration on image quality of space camera. Acta photonica sinica, 2013,42 (10): 1212-1217. Chinese.
5. Zhenhua Tang. Design and Application of Vibration Resistance and Isolation Technology for Aerospace Electronic Equipment. Electro-mechanical Engineering, 1994(02):21-29. Chinese.
6. Guoping Yuan, Xiaoping Shi, Long Li. Adaptive robust control and active vibration suppression of spacecraft attitude maneuver. Journal of vibration and shock, 2013,32(12):110-115. Chinese.
7. Hyland D C, Junkins J L, Longman R W. Active control technology for large and Dynamics , 1993, space structures. Journal of Guidance, Control,16(5):801-821.
8. H Y Ren. Application of viscoelastic Damping in Missile Impact Isolation Structure. Journal of astronautics, 2007,28 (6):1494-1499. Chinese.
9. Ye Yang, Wenxin Fan, Jingyi Tian. Design of metal rubber shock absorber. Coal technology, 2010, 29(12):29-31. Chinese.
10. Rosensweig R E. Magnetic fluids. Annual Review of Fluid Mechanics, 1966,19(1): 437-463.
11. Liu Silin, Teng Ronghou, Yu Yingyi. Preparation and application of magnetic liquid. Powder metallurgy industry,

- 2000,10(5):32-39. Chinese.
12. Neuringer J L, Rosensweig R E. Ferrohydrodynamics. *Physics of Fluids* (1958-1988),2004,7(12): 1927-1937.
 13. Decai Li. *Theory and Application of Magnetic Liquids*. Beijing: Science Press, 2003:1-27. Chinese.
 14. Zhang L, Huang Z, Shao H, et al. Effects of $\gamma - \text{Fe}_2\text{O}_3$ on $\gamma - \text{Fe}_2\text{O}_3/\text{Fe}_3\text{O}_4$ composite magnetic fluid by low-temperature low-vacuum oxidation method. *Materials and Design*, 2016, 105:234-239.
 15. Pate J, Parekh K, Upadhyay R V. Performance of Mn-Zn ferrite magnetic fluid in a prototype distribution transformer under varying loading conditions. *International Journal of Thermal Sciences*, 2017,114: 64-71.
 16. Šafařík I, Šafaříková M. *Magnetic nanoparticles and biosciences. Nanostructured Materials*. Springer. 2002:1-23.
 17. Li X H. *Nano-Magnetic liquid-Preparation, Properties and Application*. Beijing: Science Press, 2009:1-15. Chinese.
 18. Soares P I P, Lochte F, Echeverria C, et al. Thermal and magnetic properties of iron oxide colloids: influence of surfactants. *Nanotechnology*, 2015, 26 (42):425704.
 19. Afifah AN, Syahrullail S, Sidik N A C. Magnetoviscous effect and thermomagnetic convection of magnetic fluid: A review. *Renewable and Sustainable Energy Reviews*, 2016, 55:1030-1040.
 20. Puentes-Vara L A, Gregorio-Jauregui K M, Bolarín A M, et al. Effects of surfactant and polymerization method on the synthesis of magnetic colloidal polymeric nanoparticles. *Journal of Nanoparticle Research*, 2016, 18(7):212.
 21. Decai Li. *Theory and Application of Magnetic Liquid Seal*. Beijing: Science Press, 2010:1-2. Chinese.
 22. Papell S S. Low viscosity magnetic fluid obtained by the colloidal suspension of magnetic particles: 3215572.1965-11-02.
 23. Matsumoto K T, Hosokawa A, Hiraoka K. Magnetic and magnetocaloric properties in GdZn_2 synthesized by ball milling. *Journal of Rare Earths*, 2020, 20:481-486.
 24. Zhang G, Guodong Z, Jiaqi C, et al. Communication—magnetic properties of $\text{Fe}/\text{Na}_2\text{SiO}_3/\text{Fe}_3\text{O}_4$ soft magnetic composite by two-stage ball milling. *ECS Journal of Solid State Science and Technology*, 2020, 9(12):
 25. Hong R Y, Ren Z Q, Han Y P, et al. Rheological properties of water-based Fe_3O_4 ferrofluids. *Chemical Engineering Science*. 2007.
 26. Amiruddin E, Prayitno A. The synthesis of magnetic nanoparticles from natural iron sand of Kata beach Pariaman West Sumatera using ball milling method as environmental material. *MATEC Web of Conferences*, 2019, 276:1-5.
 27. Khalafalla S E, Reimers G W. *Production of Magnetic Fluids by Peptization Techniques*: 3843540.1972-10-22.
 28. Munmun B, Lutfur R M, Farid A M, et al. Calcination effect on structural morphological and magnetic properties of nano-sized CoFe_2O_4 developed by a simple co-precipitation technique. *Materials Chemistry and Physics*, 2021, 264: 1-11.
 29. Mohammad J E, Ir aj H. Size-controlled synthesis of Fe_3O_4 magnetic nanoparticles via an alternating

- magnetic field and ultrasonic-assisted chemical co-precipitation. *Materials Science & Engineering B*, 2021, 266: 1-10.
30. Wu K T, et al. *IEEE Transactions on Magnetics*. 2001,37(4):2651~2653.
 31. Kimoto K, Kamiya Y, Nonoyama M, et al. An electron microscope study on fine metal particles prepared by evaporation in argon gas at low pressure. *Japanese Journal of Applied Physics*, 1963, 2(11):702.
 32. Ioan Bica. *Materials Science and Engineering B*. 1999,68:5~9
 33. Ioan Bica. *Journal of Magnetism and Magnetic Materials*. 1999,201; 45~48.
 34. Li X H. Method and device for preparation of ferric nitride magnetic liquid by plasma: 200310105229.3. 2006-06-28. Chinese.
 35. Li X H, et al. *Surface & Coatings Technology*. 2007, 201,5371~5373. Chinese.
 36. Isao N, Takao F. Iron-nitride magnetic fluids prepared by plasma CVD technique and their magnetic properties. North-Holland, 1990, 85:11-13.
 37. Thomas J R. Preparation and magnetic properties of colloidal cobalt particles. *Journal of Applied Physics*, 1966, 37:2913-2915.
 38. Ladislau V. *China Particuology*. 2007,5;43~49. Chinese.
 39. Odenbach S. Recent progress in magnetic fluid research. *Journal of physics: condensed matter*, 2004, 16(32): R1135.
 40. Chi Changqing. *Ferrofluid Dynamics*. Beijing University of Aeronautics and Astronautics Press, 1993.
 41. Odenbach S, Thurm S. *Magnetoviscous effects in ferrofluids* Ferrofluids. Springer, Berlin, Heidelberg, 2002: 185-201.
 42. Pinho M, Brouard B, G enevaux J M, et al. Investigation into ferrofluid magnetoviscous effects under an oscillating shear flow. *Journal of magnetism and magnetic materials*, 2011,323(18-19):2386-2390.
 43. Yuly V Milman. The influence of porosity on mechanical properties of sintered material. *Sinter and Material*, 1995, 26:49 — 53.
 44. Teng Ronghou. Discussion on Magnetic Liquid. *Powder Metallurgy Industry*, 2001(05):48-49. Chinese.
 45. Rosensweig R E. Buoyancy and stable levitation of a magnetic body immersed in a magnetizable fluid. *Nature*, 1966,210(5036): 613-614.
 46. Missiles A. Feasibility study and model development for a ferrofluid viscous damper Final report. Massachusetts: Space and Electronics Group, 1967: 1-84.
 47. King J A. Method for making loudspeaker with magnetic fluid enveloping the voice coil. U.S., A, 4,017,694.1977-04-12
 48. Moskowitz R, Stahl P, Reed W R. Inertia damper using ferrofluid. 1978.
 49. Fukuda H, Ueno K, Kamiyama S, et al. Study on Active Damper with a Magnetic Fluid. *Transactions of the Japan Society of Mechanical Engineers Series B*, 1997,63(616): 3891-3898
 50. Shimada K, Kamiyama S. A Basic Study on Oscillatory Characteristics of Magnetic Fluid Viscous Damper. *Transactions of the Japan Society of Mechanical Engineers Series B*, 1991, 57(544):4111-411
 51. Piso M I. Magnetofluidic inertial sensors. *Romanian reports in physics*, 1995, 47:437-454.
 52. Piso M I, V ek as L. Magnetic fluid

composites and tools for microgravity experiments. *Journal of Magnetism and Magnetic Materials*, 1999, 201(1):410-412.

53. Wang Siqi, Li Decai, Chang Jianjun. A Kind of Magnetic Liquid Damping Shock Absorber with Hourglass-like Non-magnetic Inertia Block. CN, A, 10423524.8.2014-08-01. **Chinese.**
54. Wang Z, Bossis G, Volkova O, et al. Active control of rod vibrations using magnetic fluids. *Journal of Intelligent Material Systems and Structures*, 2003,14(2): 93-97.
55. Yao J, Chang J, Li D. A novel magnetic fluid shock absorber with levitating magnets. *Journal of Vibroengineering*, 2017,19(1): 28-37.