

Tennis throwing machine voice control via Bluetooth of an Arduino-based and using PI Controller

Abstract:

All training methods in tennis agree that through repetitive training on certain points and distances of the ball, the player's skills improve, and he acquires new blocking techniques. This throwing machine helps in the repetitive training.

Previous studies on this machine, but our topic is somewhat different. We have added the technology of voice control and training on specific points and places, in contrast to random throwing, where the player can control the machine by sending a voice message via the smartphone, with the presence of Bluetooth and Arduino. The basic devices in our project are High-efficiency electric drives required for emerging technologies. PI controllers are used to control the motors' speed.

Proteus 8 professional was used for simulation, Arduino code was written using the programming language Arduino IDE, MATLAB simulation for the PI controller, and the Android applications were created using the MIT app inventor

The electrical circuit of the machine will be tested to demonstrate the entire project and to check the control result.

Keywords: PI controller, H-bridge, MIT app, Arduino, Hall magnetic sensor ...

1. Introduction:

The tennis ball machine has a brief history, the first hand-cranked tennis ball machine, dubbed "lance-balle." Lacoste was a perfectionist who was chastised by his own coach for overtraining. His training rigor was tiring for his partners, so he decided to build a ball-throwing machine to keep his edge. Someone on the opposing side of the court hand-cranked this machine [1], Tomá Kob, Jan Carboch, and Vladimr Süss. [2] They considered the machine to be an impediment to the player when compared to playing against a human opponent.

and Bob McClure was the inventor of the first electronic tennis ball machine. by reversing the motor on his vacuum cleaner. The machine works by using vacuum cleaner pressure to propel a tennis ball out of a connection tube. McClure named his invention the "Little Prince," and the machine's success led to the establishment of the

Prince Manufacturing Company [3]. In the same context, Perumalsamy and colleagues [4] created an automated volleyball throwing machine. the velocity and movement of the ball, they programmed repeatable path following of the ball using Solid Works and AutoCAD software. In their study, Saal et al. [5], [6] developed the "Footbonaut" measurement system, which was to control the movement speed that could be diagnosed and trained, and it was stated that with this system, the existing talent identification and skills development structure of football players will be strengthened.

All previous studies agree that all training approaches in tennis are that by repeating in blocking some strikes the player acquires techniques and skills that make him quick to deal with all throws. What machine designers might criticize based on random throws. This may differ from previous studies, as we did not rely on random strikes because the idea of our work is to

control the device by sending a voice message via the smartphone, and this allows the player to exercise all the time and without the need for a player or another partner or a device that hinders the speed of training.

In the first part of this article, we will discuss the elements used in the electrical circuit of the machine, and in the second part, the theoretical methodology, while simulation and practical results are in the last part.

The electrical part:

in the electrical circuit of this tennis throwing machine, there are three main components, on top of which are the Arduino and the h-bridge, as well as the two DC motors and other secondary components, including servo motors, as well as the Bluetooth, a sensor to measure the rotational speed of the motors, an LCD screen to display the results, and a smartphone to send commands and a battery as a power source.

The Arduino board is based on an integrated circuit (a mini-computer also called a microcontroller) associated with inputs and outputs that allow the user to connect different types of external elements, **The Arduino Mega 2560** board is a microcontroller board based on an ATmega2560. It contains everything necessary for the operation of the microcontroller; The ATmega 2560 has 256KB of FLASH memory to store the program. [6]

The KesKinler Motor KG555, 12V 13000 RPM, DC motor used in this system is a powerful geared motor, this motor is linked to a Hall Effect magnetic sensor, which serves as a sensor and serves as a feedback path for the developed PID system. which will measure the pulses due to rotation of the shaft.

The hall magnetic sensor: In engine systems, this sensor measures wheel/rotor speed or RPM as well as the position of the crankshaft or camshaft. These sensors are made up of a Hall Element and a permanent magnet that is attached

to the rotating shaft's toothed disk. The distance between the sensor and the disk's teeth is very small. As a result, each time a tooth passes near the sensor, the surrounding magnetic field changes, causing the sensor's output to be either high or low. As a result, the sensor's output is a square wave signal that can be easily used to calculate the RPM of the rotating shaft. [7]

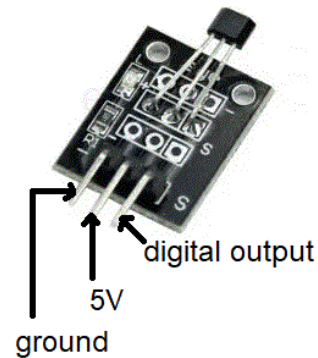

Fig1: hall magnetic sensor

Note: The DC motor cannot be connected directly to the Arduino. This is due to the motor's need for a high current[8], which the Arduino cannot provide. As a result, we'll use the entire **H-bridge** as a circuit between the Arduino and the motor.

Using an H-bridge motor allows us to effectively control the direction and speed of motors. It is very common in industrial motor control, and it is also very simple to do with Arduino.

The Bluetooth: When the Bluetooth unit receives data from the device with which it is associated (computer or smartphone), it sends it to the Arduino board via the Rx and Tx pins. We selected the **HC-05 Bluetooth** module.

2. The Methodology and Modeling System:

as we mentioned in the introduction that through repetition and training on certain points, the level of the player rises through the acquisition of tactical and quick skills, so we tried to focus on 9

positions of the ball in order to practice playing through this machine.

The Arduino receives the voice messages coming from the Android application via Bluetooth, and it is translated according to the program in the memory of the Arduino board and translates these commands after verification and translates them into a signal and turns it into an h-bridge connected to two DC motors. by Pressure and Friction Force The ball is thrown in the direction of the desired point to be reached. The wheels are fixed on a holder connected to a servo motor. The wheels holder rotates in the desired direction.

These points are distributed on the field regularly from right to left for not to be lost the ball and does not go out of the playground, to calculate the maximum angle of the machine that can be taken in order to shoot:

$$\tan\left(\frac{Q}{2}\right) = \frac{\frac{M_3}{2}}{M_1 - M_4} = \frac{M_3}{2(M_1 - M_4)}$$

$$Q = 2 \tan^{-1}\left(\frac{M_3}{2(M_1 - M_4)}\right)$$

When:

$$M_2 = 23.77\text{m (length of tennis playground)}$$

$$M_1 = \frac{M_2}{2} = 11.885 \text{ m}$$

$$M_3 = 8.2\text{m (width of tennis playground)}$$

$$M_4 = M_1 - \text{the pitch grid height (0.91m)} = 11.885 - 0.91 = 10.975 \text{ m}$$

So, if the instrument is in one of the mid-points of the field:

$$Q_{max} = 2 \tan^{-1}\left(\frac{M_3}{2(M_1 - M_{4max})}\right) \cong 155^\circ$$

As a result, the maximum angle that can be taken to throw the ball to the right is 77° , and the maximum angle that can be taken to throw the ball to the left is 77° as far as possible.

We decided that the initial velocity of the ball should be the same as the velocity of the wheels after ignoring friction and the effect of air.

$$v_{imax} = rpm_{max} * r * 2\pi * 60$$

v_i is the initial velocity of the ball (klm/h) (the velocity of the wheels), r is the wheel diameter, rpm_{max} of the dc motor.

To calculate the distance of the ball (m):

$$R = \frac{v_i^2 \sin(2\theta)}{g}$$

v_i is the initial velocity of the ball (m/s) (the speed of the wheels), θ is the angle of throwing the ball it's constant at 45° , $g = 9.8 \text{ m/s}^2$.

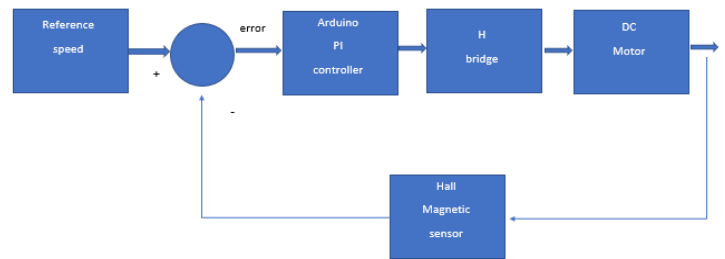

Fig2: Block Diagram for DC Motor Speed Control

Analysis of PI Controller:

In DC motor speed control, Proportional plus integral (PI) controllers are commonly used. Controller tuning techniques provide controller parameters as formulae or algorithms. They ensure that the control system obtained is stable and achieves the desired results. Direct current motor drives are used in a variety of speed and position control systems due to their excellent performance, ease of control, and high efficiency [9][10]. The error value is calculated by dividing a measured process variable by the set-point value. It then attempts to reduce the error by increasing or decreasing the process's control inputs, bringing the process variable closer to the set point [11].

From the ball position chosen the reference speed is calculated:

$$v_i^2 = \frac{R * 9.8}{\sin(2\theta)} \text{ (m/s)}$$

$$rpm_{ref} = v_i^2 * k$$

$k = 18/5$ to change to (klm/h).

The measured speed by hall magnetic sensor:

$$Rpm_m = (\max(1, \text{revolutions}) * 60000) / \text{elapsedTime}$$

When: $\text{elapsedTime} = \text{mills} - \text{start Time}$

$$\text{Error_speed} = rpm_{ref} - rpm_m$$

The error correction process ends when the output reaches the desired value

$$\text{Pwm-out} = \text{error_speed} * k_p + \text{error_speed_sum} * k_i$$

The gain constants of the pi controller (k_p ; k_i) are related to each other, as any increase in one of them can leave a significant difference in the value of the other.

3. SIMULATION and REALIZATION part:

The circuit was simulated on the proteus 8 professional platform, and we were able to read the results on the LCD screen (the output voltage and the PWM value, RPM) and we can get the response of the system and analyze it using the PI controller with the help of MATLAB (for tuning) according to the modeling scheme given in the following figure:

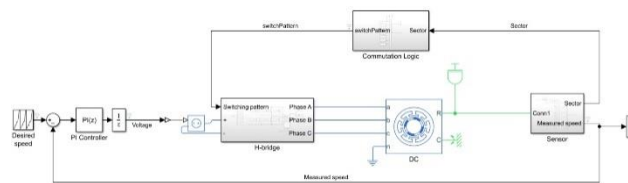

Fig 3: Simulation of the DC motor with controller

after tuning we fixed the $K_p=0.7$ and the $K_i=18$.

In the following figure, it shows the screen of the oscilloscope connected to the end of the circuit, which displays the output results of the system:

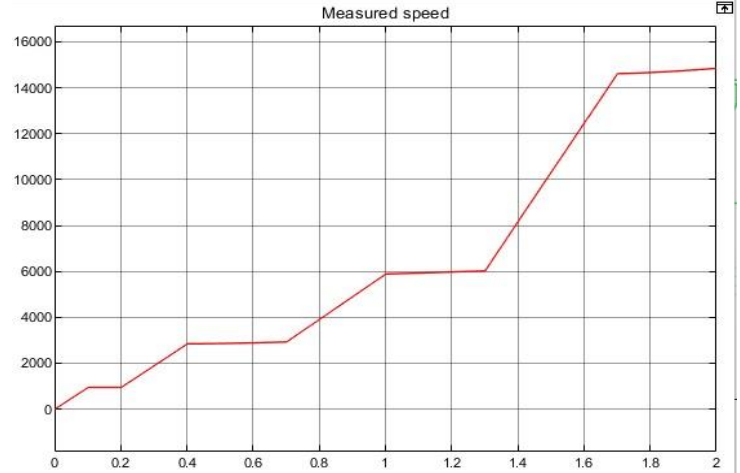

Fig 4: Output of the simulated DC motor with controller

here we tried to provide some steps input to the system when the speed of the DC motor reaches 1000 (rpm) and to 3000 (rpm) then 6000 (rpm) and to 15000 (rpm) in just a span of 2 seconds, this is exactly what is required. so, we conclude that the controller causes our motor to reach its preset value in a very short period of time.

Description:

The DC motors connected to the throwing wheels are the main element in the electrical circuit of this machine. If the speed of these motors is controlled, the speed and distance of the ball will be controlled to reach the desired position.

We connected the power supply with the H-bridge as an input and also the PWM signal emitted by the Arduino is inserted into the h-bridge for control the output voltage and we fixed the hall magnetic sensor near the magnet installed on the motor to measure Rpm_{meas} where when Rpm_{meas} changes an error signal is generated so through the pi algorithm The controller corrects the error signal generated by a team between Rpm_{meas} and Rpm_{ref} and the controller operates the output voltage from of the H-bridge so that this process continues as long as there is a difference between The two speeds.

Bluetooth is also connected to the Arduino via the Rx and Tx inputs to transmit and translate the voice signal emitted by the Android application.

In this article, I presented a complete H-Bridge DC motor driver built with four IR2807 MOSFETs. which is capable of handling currents of up to 80A, we used also in this PCB board Gate drivers and optocouplers for isolation and different capacitors and potentiometer, the following figure shows the final form of our PCB board.

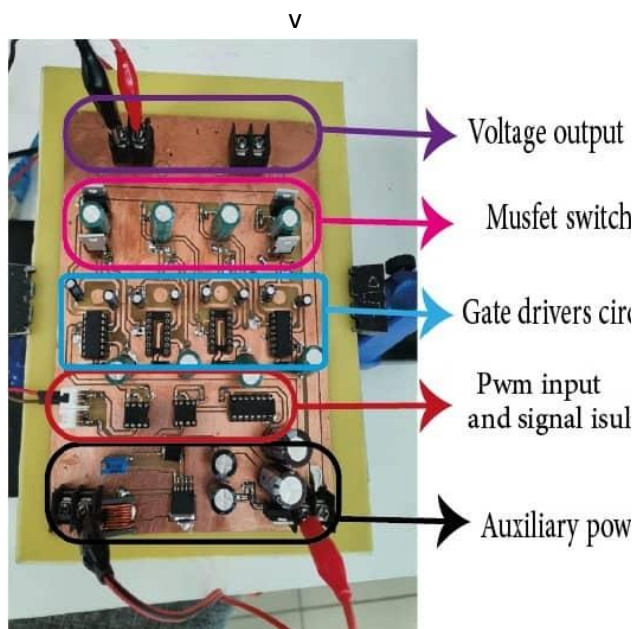

Fig5: the full H-bridge

In the following figure, this is our electrical circuit to control the DC motor of the machine in the presence of Arduino, h-bridge, and a smartphone to transmit audio and connect them with Bluetooth.

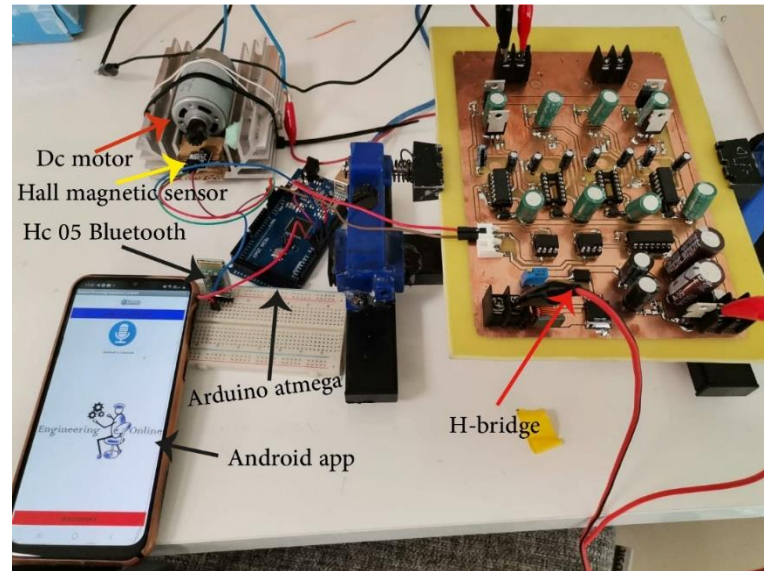

Fig6:the electrical circuit to control the dc motors of tennis throwing machine via voice control

The android application :

It is easy to create an Android application without the need to know the Java language, and this is by using the MIT app inverter website, where programmed speech can be recognized as data and transmitted as a signal to the Arduino connected to the Bluetooth. This application can be used in every Android device.

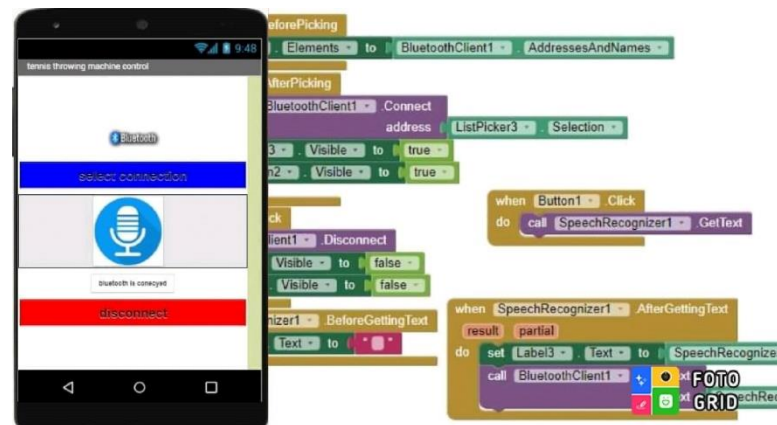

Fig7: The Android application for voice command

The results:

We have 9 shooting positions. Positions 1, 2, and 3 are in the same horizontal line from the second side of the playing field, 12 meters away from the machine. The difference is only in the throwing angle, where to move from the first position to the second position, a specific shooting angle is taken. When sending a voice as 1, 2, or 3, the reference speed is 11228.

The results can be seen on the serial monitor of the Arduino IDE. The following figure(fig8) shows the DC speed when sending the request 1, 2 or 3 (11228 rpm). In the following figure we see the difference between the reference speed and the actual response of the DC motor

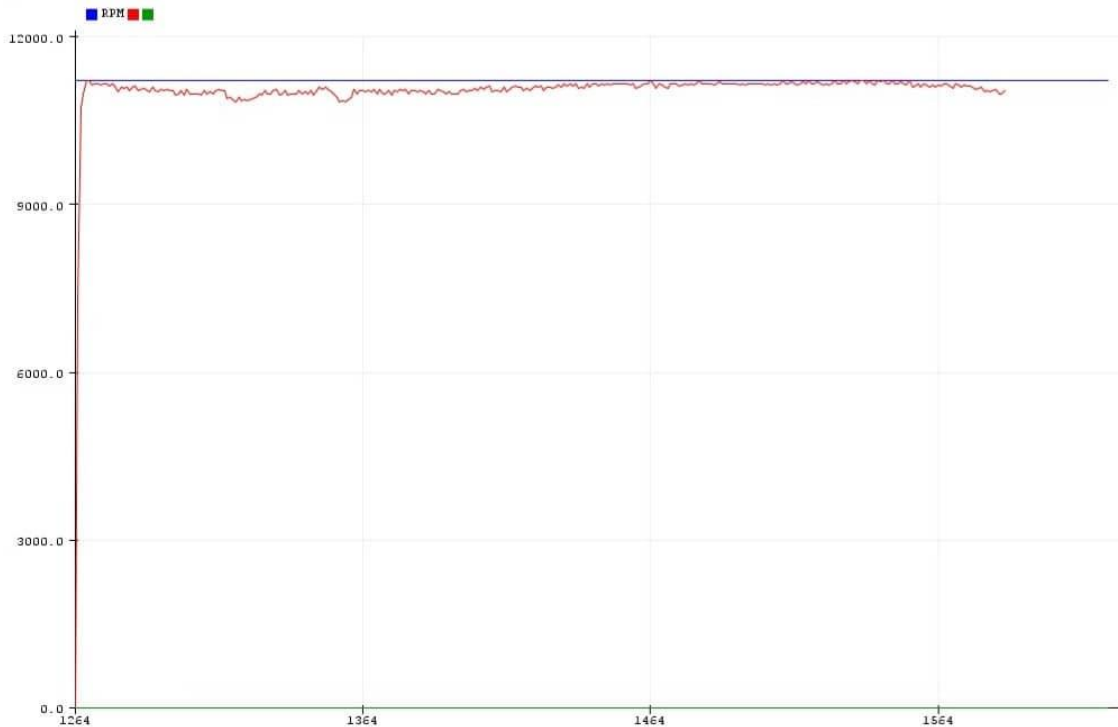

Fig 8: Motor response when sending command the number 1 or 2 or 3 (11228 rpm)

The same thing when sending a voice 4 5 6 The motors rotate at a specific speed calculated by the Arduino it can consider as a reference speed (11820 rpm) for throwing the ball at a distance of 13 m from the device, and the difference between these positions is only in the angle of throw, the result shows in figure 9.

To reach positions 7 8 9 the reference speed is the maximum speed of the DC motors (13000rpm) , we can see the result on figure 10.

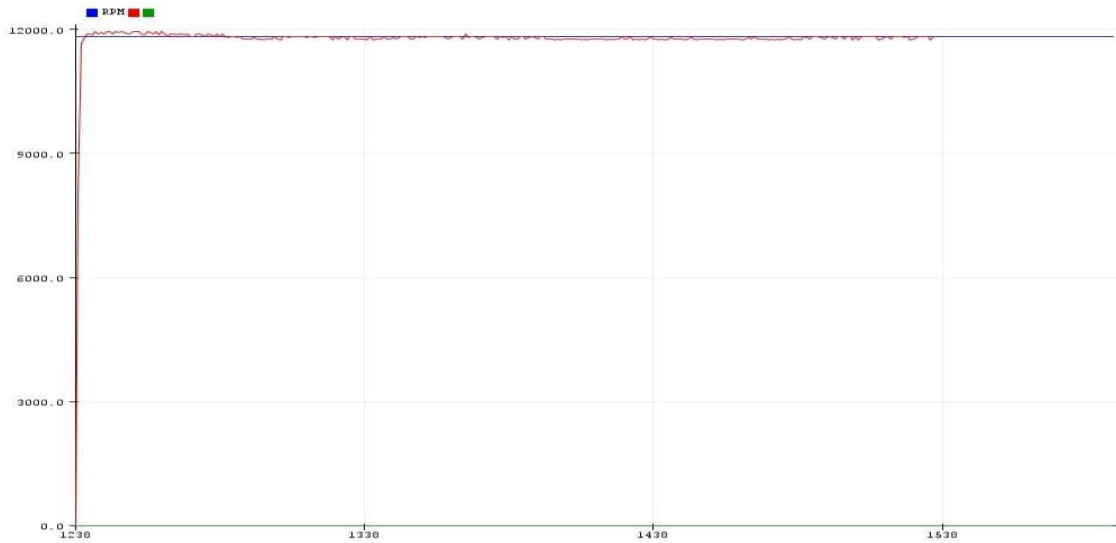

Fig 9: Motor response when sending command the number 4 or 5 or 6 (11820 rpm)

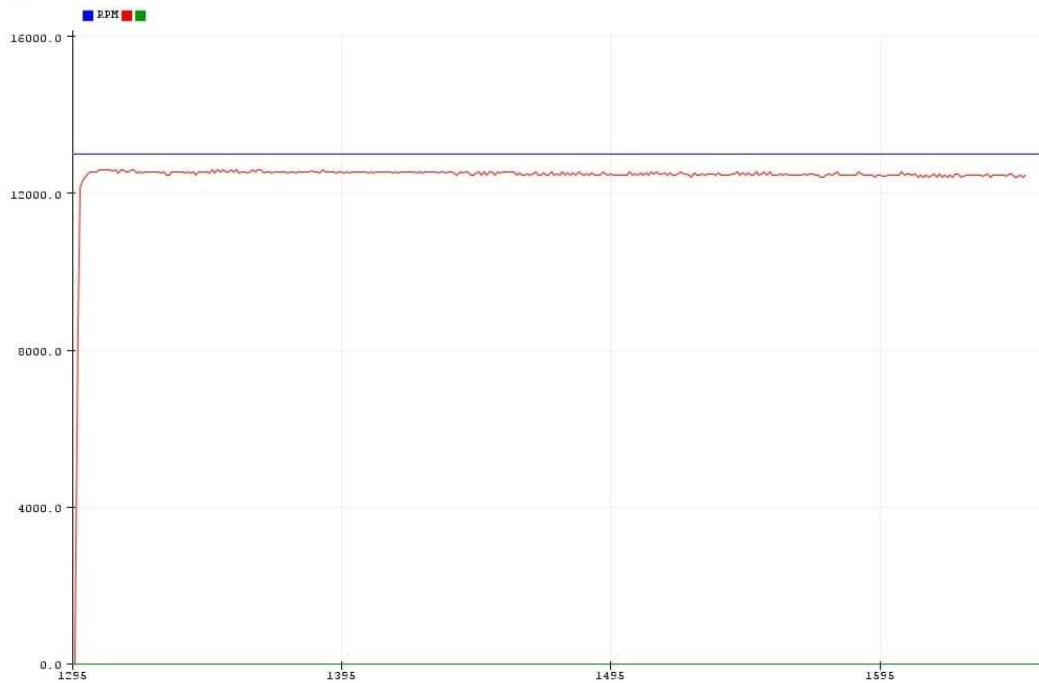

Fig 10: Motor response when sending command the number 7 or 8 or 9 (13000 rpm)

From the previous curves, we conclude that there is an actual response to the DC motor by the presence of a pi controller, so the value of k_p and k_i is suitable for adjusting the error between the reference speed and the actual speed.

4. Conclusion:

Through this work, players or those passionate about tennis sport will be able to raise the level of performance and training by adding the voice control technology so that the player can train without the need for a partner only by sending a voice message using the smartphone. The focus in this work was to control the speed of the existing DC motors in the machine, which in turn controls the speed and direction of the ball distance, depending on the pi controller, where the results were somewhat close to the required level.

References:

- [1] “DESIGN AND FABRICATION OF THROWER MECHANISM FOR TENNIS BALL MACHINE KHAIRUL AMZAR BIN MOHD KASSIM UNIVERSITI TEKNIKAL MALAYSIA MELAKA.”
- [2] J. Carboch, “Ball Machine Usage in Tennis: Movement Initiation and Swing Timing While Returning Balls from a Ball Machine and from a Real Server Tennis match analyses View project Squash match analysis View project,” 2014. [Online]. Available: <http://www.jssm.org>
- [3] “<https://www.erteo.com/blog/en/tennis-ball-machine/>”.
- [4] S. Perumalsamy, P. Ragupathi, and K. R. Rahul, “Design and Development of Volley Ball Practice Machine.”
- [5] C. Saal, J. Zinner, H. Fiedler, R. Lanwehr, and J. Krug, “Reliability and validity of a soccer passing test using the Footbonaut,” *German Journal of Exercise and Sport Research*, vol. 48, no. 3, pp. 334–340, Sep. 2018, doi: 10.1007/s12662-018-0511-6.
- [6] “6”.
- [7] “<https://howtomechanics.com/how-it-works/electrical-engineering/hall-effect-hall-effect-sensors-work/>”.
- [8] “Step 2: Code.”
- [9] N. Radmehr, H. Kharrati, and N. Bayati, “Optimized Design of Fractional-Order PID Controllers for Autonomous underwater vehicle Using Genetic Algorithm.”
- [10] C. ARSLAN, M. ARSLAN, G. YALÇIN, T. KAPLAN, and H. KAHRAMANLI, “Ball Throwing Machine Design To Develop Footballers’ Technical Attributes,” *European Mechanical Science*, vol. 5, no. 1, pp. 39–43, Mar. 2021, doi: 10.26701/ems.777400.
- [11] R. Toscano, “A simple robust PI/PID controller design via numerical optimization approach,” *Journal of Process Control*, vol. 15, no. 1, pp. 81–88, Feb. 2005, doi: 10.1016/j.jprocont.2004.03.005.