

Designing and Manufacturing a Single-Phase Transformer and Analyzing its Performance

ABSTRACT

Aims: This work aims to design a single-phase transformer for analyzing its performance based on some requirements.

Study design: At first, requirements are set, then the design was completed using AutoCAD, after that the designed machine was simulated in MATLAB Simulink, manufactured in real-time in the laboratory, tested experimentally, and then the equivalent circuit parameters were computed from the experimental data.

Place and Duration of Study: The design, manufacturing, simulation, and performance testing were conducted in the electrical machine 1 laboratory of American International University-Bangladesh (AIUB). It took around four months to complete the whole task.

Methodology: This work is a bit expensive and complicated process for students without any funds. So, a group was formed with eight students. The tasks were to design, simulate, implement, and test a single-phase transformer that would step down 220 V (ac) to 110 V (ac) having a 440 VA capacity, and core loss should not exceed 5 W.

Results: MATLAB Simulink was used to simulate the designed transformer to get the primary and secondary winding voltage and current wave shapes that were confirmed by the experimental results. Open and short circuit tests indicate that loss is only between 5 W and 8 W respectively. The total design cost is only BDTK1,270.

Conclusion: The results satisfied the design and performance parameter requirements and the designed transformer worked very well. **The design cost was also kept minimum.**

Keywords: Design, Implementation, Single-Phase Transformer, Performance Test.

1. INTRODUCTION

A transformer is an electrical machine that works on the principles of electromagnetic energy conversion. It is a kind of device that transfers electrical energy through the magnetic field from one electrical circuit to another keeping the supply frequency constant. The energy received from the supply mains is denoted as the primary side and the energy-distributing circuit to the load is denoted as the secondary side [1]. Transformers cannot create any energy but rather transfer energy by changing both the voltage and current levels of the circuit [2]. Transformers are commonly employed in electrical power generation and distribution sites for efficient transmission of electrical power to the grid network and then subsequent distribution to the end users [3]. There are many types and applications of transformers but all require efficient and low-loss transformers. But the efficiency of a transformer is reduced because of several types of losses in the transformer at no load and full load conditions [4-5]. Previously, a synchronous machine was designed for the electrical machine laboratory experiment [6]. So, the designed transformer can also be used for

laboratory demonstration purposes. This has motivated us to design a transformer with low loss and low cost so that after implementation, the loss is minimized and efficiency is maximized for any practical use. In this paper, we have explored to design of a low-loss small single-phase step-down transformer having a capacity of 0.44 kVA with a turns ratio of 2.

The main objectives of this paper are to-

- Design an energy-efficient single-phase transformer.
- Determine the equivalent circuit parameters of the designed transformer.
- Test the performance of the designed transformer.
- Find out the different performance parameters of a single-phase transformer.

2. LITERATURE REVIEW

In this section, we have reviewed some literary works to investigate our problems and other tasks to be performed by us after designing a single-phase step-down transformer. In one paper, we found the researchers to deal with the design, simulation, and implementation of a 0.3 kVA, single-phase, shell-type, tapped transformer. They performed the simulations using MATLAB and open and short-circuit tests to determine the efficiency of their designed electrical machine with the nearly agreeable simulation and experimental results [7].

Another paper is related to the development of a simulation model for the steady-state and transient responses of the distribution transformers through numerical methods considering the amorphous steel wound core. Their models are useful for analyzing the obtained responses in single-phase transformers. The authors claimed that their model is proficient enough to model any computer-aided design general and special types of single-phase transformers [8].

Another group of researchers investigated to design and manufacturing of a 1 MVA single-phase high-temperature superconducting (HTS) transformer with the rated voltage of primary and secondary as 22.9 kV and 6.6 kV, respectively using the BSCCO-2223 HTS tape for the HTS windings having concentric arrangements of coils in the HTS winding to reduce the AC losses. After that, they performed no load, short-circuit, and insulation tests at a very low liquid nitrogen temperature and thus validated their design [9].

In another paper, we found that the authors used the polarization and depolarization current (PDC) method, a kind of non-destructive method, to detect and analyze the insulation states of a high-voltage distribution transformer while engineering its fabrication. For this purpose, they designed and constructed a 22 kV, 30 kVA single-phase transformer. They used different insulating materials between iron core, low voltage (LV) and high voltage (HV) windings, etc. for testing purposes. They found that there is a relationship between the moisture content inside the paper insulation and the capacitance at line frequency [10].

One research group in their conference paper presented a numerical solver to use a 2D finite element method (FEM) to compute the flux distribution and core losses in a single-phase transformer with greater accuracy. It is capable of identifying the confined flux density and hot spots inside the core. They performed both experimental tests and numerical simulations for validating their numerical solver [11].

A research group described a novel method of constructing a stacked transformer core by employing united stacks of electrical steel to make the design tasks more simple and time-saving. They were also able to minimize the core losses by building three core designs, such as a conventional butt-lap core, a brick core, and a sub-core for a 50 kVA, single-phase, transformer core [12].

In an early-stage article, the authors described the design, manufacturing, and characteristics of a single-phase distribution-side power transformer using the oriented strip steel-based wound-type core based. Thus, they could reduce the core loss, excitation current, and noise level for the same design requirements [13].

In a very recent paper, the authors described a new modeling method for shell-type distribution transformers with diverse degrees of complexity. Their studies and evaluations on a 50kVA shell-type single-phase transformer showed the effectiveness of the finite element method to resolve the forces exerted on the coils. They investigated both 2-D and 3-D analyses [14].

Another research group published a paper on the design and practical prototype manufacturing of a single-phase transformer with 1 kVA power rating, 110/220 V voltage rating, and 60 Hz operating frequency based on an amorphous alloy core. They also tested the performance, compared their results with the published literature, and demonstrated to get a higher efficiency than that in the published paper [15].

3. MATERIALS AND METHODS

In this work, a core-type single-phase transformer was intended to be designed as shown in Fig. 1. The main specifications of the design of this transformer were to design a single-phase step down transformer with a turns ratio of 2 from an rms voltage of 220 V to 110 V (AC) with a maximum current flow of 2 A in the primary, that is 0.44 kVA. The operating frequency of the transformer should be in line with the power line frequency (50 Hz) of Bangladesh within the specified limits of 49.5-50.5 Hz (50 Hz \pm 1%) [16]. If the voltage is applied below this specified frequency level then the transformer's inductive reactance would be lower and more currents will be drawn by the transformer and thereby create more loss inside the transformer, and eventually, the temperature will rise. Besides, if the frequency is very high then the inductive reactance will be higher to cause more voltage drops across it and thereby reducing the magnetizing current of the transformer. As such, the transformer may not be able to produce required flux for its proper operation. The loss during the open circuit test must not exceed 5 W. For our practical design, we used super-enameled copper wires for the primary and secondary winding of our transformer. Multiple plates of sheets of iron silicon having E-shaped and I-shaped were used in this work. To provide isolation between the sheets and conductors, lamination papers were selected along with the masking tape. The required number of screws was used to join the sheets together. Brackets were used also in this work. Besides, a framework made of a wooden board was employed to place the transformer on it. To calculate the design parameters of a single-phase transformer, we need to follow several steps, like bobbin selection, core selection, turn/volt selection, and, conductor selection. We selected to have a magnetic flux density (B_m) of 1.2 Wb/m² because for designing a low-power transformer, this is the average value of magnetic flux density used by the designers. For the cross-section area of the transformer, we selected the length of the bobbin as $l = 3.7$ cm = 0.037m and the breadth of the bobbin as $b = 3.3$ cm = 0.033m due to its ready availability in the market. The cross-section was rectangular. As a result, the total cross-sectional area becomes $A = lb = 0.037 \times 0.033 = 0.001221$ m². Now we need to compute the number of turns for 1 volt as given by the equation (1).

$$T_e = \frac{1}{4.44 f B_m A} = \frac{1}{4.44 \times 50 \times 1.2 \times 0.001221} = 3.075 \quad (1)$$

Therefore, we can compute the number of turns required for the primary and secondary windings using equations (2) and (3).

$$N_p = T_e V_p = 3.075 \times 220 = 676 \quad (2)$$

$$N_s = T_e V_s = 3.075 \times 110 = 338 \quad (3)$$

Based on the number of turns, the required copper conductor for primary winding is 25 SWG and secondary winding is 21 SWG.

For the transformer design, the AutoCAD drawing software tool was used. After completion of the design, various views were observed to check how the designed transformer will look like. These are shown in various Figs. 1-4. Figure 1 shows a 3-D view of the designed transformer after the completion of the design along with the E-shaped and I-shaped cores in 2-D views on the right side. Figure 2 is the front view with the terminals for the line and neutral of the primary and secondary windings of the transformer. Figure 3 is the side view of the transformer showing how E- and I-shaped cores are inter-spaced inside the bobbins. Figure 4 shows the top view to show how the transformer is mounted on the base.

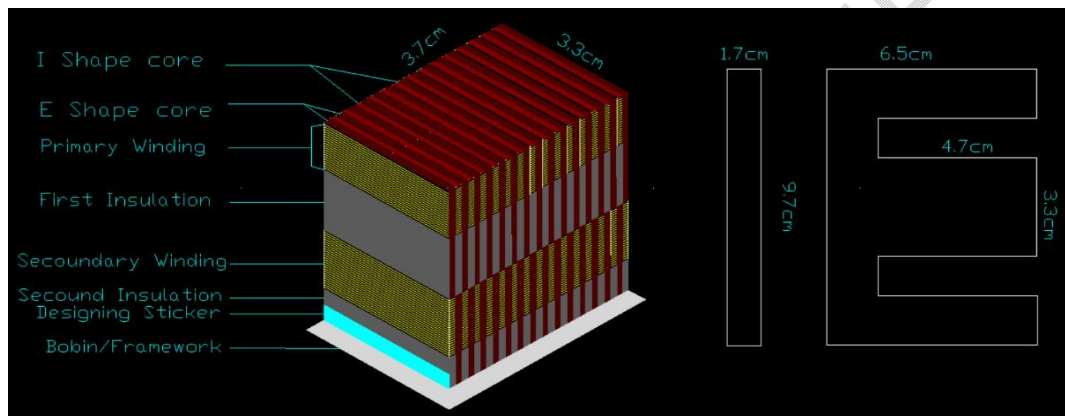

Fig. 1.A 3-D view and 2-D view of the transformer's core design in AutoCAD

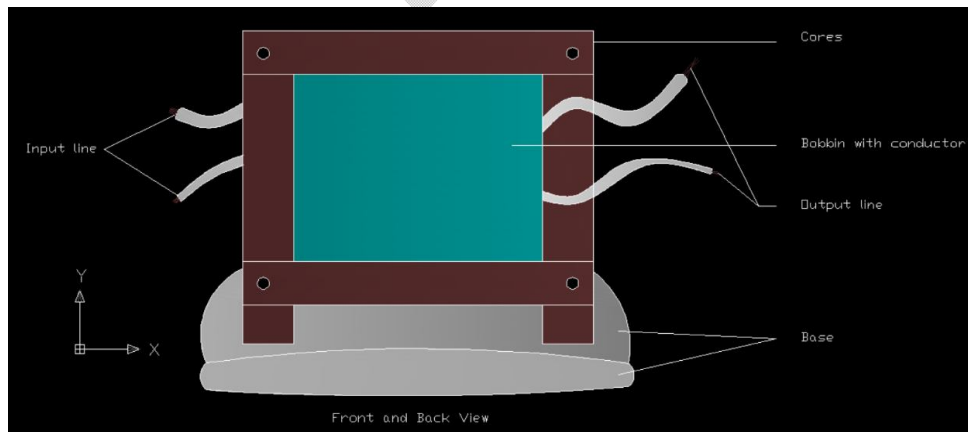

Fig.2.A 2-D view of the designed transformer with primary and secondary windings' terminals in AutoCAD

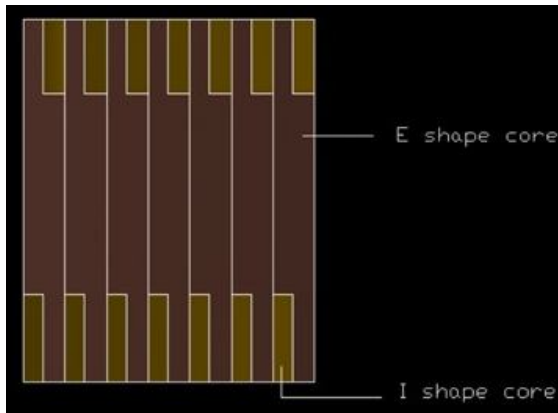

Fig.3.A 2-D side view of the designed transformer in AutoCAD showing the E-shaped and I-shaped cores

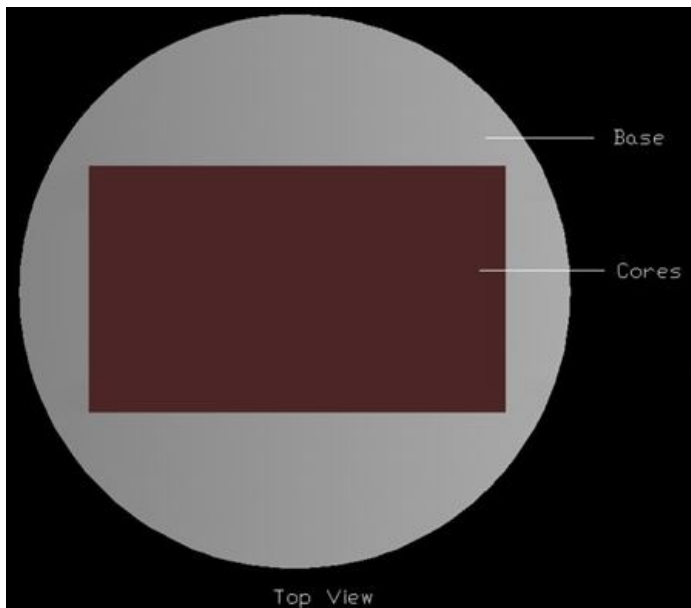

Fig.4.A 2-D top view of our transformer in AutoCAD shows the core on the base

After completing the calculations and AutoCAD design of the transformer, the following steps were followed to implement the design practically:

- At first, the primary winding was wrapped in the bobbin with the required 676 turns. Two output lines were created for the line and neutral wire of a single-phase transformer. On top of that, insulation papers were wrapped.
- After that, the secondary winding was wrapped and there were 338 turns. Like the primary winding, the secondary winding also has two output lines and paper insulation for the same purposes.
- Then the E-shaped core was fabricated very tightly and after that, the I-shaped cores were placed inside the blank spaces of the E-shaped cores.
- Finally, the completed transformer was mounted on cardboard for use.



Fig.5.Manufactured single-phase transformer on the base

4. SIMULATION AND EXPERIMENTAL RESULTS AND DISCUSSIONS

To simulate the single-phase transformer, MATLAB Simulink was used. At first, the circuit was drawn according to the design requirements. The ammeter and the voltmeter were connected in series and parallel, respectively. A load resistance (R) was also connected to the secondary side so that the secondary side draws current as shown in Fig. 6. Oscilloscope is connected to both the primary and secondary sides to observe the primary and secondary voltage and current levels. There are options for the rms current and voltage measurements, also.

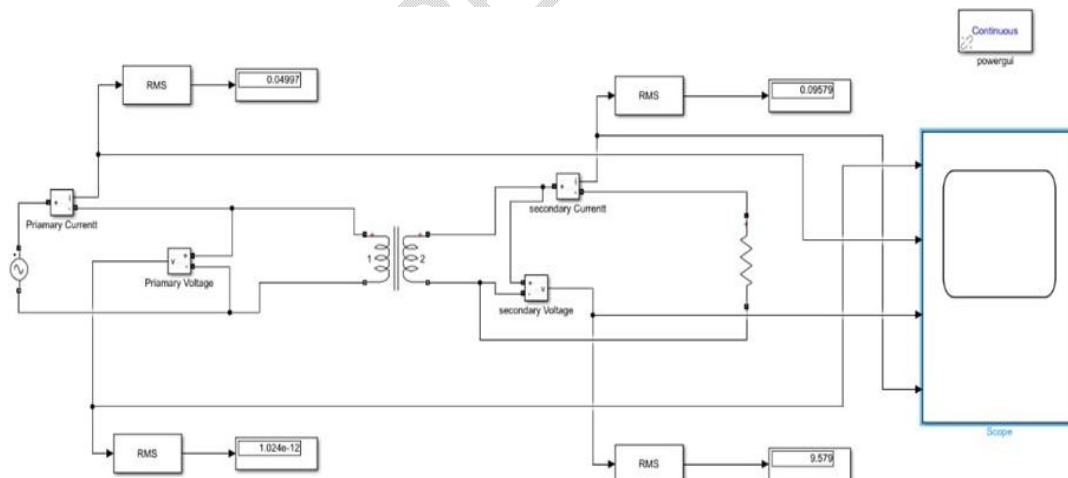

Fig.6.MATLAB Simulink diagram for the simulation of a single-phase transformer

After simulating the circuit, the results are obtained graphically and are shown in Fig. 7. The top left plot shows the primary voltage and the top right plot shows the secondary voltage of this transformer. From the simulation results, we see that upon application of the sinusoidal voltage of 220 V ac (peak) with a frequency of 50 Hz (the time period of 0.02 s) at the primary side, the secondary side produces the sinusoidal voltage of 110 V ac (peak) with the

same frequency as per our requirement. Moreover, the bottom left and right plots demonstrate the primary and secondary side sinusoidal currents, respectively. The results also show that as a current of 0.55 A (peak) with 50 Hz (the time period of 0.02 s) is passed through the primary coil the secondary steps it up to a level of 1.1 A (peak) with the same frequency.

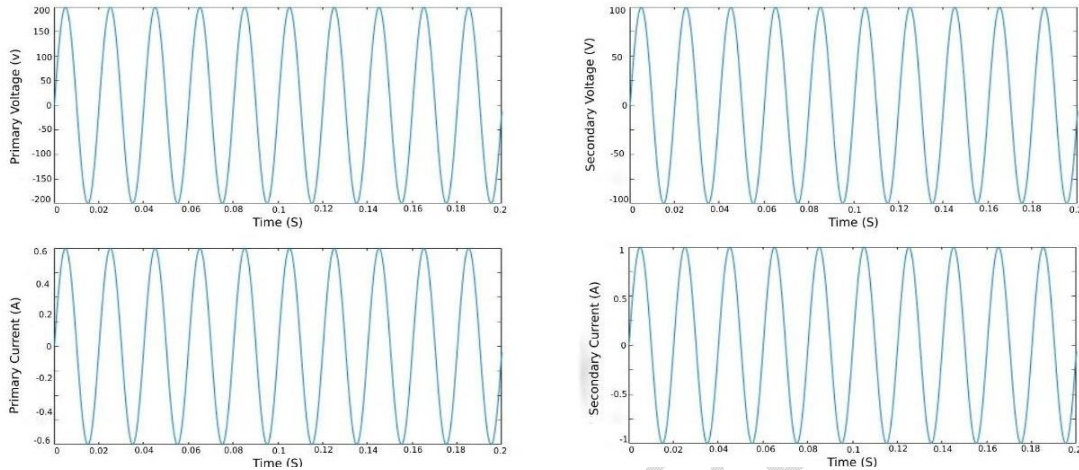

Fig.7. Primary and secondary voltage and current wave shapes after the MATLAB simulation with the necessary axis labels

A no-load test of the designed transformer was conducted to apply a small primary current (I_1) to the high-tension side of the transformer by applying a small voltage at the primary from AC voltage sources as shown in the experimental setup of Fig. 8. We applied the voltage from 0 V up to 350 V (AC) to check how much current can be flown to the primary winding without generating much heat in the transformer. We observed by touching the body of the transformer that it was getting heated and making humming sound when 350 V (AC) was applied. Then the secondary voltage (V_2) was measured at the low-tension side. We went to measure the secondary side voltage up to 176 V with the application of 350 V at the primary side to check that the turns ratio of 2 (approximately) is maintained. It means that the transformer core is still unsaturated. The observed data were recorded in Table 1 which confirms that the turn ratio of the transformer (primary to secondary) is almost 2 and remains constant always. From the data, a graph was plotted for the secondary voltage (LT-side) against the primary current (HT-side) as shown in Fig. 9. This graph shows that the secondary voltage starts to saturate after 180 mA. This satisfied our design requirement.



Fig.8. Practical setup for the performance test of the designed 1- ϕ transformer

Table 1. No load test of the designed single-phase transformer

Primary Voltage, V_1 (V)	Primary Current, I_1 (mA)	Secondary Voltage, V_2 (V)
50	9	24
100	14	49
150	20	74
200	30	99
250	46	124
300	110	149
350	190	176

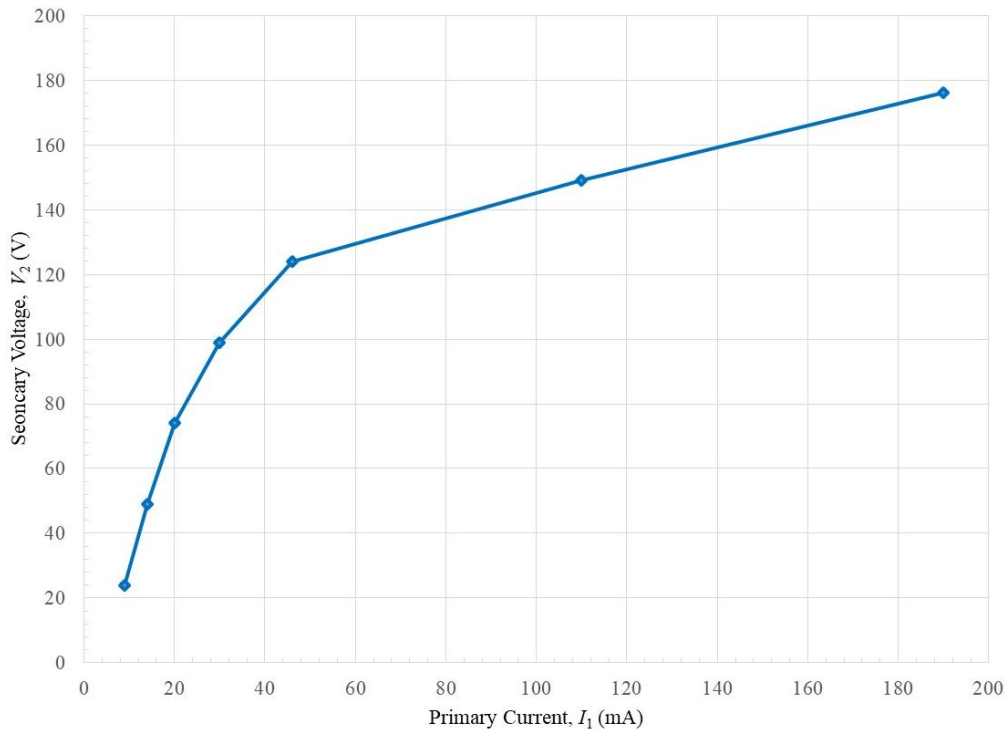

Fig.9.Secondary voltage vs. primary current from the practical measurements

We performed several tests with the designed transformer. For example, the polarity test, open circuit test, short circuit test, and load test. From the polarity test, we found that the transformer was of additive polarity.

To perform the open circuit test, we connected the rated supply voltage at the low-tension side and measured the voltage, current, and power loss at that side and also measured the open circuit voltage at the high-tension side. As such, an ammeter, voltmeter, and wattmeter were connected on the low-tension side and only a voltmeter on the high-tension side.

To perform the short circuit test, we connected a low supply voltage at the high-tension side and increased it until a rated current flows through the primary side with the secondary (low-tension) side shorted. We measured the voltage, current, and power loss at that side and also measured the short circuit current at the low-tension side. All the data of both measurements are shown in Table 2. Besides, the average voltage regulation with a full load was 1.82% at the secondary side and the average efficiency was 85.7% with output connected to the secondary side of the transformer.

Table 2. Open circuit and short circuit test results

Corresponding Parameters at the supply voltage side	Open Circuit Test Data	Short Circuit Test Data
Power (W)	5	40
Voltage (V)	110	60
Current (mA)	112	1000

After that, we computed the equivalent circuit parameters of our designed single-phase transformer and provide them in Table 3.

Table 3. Open circuit and short circuit test results

Equivalent Circuit Parameters	Values in Ohm
Core loss resistance (as referred to the HT side), R_0 (Ω)	9,680
Magnetizing reactance (as referred to the HT side), X_0 (Ω)	3,962
Copper loss resistance (as referred to the LT side), R_1 (Ω)	40
Copper loss resistance (as referred to the HT side), R_1' (Ω)	160
Core reactance (as referred to the LT side), X_1 (Ω)	44.72
Core reactance (as referred to the HT side), X_1' (Ω)	179

We have also analyzed the cost. In total, we needed only BDTK1,270 (Bangladeshi taka one thousand two hundred and seventy only). This is equivalent to US\$12.5 (US Dollar twelve point five only) [17]. The final cost breakdown is shown in Table 4. In an article published in 2015, we found that the material cost of design of a single-phase transformer (having ratings of 230V/115V, 50 Hz, 5 kVA, and a voltage regulation at full load of 2.3%) was INR8,056 (Indian Rupees of eight thousand and fifty six only) [18].

Table 4. Open circuit and short circuit test results

Equipment Name	Price (BDTK)
Iron core materials (E and I type) (2 kg)	400
Lamination Paper	20
Copper Wire (400 gm)	500
Framework (Bobbin)	50
Wooden board	100
Miscellaneous	200
Total	1270

5. CONCLUSION

A single-phase transformer is required for various applications, such as in charging the batteries for UPS/IPS, in low-voltage lighting circuits, in small-scaled home appliances, etc. Our designed transformer met the specified requirements. The short circuit current and open circuit voltage were measured that met the design requirements. In addition, the required amount of primary equivalent resistance and reactance were obtained through experimental tests. The power loss, efficiency, voltage regulation, and voltage step-down requirements were also satisfied. Besides, the simulation confirmed the practical measurements. In the future, we want to design the power transformer, current transformer, and potential transformer for some other applications. Besides, we need to test the transformer for a wide range of applications.

REFERENCES

1. Chapman SJ, Electrical Machinery Fundamentals. 5th ed. McGraw Hill; February 2011.

2. Mehta VK, Mehta R. Principles of Electrical Machines. 3rd ed. Sultan Chand; December 2006.
3. Kosow IL, Electric Machinery and Transformers. 2nd ed. Pearson College; January 1991.
4. Sanusi YA, Ohadugha CB, Martins VI, Olaide SA. Energy Resources of Southern Africa: Potentials and Sustainable Energy Delivery. Journal of Energy Research and Reviews. 2022;12(2): 1-13.
5. Gill P. Electrical Power Equipment Maintenance and Testing. CRC Press, Taylor & Francis Group, 2009.
6. Bhuyan MH, Das D, Islam R. Design and Manufacturing of a Low Cost Synchronous Motor-Generator for Electrical Machine Laboratory. Proceedings of the Conference on Engineering Research, Innovation and Education (CERIE), Shahjalal University of Science and Technology (SUST), Sylhet, Bangladesh, 11-13 January 2011, 525-529.
7. Aziz MS, Saleem U, Ahmed S, Ali M. Simulation, design and fabrication of an efficient single phase transformer. IEEE Power Generation System and Renewable Energy Technologies (PGSRET), 2015, 1-5, DOI: 10.1109/PGSRET.2015.7312233.
8. Stulov A, Tikhonov A, Dryazgov D. The Combined Model for Design Single-Phase Transformer with Amorphous Steel Wound Core. IEEE International Conference on Industrial Engineering, Applications and Manufacturing (ICIEAM), 2020, 1-6, DOI: 10.1109/ICIEAM48468.2020.9111942.
9. Kim S-H, Kim W-S, Choi K-D, Joo H-G, Hong G-W, Han J-H, et. al. Characteristic tests of a 1 MVA single phase HTS transformer with concentrically arranged windings. IEEE Transactions on Applied Superconductivity, 2005;15(2):2214-2217. doi: 10.1109/TASC.2005.849615.
10. Nganpitak T, Nimsanong P, Maneerot S, Pattanadech N. Dielectric Response Analysis of Mineral Oil Immersed Transformer Insulation during Manufacturing Process. IEEE 20th International Conference on Dielectric Liquids (ICDL). 2019, 1-4. DOI: 10.1109/ICDL.2019.8796642.
11. Abbaszadeh K, Gholamian SA, Ardebili M, Toliyat HA. Modeling of B-H Loop for Core Loss Calculations in Power Transformer Using Finite Element Method. 12th Biennial IEEE Conference on Electromagnetic Field Computation, 2006, 289-289. DOI: 10.1109/CEFC-06.2006.1633079.
12. Marketos P, Meydan T. Novel Transformer Core Design Using Consolidated Stacks of Electrical Steel. IEEE International Magnetics Conference (INTERMAG), 2006, 127-127. DOI: 10.1109/INTMAG.2006.375627.
13. Gordy TD, Somerville GG. Single-Phase Power Transformer Formed Cores. Transactions of the American Institute of Electrical Engineers. 1950;69(2):1384-1387. DOI: 10.1109/T-AIEE.1950.5060308.
14. Salon S, LaMattina B, Sivasubramaniam K. Comparison of assumptions in computation of short circuit forces in transformers. IEEE Transactions on Magnetics. 2000;(36:5):3521-3523. DOI: 10.1109/20.908881.

15. Luciano BA, de Morais ME, Kiminami CS. Single Phase 1-kVA Amorphous Core Transformer: Design, Experimental Tests, and Performance After Annealing. IEEE Transactions on Magnetics. 1999;(35:4):2152-2154. DOI: 10.1109/20.774186.

16. Electricity Grid Code, 2019, Bangladesh Energy Regulatory Commission, Bangladesh, Web link: <https://berc.portal.gov.bd>, accessed on 21 October 2022.

17. <https://www.xe.com/currencyconverter/convert/?Amount=1270&From=BDT&To=USD>, accessed on 15 October 2022.

18. Basak R, Das A, Sanya A. Cost Optimal Design of a Single-Phase Dry Power Transformer. Indonesian Journal of Electrical Engineering and Informatics (IJEEI), 2015;(3:4):261-266. DOI: 10.11591/ijeei.v3i4.206.

UNDER PEER REVIEW