

ORIGINAL RESEARCH ARTICLE

INFLUENCE OF NUMBER OF FLATLOCALLY-FABRICATED TURBINE BLADESON THE PERFORMANCE OF A SIMPLIFIED PICO HYDROPOWER SYSTEM

Abstract

Five locally fabricated turbines with 3, 5, 7, 9 and 11 flat blades were locally fabricated and tested in conjunction with a vertical penstock of diameter 0.0762m and nozzles of diameters 0.0158, 0.0212, 0.0266, 0.0343 and 0.042 m in a simplified Pico hydropower system. **This study is an aspect of an ongoing work aimed at ultimately implementing the system for small power generation.** The turbines were mounted at the foot of an overhead reservoir 6.95 m high. A 1.11 kW pump was used to recycle the water downstream of the turbine from an underground reservoir to the overhead reservoir, and a 3.9 kVA alternator used for the on-load tests. The turbine was linked to a 3.9 kVA alternator by a belt drive of pulley ratio of 6:1. The mean rotational speeds of each turbine and alternator shafts, volume of water displaced, and voltage developed were measured for each nozzle diameter. These data were used to compute flow rate, shaft and electrical power, and efficiency for each operation. Dimensionless flow, head and power coefficients as well as specific speed were computed and functional characteristic curves relating plotted. The turbine with 11 blades developed the maximum voltage with the nozzle diameter of 0.042 m and the least voltage for 0.0158 m diameter nozzle. The corresponding estimated power output computed using the manufacturer's specifications on the alternator was also highest and the mean maximum efficiency based on the estimated power output was 0.4482. This indicates that the larger nozzle diameters combined with the turbine with higher number of flat blades favour beneficial system operation. The results indicate good potential for the system as a simple, environmentally friendly and decentralized small power generation system that can contribute to the current energy mix in Nigeria.

Keywords: Decentralized, Energy crisis, Environmentally friendly, locally-fabricated turbine, Nozzle diameter, Number of flat blades, Pico hydropower.

INTRODUCTION

Globally, energy demand is increasing, leading to the need for the generation of energy from renewable resources. Africa is still grappling with the great challenge of access to clean energy services because energy is fundamental for socioeconomic development and poverty eradication [1-4]. Energy plays a critical role in the economic growth, progress, and development, as well as poverty eradication and security of any nation, with the per capita energy consumption directly affecting the living standard [5-10]. Future economic growth will be affected by availability of energy from sources that are affordable, accessible, sustainable and environmentally friendly. The world is gripped with an energy crisis largely due to rapid population growth and increase in the living standard of whole societies [11, 12]. In Nigeria, industrial and commercial activities have been paralyzed by it, and leading to the incidence of poverty [13, 14]. Around 84% of Nigeria generating capacity is thermal (Gas turbine), with the remaining 16% hydroelectric and steam turbine respectively [15, 16]. The private sector has also produced an additional 90 MW from an installed capacity of 270 MW and an additional 30 MW from Emergency Power Plant at Abuja (EPP).

In Nigeria, clean, sustainable, reliable and affordable energy has always been a subject of great interest especially because a large percentage of the Nigerian population lives without access to energy which has led to technological backwardness as investors shy away from the country due to high cost of production. About 40% Nigerian households have access to the national grid while more than 45% do not, with much more than 6% supporting their grid access with personal petrol/diesel generators and around 3% relying completely on self-generator [17]. About 1.1% have access to the rural electrification programs and nearly 75% of Nigerians still depend on firewood as their cooking fuel with about 20% relying on kerosene. This is directly as a result of the low access to electricity and its low reliability of services. An urgent need for efforts for further developments of the overall Nigerian electricity sector as well as rural electrification programs to ensure rapid economic development therefore exists [13, 18-21]. The energy revolution will require moving from electricity systems based on centralized large-scale fossil fuels,

large hydro and nuclear fission plants to the ones based on new renewable sources and massive improvements in the efficiency of production, transportation, and storage and use energy [22-24].

Renewable energy alternatives are an important part of future energy, and need to be promoted and enabled. But renewable energies can also negatively impact on the environment and people, therefore the need for impact assessment tools to be applied to such projects. These sources such as small hydro, modern biomass, wind, solar, geothermal, and bio-fuels now account for a higher percentage of global final energy consumption and are growing rapidly, hence replacing conventional fuels [25-28]. Hydropower is a renewable, economic, non-polluting and environmentally benign source of energy, and amongst all renewable sources of energy it is the most reliable and cost effective accounting for a reasonable percentage of global electricity production from both large and small power plants second only to fossil fuels [29-33]. The world has endless potential for hydropower generation. Numerous numbers of hydropower stations have been built all over the world and a large number of hydro power projects with a capacity above 100, 000 MW currently going on globally with Asia having the largest contribution of 84, 000 MW.

In Nigeria, a very minimal part of the available 14750 MW power is currently being explored at Kainji, Jebba and Shiroro hydropower stations [18, 19, 34-36]. This implies that the percentage of the nation's hydropower potential in use is quite small. The country has consistently experienced epileptic power supply partly as a result of its inability to exploit its vast hydropower potential in addition to the fact that the available large hydro power plants are not operating up to installed capacity [16, 37-40]. Presently, the government of Nigeria is making efforts to improve and stabilize the power sector including advanced work at Kashimbilla (around 40 MW expected soon according to government sources) and Gurara.

However, large hydropower schemes are generally affected by seasonal fluctuations in water level apart from adversely affecting marine ecology as well as the social well-being of people [41-47]. To combat the problem of seasonal variation in water level as well as other issues with conventional hydropower systems, pumped storage have been developed which involves storing water at a higher level and releasing it to generate power by turning a turbine at a lower level. Small hydro schemes have gained popularity especially in rural communities due to its simplicity in design, ease of operation, low environmental impacts in comparison to large hydropower schemes. Furthermore, communities could take advantage of simple drinking water projects or irrigation systems to install small hydro schemes. Generally, developing ways of utilizing the advantages of hydropower which minimize the operational and natural shortcomings is a step in the right direction [48-56].

Pico-hydro power (up to 5 kW) provides a very good option, suiting the general characteristics of smarter, smaller systems which can be utilized in locations where larger more conventional systems cannot be optimally deployed. They are more efficient and environmentally friendly, with various benefits such as reliability, simplicity, less maintenance and low operating expenses. It can easily be controlled and maintained by homes, schools, farms and communities [14, 57-62]. Conventional Pico hydro systems are run-of-stream, meaning a reservoir of water is not created, only a small weir is common, pipes divert some of the flow, drop down a gradient and through the turbine before being exhausted back to the stream. The Pico hydro systems are significant in our world today because power generation through this means cuts down fossil fuel consumption thereby reducing pollution [63-65]. They however, have some technical and social challenges. Flooding easily sweep machinery away and the acceptance of this technology is not straightforward as is to be expected. Plus the fact that in Nigeria, like many other developing societies, the political will to drive its intensive uptake is lacking [66, 67]. This study is part of an ongoing development of a Pico hydropower system as a contribution to the mitigation of the energy crisis in Nigeria especially in locations without naturally flowing water.

Theoretical Background

The power input in to a hydraulic turbine is given by the equation 1 [68].

$$P_h = \rho g Q H_n \quad (1)$$

Where ρ = water density, g = acceleration due to gravity, Q = flow rate, and H_n = net head defined as shown in equation 2 [69].

$$H_n = H_g - H_L \quad (2)$$

Where H_g is the gross head and H_L is the sum of all head losses in the penstock. The Head loss is made up of the major and minor losses caused by viscous forces in the pipe and secondary flow structures resulting from changes in direction and geometry of the flow, respectively. The major losses, H_f can be found using equation 3 [69].

$$H_f = \frac{6.87L}{d^{1.165}} \times \left[\frac{V}{C} \right]^{1.85} \quad (3)$$

Where V is the flow velocity, d pipe diameter, L pipe length and C the Hazen-Williams coefficient (between 135 and 140 for plastic pipes and 150 for steel pipes). The mean velocity of the water in a pipe (or jet) is given by $V = Q/A$, where A is the cross sectional area of the flow [70, 71].

The minor losses is defined as shown in equation 4. The contraction loss coefficient for pipe shape geometry is found using equation 5 and sum of all the head losses given by equation 6 [69, 71, 72].

$$H_{minor} = \frac{V^2}{2g} \sum K_l \quad (4)$$

$$K_c = 0.42 \left[1 - \left(\frac{d}{D} \right)^2 \right] \quad (5)$$

$$H_L = H_f + H_{minor} + K_C \quad (6)$$

The loss coefficients for various common fittings have been determined experimentally and K_c is dependent on the ratio of pipe diameters d/D , where d is internal diameter of the small pipe and D internal diameter of the large pipe. The contraction normally occurs at the end of the pipe or penstock before entry into the turbine in the form of nozzle/reducer to convert the water into a jet [68, 71].

The efficiency of the turbine is given by equation 7 [73, 74].

$$\eta = \frac{\text{Power output from shaft}}{\text{hydraulic power input}} = \frac{P_s}{P} \quad (7)$$

The power output or shaft power is given by equation 8 [39, 75].

$$P_s = \rho Q (V_1 + V_2) \frac{2\pi DN}{60} \quad (8)$$

where V_1 and V_2 are the velocities of water through the pipe and nozzle respectively, N = rotational speed.

The flow (K_Q), head (K_H) and power (K_P) coefficients as well as specific speed (K_S) can be computed using the equations 9 to 11 [68, 76].

$$\text{Flow coefficient, } K_Q = \frac{Q}{ND^3} \quad (9)$$

$$\text{Head coefficient, } K_H = \frac{gH}{N^2 D^2} \quad (10)$$

$$\text{Power coefficient, } K_P = \frac{P}{\rho N^3 D^5} \quad (11)$$

where D = turbine runner diameter.

Another parameter which can be used to compare turbines is the specific speed defined in equation 12.

$$\text{Specific speed, } N_s = \frac{K_P^{1/2}}{K_H^{5/4}} \quad (12)$$

where N_s is the specific speed, N rotational speed of the runner in rpm, P the turbine power output in kW, and H_n the net head in meter. The term specific speed arises from the idea of a given type of machine producing a unit power at a unit head, and is the speed at which it would run. Specific speed is then neither dimensionless (specific) nor a speed. It is better regarded as a "shape factor" and it is its ability to describe the shape of a turbine design independently of turbine size [77].

Previous aspects of work on the System

Edeojaet *al.* [14] reviewed on the suitability of Pico hydropower deployment in Nigeria in view of the energy supply situation and the potential benefits available especially for the teeming rural populace. The consistent power outages resulting from the vast distribution networks frequently subjected to sabotage was identified as a strong motivation for adopting such a power supply system in which the end users will have more direct control. They however opined regrettably that there was a strong absence of the political will necessary to facilitate its uptake. Edeojaet *al.* [71] carried out a conceptual design of a simple decentralized self-powering Pico hydropower system which uses the basic principle of a pumped storage hydro system as an alternative to contribute to the mitigation energy crisis in developing communities. The unique features of the system include a vertical penstock linking an overhead reservoir and a locally fabricated turbine as well as a water recycling loop using a pump to facilitate the application of the system where there is no naturally flowing water. The system models smaller, smarter, decentralized systems which are less expensive, more environmentally benign and concede the control to the end user thereby reducing the exposure to influence of outsiders especially with the proliferation of insurgent activities in Nigeria.

An investigation of the effect of penstock configuration with regards to area reduction on the performance of the simplified Pico hydropower system was carried out. The system explored the utilization of the head developed by pumping water into an overhead reservoir and discharging it through a vertically oriented penstock. The concept area reduction was introduced in order to extend the duration of continuous recycling of the water while minimizing head losses and achieving higher power output. The penstock configurations were obtained by reducing pipes of diameters 76.2 m to 50.8 m in ratios of 5:2, 4:3, 3:4, 2:5 and 1:6 over a total height of 6.8 m. The configuration with the ratio of 5:2 produced the highest rotational speed and voltage, suggesting that the use of a penstock configuration with a larger diameter forming the greater part of the total head will favor better power generation while ensuring sustained continuous water recycling [78].

Edeoja *et al.* [79] examined the effect of blade cross section on the performance of the system. Blades of various cross-sections (rectangular, trapezoidal, u-shaped, partial v-shaped, and full v-shaped) were fabricated for the turbine and the optimum turbine performance using each of the specified blades determined. The results obtained indicated that the full v-shaped blade gave the best performance in terms of rotational speed, and consequently voltage and power output. Edeoja and Awuniji [80] studied the effects of penstock configuration and lateral twist angle of flat blades on the performance of the simplified Pico hydropower system. Two configurations of the penstock having 2 and 1 stages of area reductions were used in conjunction with locally fabricated turbine runners with flat blades laterally twisted at 30, 45, 60, 75 and 90°. The results showed that the turbine with the 90° blade twist gave the best performance in terms of rotational speed and consequently power for both penstock configurations.

A study of the basic operational parameters of the simplified Pico hydropower system was carried out using five simplified versions of the Pelton turbine of runner diameters 0.45, 0.40, 0.35, 0.30 and 0.25 m, along with five PVC pipes of diameters 0.0762, 0.0635, 0.0508, 0.0445 and 0.0381 m as penstocks and five simple nozzles of area ratios 1.0, 0.8, 0.6, 0.4 and 0.2. The results showed that for all the turbine and penstock diameters, the nozzle area ratios in the range 0.2 to 0.6 performed better in terms of system power and efficiency. They noted that small nozzle area ratios combined with correspondingly larger penstock diameters are necessary for optimum operation of the system. The results obtained highlighted the relevance of proper nozzle selection in the system operation [81].

Edeoja *et al.* [82] studied the effects of penstock area reduction and number of turbine v-blades on the performance of the simplified Pico hydropower system. One and two stage area reductions from 3 to 2½ inches, and then from 3 to 2½ to 2 inches were effected on the penstock, and turbine runners with 6 to 12 v-blades were tested for each configuration. The results obtained indicated that the two stage area reductions of the penstock with the runners having 9 -10 blades produced the highest shaft rotational speeds as well as computed fluid power. They observed that the possibility exists of further stages of penstock area reduction to improve the system performance with no advantage for system performance at that state for number of blades lower than 9 to 10.

An investigation of the influence of penstock outlet and runner hub to blade ratio on the performance of the simplified Pico hydropower system was conducted. Five turbine runners with 10 v-shaped blades and hub to blade ratios of 0.7, 0.65, 0.55, 0.4, and 0.3 were fabricated and tested. The results obtained showed that the system with 0.55 runner hub to blade ratio and 20 mm penstock outlet diameter yielded an alternator shaft speed of 1732 rpm corresponding to a computed power output of 5.77 kW. In terms of the loss of the alternator speed compared to the ideal value, the hub to blade ratio of 0.55 also gave the least percentage loss with the corresponding penstock outlet diameter being 25 mm [40].

Edeoja *et al.* [83] investigated the effect of the included angle of v- blades on the simplified Pico hydropower system. Five turbine runners having 6 v-shaped blades with included angles of 30, 60, 90, 120 and 150° were fabricated and tested on system. A maximum speed of 1810 rpm and a corresponding voltage of 224 V were obtained with 30° included angle which decreased progressively to 1750 rpm and 218 V for 150°. These results suggested that for optimum performance of the system, smaller included blade angles for the configuration used translating to deeper blades are necessary. They opined that further reduction of the included angle beyond this range will require much smaller water jets however, concluding that the observation will be useful in the further development of this system for use in buildings and small workstations in isolated locations with water reservoirs.

The influence of penstock outlet and the flat blade lateral twist angle on the performance of the Pico-hydro system was undertaken. Five penstocks reduced from 76.2 mm to 15, 17.5, 20, 22.5 and 25 mm diameters at the outlet and a runner with adjustable flat blades were fabricated, and for each of the penstock outlets, five blade twist angles of 50, 55, 60, 75 and 90° were tested. A maximum computed power of 5600 W was obtained with the 25 mm penstock outlet in conjunction with the blade twist angle of 75°. Also, the maximum speed of 1180 rpm of the alternator shaft was obtained for a penstock outlet diameter of about 20.25 mm at the same twist angle of 75°. They observed that the system could generate appreciable power using flat blades with the penstock outlets and blade twist angles in the

ranges > 20 mm and $\geq 60^\circ$ respectively, and that considering the simplicity of the flat blade configuration, the results indicate good promise for providing relatively cheap, clean and convenient domestic power[84].

Edeoja and Tarka[85] studied the effect of penstock diameter on shaft power of the simplified Pico hydropower system with water recycling. The mean efficiencies were 0.776 and 0.510 for penstocks diameters 0.0762 and 0.0381 m respectively. They concluded that larger penstock diameters with small nozzle area ratios favor optimal system operation. Edeoja and Tarka[75] studied the basic operational parameters of the simplified Pico-hydropower system by measuring the mean maximum and minimum rotational speeds of the shaft of each turbine for each penstock diameter and nozzle area ratio. The plots of the shaft power against the flow rate/net head product for each pair of turbine and penstock diameters resembled the analytical expression for hydraulic power. They concluded that the results obtained formed a useful contribution to the process of developing the system as a simple, environmentally friendly and decentralized small power generation system that could contribute positively to the Nigerian energy mix.

Edeoja *et al.* [76] investigated the basic operational parameters of the simplified Pico hydropower system, using five simplified locally fabricated turbine of runner diameters 0.45, 0.40, 0.35, 0.30 and 0.25 m, five PVC pipes of diameters 0.0762, 0.0635, 0.0508, 0.0445 and 0.0381 m as penstocks and five simple nozzles of area ratios 1.0, 0.8, 0.6, 0.4 and 0.2 for each penstock diameter. They computed dimensionless coefficients as a standard procedure generally used for comparing geometrically similar hydraulic machines and concluded that the results will be invaluable in development of the system into a simple, environmentally friendly and decentralized small power generation system that could contribute positively to the energy mix in Nigeria.

The basic influence of runner diameter on the operation of the Pico hydropower system with provision for water recycling were investigated by Edeoja *et al.* [86]. Five highly simplified versions of the Pelton turbine of runner diameters 0.45, 0.40, 0.35, 0.30 and 0.25 m were locally fabricated and tested in conjunction with PVC pipes of diameters 0.0762, 0.0635, 0.0508, 0.0445 and 0.0381 m as penstocks and simple tapered pipes with area ratios 1.0, 0.8, 0.6, 0.4 and 0.2 fabricated based on each penstock diameter as nozzles. The mean efficiencies based on the runner diameters were in the range $0.656 \geq \eta \geq 0.642$. They concluded that the results fundamentally indicated that the influence of the runner diameter in the range used on the optimum performance of the system was not pronounced like that of the other parameters and that the possibility of scaling up the turbine diameter to accommodate larger penstock diameters and a higher capacity alternators exists as a target of future development.

Edeoja *et al.* [39] carried out on-load tests based on the results of no-load tests carried out on the simplified Pico hydropower system in order to investigate the estimated power output. A turbine of runner diameter 0.40 m, penstock diameters in the range 0.0381 m to 0.0508 m and nozzle area ratios in the range 0.2 to 0.6 were used for the on-load tests. The system developed a maximum voltage of 224 V with the penstock diameter of 0.0508 m and a minimum voltage of 111 V with that of 0.0381 m both with nozzle area ratio of 0.6. The corresponding estimated power outputs were 2.125 kW and 1.545 kW respectively, with corresponding mean maximum and minimum efficiencies based on the estimated power output of 0.85 and 0.618. The results indicated good promise for the system's implementation.

Edeoja *et al.* [38] considered the influence of penstock outlet, number of v-blades, flat blade lateral twist angle and hub to blade ratio on the performance of the simplified Pico hydropower system. This multi parameters investigation was undertaken in order to provide several options for selection in implementation for end user applications. The results of the study have heightened the enthusiasm and confidence of the research team in this regard.

The general summary of the results so far indicate a good potential for deployment with the issue still being tackled revolving around the water recycling aspect. The unique feature of this effort is recycling the water to enable the application of the system where naturally flowing water is not available. The pump saddled with this aspect is still powered externally, meaning that the system could be successfully deployed using a hybrid scheme with solar energy to power the pump. This of course will increase the cost significantly. However, the initial goal of developing a standalone system has not changed and this is the background leading to the current investigations.

MATERIALS AND METHODS

This investigation was carried out in the Department of Mechanical Engineering at Joseph Sarwuan Tarka University (formerly Federal University of Agriculture), Makurdi. Mild steel was used for the entire turbine wheel construction due to its good weldability, machinability, ductility and toughness in addition to the availability of the material at an affordable cost compared to other metals. The runner for this study is highly simplified, resembling a Kaplan runner. It is made up of a circular hub welded to two circular supports of diameter equal to that of the turbine wheel such that hub to blade ratio is 0.55 [38, 40]. Holes of diameter 20 mm are drilled on the circular supports to accommodate the shaft which is appropriately secured to the supports. The radius of the cover is 20cm wide in order to accommodate the largest penstock diameter used in previous aspects of the study which is 76.2 mm and to facilitate

welding operations during the fabrication. The blades were made up of flat strips of the sheet metal of about 10cm width were then appropriately welded around the periphery of the hub and unto the inner faces of the circular support. The diameters of the runners as well as the circular hub to blade ratio were taken from Edeojaet *al.*[71] as with the previous studies. The hub and blades were fabricated from a 2 mm thick mild steel sheet. Five runners were fabricated with 3, 5, 7, 9 and 11 flat blades and they are shown in Figure 1.

A support made of 2 × 2 mm angle iron was provided for the turbine at the foot of the stanchion directly beneath the penstock. The support is firmly held in place with concrete with adequate clearance to allow the free rotation of the turbine wheel. Adequate provision was made to channel the water back to the underground reservoir and a fitting protective cover was used to prevent water splashing during the operation of the system and to serve as a guide for the nozzles. Two bearings matching the shaft diameter are provided at the ends of the support on which the turbine runner is mounted. Figure 2 shows a CAD produced exploded view of the set up without the reservoirs and the piping.



Fig.1.The Turbine Runners used for the study

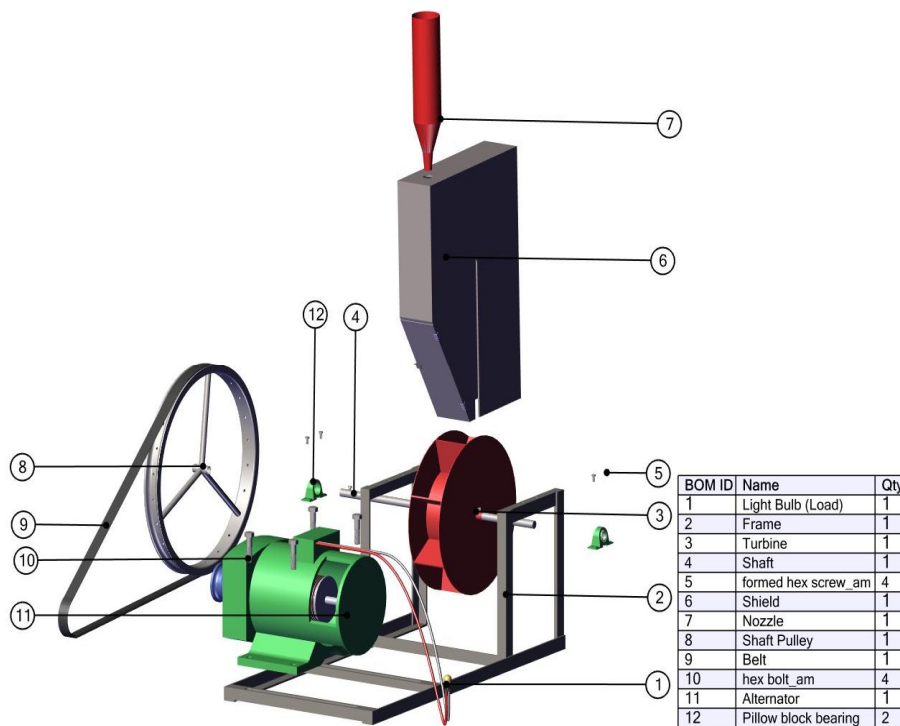

Fig. 2. Exploded View of the Turbine Assembly

The experimental set up for this study consists of a pump and the turbine connected with PVC piping as penstock to a 2000 liters overhead tank and a 3000 liters underground reservoir. A drain allows the water downstream of the turbine to be returned into the underground reservoir. Care was taken to align the turbine runner and the nozzle so as to ensure adequate clearance between the runner, penstock and nozzle. The turbine was coupled to a 3.9 kVA alternator via a belt pulley drive of ratio about 1:6 provided by a 600 mm diameter pulley is connected to the turbine

shaft and a 50 mm diameter pulley connected at the alternator for the on-load tests. Figure 3 shows the full experimental set up.

Water is released from the overhead tank through the penstock and it flows through the nozzle to the turbine. The flow through the turbine is regulated using a gate valve installed before entry to the penstock. The water jet striking the runner produces a torque resulting in the rotation of the turbine shaft and then the alternator shaft for the on-load tests. The suction pipe of the pump delivers water from the underground reservoir to the overhead tank to create a head.

The main variables monitored in this study were the rotational speeds of the turbine and alternator shafts, the depths of water in the overhead and underground reservoirs before and after each operation, the time taken for each operation and the voltage developed by the alternator and/or the current. The data was used to compute the gross head available, the head losses, the net head available, the flow rate and the power generated as well as efficiency using the appropriate equations from the theoretical background section. The water depths were monitored using calibrated dip sticks and a tape while a stop clock was used for timing each operation. A tachometer was used to measure the rotational speeds of the shafts while a multimeter was used to measure the electrical quantities. The procedure was repeated for each of the turbine runners. All the data were then plotted and also conveniently analyzed for variance at 95% confidence level.

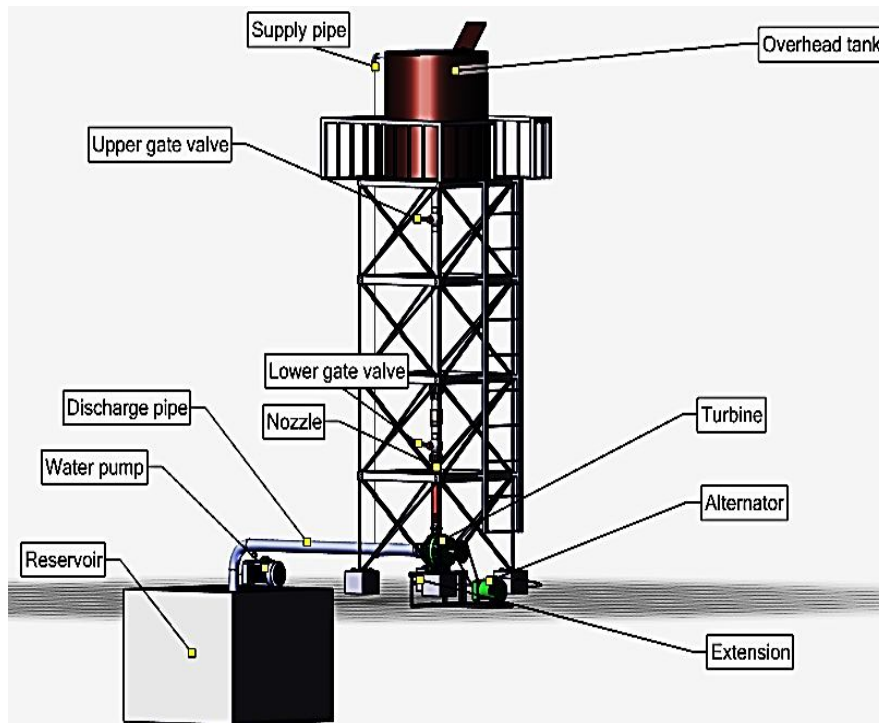

Fig. 3. The whole Experimental set up.

RESULTS AND DISCUSSION

Figure 4 shows the variation of head loss with nozzle diameter for the different number of blades of the turbine for no-load (a) and on-load (b) tests respectively. Both figures show that the head loss increased with an increase in nozzle diameter in accordance with basic fluid mechanics principles and that the number of blades expectedly did not affect the head loss. This underscores the need to properly select nozzle diameters to enhance the maintenance of a favourable head which is critical for beneficial hydropower operation [87, 88].

Fig. 4. Variation of Head Loss with Nozzle Diameter for the Number of Flat Blades for (a) No-load, and (b) On-load tests.

Figure 5 shows the variation of net head (difference between the gross head and head loss) with flow rate for the different turbines for the no-load (a) and on-load (b) tests. Generally, the net head decreased with increasing flow rate as a consequence of the observations explained in Figures 4(a) and (b), since increased flow rate is enhanced by increased nozzle diameter. The clustering of the trendlines indicate that the number of turbine blades do not affect the flow rate, this slight dispersion especially with the case for no-load being most likely a pointer to the fact that the flow rate is within a particular range for the system. The relationships show how these basic parameters required for conventional hydropower site selection can be used in selecting appropriate sizes of the required components [89, 90].

Fig. 5. Variation of Net Head with Flow Rate for the Number of Flat Blades for (a) No-load and (b) On-load tests

Figure 6 shows the variation of turbine speed with the number of flat blades for the nozzle diameters used for the study. The Figure shows that the speed increases with the increase in the number blades, and then tends towards a constant value beyond 7 blades for both no-load and on-load conditions. This underscores the requirement of a higher number of blades to a particular range after which the benefit erodes in line with earlier findings with this system and others [91, 92]. As the number of blades increase, a necessary trade-off between the weight and required speed becomes necessary for a specified level of operation [86, 88]. The speed values for the no-load tests were obviously higher than those for the on-load tests and the observation is not far-fetched since the loading condition had changed. The apparently errant trend for the 0.0212 m diameter nozzle in Figure 6(b) could be due to slight errors associated with measurements. However, the trend for the same nozzle diameter for the no-load tests in Figure 6(a) shows that the delivery of the water jet was in harmony with those for the remaining nozzle diameters. Figure 6(b) also shows that the larger nozzle diameters enhanced higher turbine speeds primarily due to the fact that they delivered higher flow rates in line with basic mechanics of fluids [62, 77].

Fig. 6. Variation of Turbine Speed with Number of Flat Blades for the Nozzle diameters for (a) No-load and (b) On-load tests.

The variation of the no-load turbine speed was highly significant at 0.05 level along the rows (nozzle diameters) and less slightly significant along the columns (number of flat blades). This statistically confirms that both parameters affected the torque developed to cause the turbine rotation as expected because the nozzle diameters dictate the flow rate while the number of blades determines how much blade surface area is available for interaction with the water jet [77, 88]. The on-load turbine speed varied differently at the same level with the 2 parameters. While affirming the contribution of both of them, it varied more significantly with the number of blades than with the nozzle diameters. This indicates the different loading situation of the turbine with the use of the belt drive to link the turbine with the generator. Under this condition, the surface area of blades become more critical in the torque production process [58, 93].

Figure 7 shows the variation of the generator speed with the nozzle diameter for the different number of turbine blades. The rotational speed of the alternator generally increased with an increase in nozzle diameter this is because an increase in nozzle diameter leads to an increase in the flow rate which consequently leads to an increase in the rate of change of momentum of the turbine and by extension the alternator rotational speed [73, 74]. The Figure also shows that the higher numbers of the blades enhanced higher speeds of the generator due to the larger surface area available for interaction with the water jet. Figure 8 shows the variation of the generator speed with the number of flat blades for the respective nozzle diameters for the on-load tests. They generator speeds generally mirror the variation with the turbine speeds as they are their multiples due to the amplification brought about by the use of the belt drive in line with the generator manufacturer's specification for speed in order to generate power. For this work as earlier stated, the drive ratio was 6:1. Matching the turbine and generator speeds in Figures 6(b) and 8 show that the belt drive used for this study was able to achieve the desired objective to a large extent.

Fig. 7. Variation of Generator Speed with Nozzle Diameter for the Number of Flat Blades for the On-load tests.

Fig. 8. Variation of Generator Speed with Number of Flat Blades for the Nozzle diameters for the On-load tests.

Fig. 9. Variation of Shaft Power with Nozzle Diameter for the Number of Flat Blades for the On-load tests.

The variation of the on-load generator speed at the same level with the nozzle diameters and number of flat blades mirrors the one for the on-load turbine speed. This is obviously as a result of the fact that the generator speed is a multiple of the corresponding turbine speed, and this was achieved by the installation of belt drive with a theoretical pulley diameter ratio of 6:1 [72, 94]. This statistically confirms the achievement of a level success with the belt drive use.

Figure 9 shows the variation of shaft power with nozzle diameter for the different number of turbine blades for the on-load tests. The shaft power increases with an increase in nozzle diameter and was highest in the turbine with 11 blades with a value of about 2100 W. This is because this parameter depends on the turbine speeds developed. Generally, the higher number of blades precipitated higher values of shaft power [95, 96].

The inherent requirement for a larger diameter in order to deliver higher flow rates for power production is suggested in Figure 10 in which the 2 larger nozzle diameters clearly enhanced the higher shaft power values with the others enhancing values below 200 W. This strengthens the need to properly select the water delivery outlet diameters to enhance acceptable system performances for any given situation [75, 97]. The Figure also portrays relationship between the shaft power and increasing number of blades, with the steepness of the trendlines more pronounced for the higher nozzle diameters again indicating the benefit of larger diameters over the smaller ones [27, 88].

The on-load shaft power varied highly significantly with the nozzle diameters at 0.05 level but the variation was barely significant with the number of flat blades. This is expected because the computation of the shaft power was largely dependent on the hydraulic attributes of the system and not on the kinetic properties of the turbine [59, 98]. This explains why the variation with the number of blades was negligibly significant.

Fig. 10. Variation of Shaft Power with Number of Flat Blades for the Nozzle diameters for the On-load tests.

Figure 11 shows the variation of the electrical power with the generator speed for the different number of turbine blades for the on-load. The electrical power increased with an increase in the generator speed and was highest in the turbine with 11 blades with a value of 950 W. This was because the increase in the number of blades lead to an increase in the weight of the turbine and consequently an increase in momentum of the turbine. The greater the momentum, the greater the generator speed and hence the higher the electrical power generated [99, 100].

Fig. 11. Variation of Electrical Power with the Alternator Revolution for the different Number of Flat Blades for the On-load tests.

Figure 12 shows the Variation of Electrical Power with the Nozzle Diameter for the different number of blades of Flat Turbine on-load. The electrical power increased with an increase in nozzle diameter and was highest in the turbine with 11 blades with a value of 950 W. This was because the increase in the nozzle diameter led to an increase in momentum of the turbine. The greater the momentum, the higher the alternator rotational speed and hence the higher the electrical power generated [74, 101].

Figure 13 shows the variation of electrical power with number of blades for the various nozzle diameters. The Figure also indicates that the larger diameters enhanced higher power production but the trends are now less linear than those in Figure 10 for the shaft power values. This could be partly explained by the fact that factors like the electrical characteristics of the generator also critically affect the output [102]. The trendlines also indicate the possibility of higher power generation with slight further increase in the number of blades, the steepness affirming the fact already mentioned that the increase in the number of blades may not necessarily be continuous as this will cause the erosion of the benefit in terms of power production.

The electrical power varied slightly significantly with the nozzle diameters and less so with the number of flat blades. This can only be explained by the fact that the contribution of nozzle diameter and number of blades is not as prominent as those of other factors such as the electrical characteristics of the generator. This underscores the need of proper selection of the component for optimal output when implementing a power supply system [103, 104].

Fig. 12. Variation of Electrical Power with the Nozzle Diameter for the Number of Flat Turbine Blades for the On-load tests.

Fig. 13. Variation of Electrical Power with Number of Flat Blades for the Nozzle diameters for the On-load tests.

Figure 14 shows the Variation of Efficiency with Nozzle Diameter for the different Number of Flat Turbine on-load. The efficiency increase with an increase in nozzle diameter and was highest in the turbine with 11 blades with a value of 0.45. This was because an increase in the nozzle diameter leads to an increase in the weight of the turbine and hence the alternator rotational speed. This leads to an increase in the electrical power and hence efficiency [61, 105].

Fig. 14. Variation of Efficiency with Nozzle Diameter for the Number of Flat Blades for the On-load tests.

Figure 15 shows that the system efficiency generally increased with the number of flat blades for the respective nozzle diameters used for the study and that the larger diameters enhanced the efficiency of operation [90, 91]. However, the values were also not overtly dispersed showing that the system, for all the nozzle diameters, had all the efficiency values within a narrow range, indicating some level of consistency with the fabrication of all the turbines and nozzles [60, 72]. It is also noteworthy that the trendlines for all the nozzle diameters with the exception of the 0.0266 m show better controlled operations probably because that nozzle diameter indicated a turning point between the larger and smaller diameters.

The system on-load efficiency varied highly significantly with the nozzle diameters and less so with the number of flat blades at the 0.05 level. This means that statistically, the nozzle diameters and number of blades have a reasonable contribution to the system efficiency among the other system parameters. The nozzle diameters do

however dominate which is expected because in conventional hydropower practice in the main parameters that determine the choice of site [61, 68].

Fig. 15. Variation of Efficiency with Number of Flat Blades for the Nozzle diameters for the On-load tests.

Figure 16 shows the variations of the head coefficient and the power coefficient with the flow coefficient for the different number of turbine blades for the no-load tests. These coefficients are standard procedure for comparing geometrically similar components and are invaluable in choosing component sizes for future implementation of the system [51, 76]. The head coefficient increased marginally with an increase in flow coefficient after an initial decrease as shown in Figure 16(a). This is because as the flow rate increases, the net head reduces as earlier mentioned. Figure 16(b) shows the variation of the power coefficient with flow coefficient for the different number of turbine blades. The power coefficient increased smoothly with increase in flow coefficient and there was hardly any relationship with the number of turbine blades. However, since the flow coefficient involves basically the flow rate, the power coefficient mirrors virtually the same value (or close values) for every value of the flow coefficient as the flow rate increases with the shaft power as pointed out earlier [72, 74].

Fig. 16. Variation of (a) Head Coefficient with Flow Coefficient, and (b) Power Coefficient with Flow Coefficient for the Number of Flat Blades for the No-load tests.

CONCLUSION

The results from this study strongly strengthens the need to properly match large nozzle diameters with number of turbine blades **greater than 7** in order to obtain beneficial power yield from the system. This is underscored by the performance of the system with a 0.042m nozzle diameter with 11 blade runners. **The results further indicate the potentials of the system for implementation for domestic and small scale power requirements in rural locations especially where naturally flowing water is not available.** Further work on some aspects of the system has been planned in order to upgrade it to self-running status.

References

- [1] Lajqi, S., Bresa, Q., Bresa, A., Doçi, I. and Đurin, B. (2021). Design, Implementation and Analysis of the Overall Performance of a Micro Hydro Turgo Turbine, Journal of Thermal Engineering (Yildiz Technical University Press, Istanbul, Turkey), 7(4): 806-822.
- [2] British Petroleum (2017). BP Energy Outlook 2017 Edition. Available at www.bp.com/energyoutlook#BPstats, 9-22, 74-77, 90-94.

- [3] Bala, E.J. (2013a). Renewable Energy and Energy Efficiency Development in Nigeria, Keynote Paper at the 2-day Workshop on Renewable Energy and Energy Efficiency, 10th – 11th June, 2013, NnamdiAzikiwe University, Awka.
- [4] Sinagra, M., Picone, C., Picone, P., Aricò, C., Tucciarelli, T. and Ramos, H.M. (2022). Low-Head Hydropower for Energy Recovery in Wastewater Systems. *Water* 2022, 14, 1649. <https://doi.org/10.3390/w14101649>.
- [5] CPPA (2015). Towards Achieving Sustainable Development for all: Prioritizing Targets for Implementation: Which way forward for Nigeria? Available from: www.cpparesearch.org/wp-content/.../Country-profile-on-SDGs-Nigeria-Final-Version.pdf
- [6] Bergasse, E., Paczynski, W., Dabrowski, M. and Dewulf, L. (2013). The Relationship between Energy and Socio-Economic Development in the Southern and Eastern Mediterranean, MEDPRO Technical Report No. 27/February 2013. https://www.ceps.eu/system/files/MEDPRO%20TR27_CASE%20Bergasse_%20Energy%20and%20Socio-economic%20Development_updated_15Feb2013.pdf
- [7] Saatci, M. and Dumrul, Y. (2013). The Relationship between Energy Consumption and Economic Growth: Evidence from a Structural Break Analysis for Turkey, *International Journal of Energy Economics and Policy*, 3(1): 20-29.
- [8] Pirlogea, C. and Cicea, C. (2012). Econometric perspective of the energy consumption and economic growth relation in European Union. *Renewable and Sustainable Energy Reviews*, 16: 5718–5726. [Doi.org/10.1016/j.rser.2012.06.010](https://doi.org/10.1016/j.rser.2012.06.010).
- [9] Kirubi, C., Jacobson, A., Kammen, D. M. and Mills, A. (2009). Community-Based Electric Micro-Grids Can Contribute to Rural Development: Evidence from Kenya, *World Development*, 37(7): 1208 – 1221.
- [10] Nfah, E.M., Ngundam, J.M., Vandenbergh, M. and Schmid, J. (2008). Simulation of off-grid generation options for remote villages in Cameroon, *Renewable Energy*, 33: 1064 – 1072.
- [11] International Energy Agency (IEA) (2015). World Energy Outlook. Available online at www.iea.org/t&e/, 1 – 12.
- [12] British Petroleum (2016). BP Energy Outlook 2016 Edition: Outlook to 2035. Available at www.bp.com/energyoutlook#BPstats, 44, 74-77, 90-94.
- [13] Awosope, C. A. (2014). Nigeria Electricity Industry: Issues, Challenges and Solutions, Covenant University Public Lecture Series. 3(2): 5-15.
- [14] Edeoja, A. O., Ibrahim, S. J. and Kucha, E. I. (2015a). Suitability of Pico-Hydropower Technology for Addressing the Nigerian Energy Crisis – A Review, *International Journal of Engineering Inventions*, 4(9).
- [15] IRENA (2021). Nigeria Energy Profile. Published by International Renewable Energy Agency, pp. 2. Available at www.irena.org
- [16] Fagbohun, O. O. (2016). Studies on Small Hydro-Power Potentials of Itapaji Dam in Ekiti State, Nigeria. *International Journal of Engineering Science Invention*, 5(1): 28-36.
- [17] Oseni, M. O. (2012). Households' Access to Electricity and Energy Consumption Pattern in Nigeria, *Renewable and Sustainable Energy Reviews*, 16: 990 – 995.
- [18] Adejumbi I.A., Adebisi O.I., Oyejide S.A. (2013). Developing Small Hydropower Potentials for Rural Electrification, *IJRRAS*, 17(1): 105 – 110.
- [19] Bala, E.J. (2013). Renewable Energy and Energy Efficiency Development in Nigeria, Keynote Paper at the 2-day Workshop on Renewable Energy and Energy Efficiency, 10th – 11th June, 2013, NnamdiAzikiwe University, Awka.
- [20] Gujba, H., Mulugetta, Y. and Azapagic, A. (2011). Power generation scenarios for Nigeria: An environmental and cost assessment, *Energy Policy*, 39: 968–980.
- [21] Omede, J. and Omede, A. A. (2015). Poor and Inadequate Electrical Power Generation, Transmission and Distribution in Nigeria: Economic, Psycho-Social, Health, Security and Educational Consequences, *Journal of Applied Science*, 1(7): 1 – 11.
- [22] Lajqi, S., Lajqi, N., Hamidi, B. (2016). Design and Construction of Mini Hydropower Plant with Propeller Turbine, *International Journal of Contemporary Energy*, 2(1): 1-13.
- [23] Othman, M.M., Razak, A.J., Basar, M., Muhammad, N., Wan Mohammad, W., Sopian, K. (2015). A Review of the Pico-Hydro Turbine: Studies on the Propeller Hydro Type, *International Review of Mechanical Engineering*, 9(6): 527-535. <https://doi.org/10.15866/ireme.v9i6.5876>
- [24] WHO (2015). Health in 2015: From Millenium Development Goals (MDGs) to Sustainable Development Goals (SDGs), 3-11. Available at www.who.int

- [25] Efurumibe, E.L., Asiegbu, A.D. and Onuu, M.U. (2014). Renewable energy and prospects in Nigeria, *Scholarly Journal of Scientific Research and Essay (SJSRE)*, 3(6): 73 – 76.
- [26] Selim, F. F., Abdelaziz, A. and Taha, I.B.M. (2021). Economic Design of Hybrid Pico-Hydraulic/Photovoltaic Generation System: A Case Study in Egypt, *Electronics*, 10, 2947. <https://doi.org/10.3390/electronics10232947>.
- [27] Khomsah, A., Sudjito, Wijono, and Laksono, A. S. (2019). Pico-Hydro as a Renewable Energy: Local Natural Resources and Equipment Availability in Efforts to Generate Electricity, 1st International Conference on Advanced Engineering and Technology, IOP Conf. Series: Materials Science and Engineering, 462(2019) 012047.
- [28] Diswe, J. N., Dudas, K. A. C., Padilla, A. J. A., Roca, R. R. A., Isla (Jr.), I. F. and Gumasing, M. J. J.(2020).Installation of Pico-Hydro System to Augment the Electricity Requirement of a Rural Community in Victoria Oriental Mindoro, Philippines, Proceedings of the 2nd African International Conference on Industrial Engineering and Operations Management Harare, Zimbabwe, December 7-10, 2020, 2157-2161.
- [29] Alonso-Tristán, C., González-Peña, D., Díez-Mediavilla, M., Rodríguez-Amigo, M. and García-Calderón, T. (2011). Small hydropower plants in Spain: A case study, *Renewable and Sustainable Energy Reviews*, 15: 2729 - 2735.
- [30] Ajuwape, T. and Ismail, O.S. (2011). Design and Construction of a 5 kW Turbine for a Proposed Micro Hydroelectric Power Plant Installation at Awba Dam, *International Journal of Electrical and Power Engineering*, 5(3): 131 – 138.
- [31] Haidar. M.A, Senan, F. M, Noman, A. and Taha R. (2012). Utilization of Pico hydro generation in domestic and commercial loads. *Renewable and Sustainable energy reviews*, 16: 518-524.
- [32] Matewos, M. and Minaye, E. (2017). Designing Portable Micro - Hydro for Small Scale Hydro Power Plant Construction, *International Journal of Engineering and Technology*, 7(4): 515 – 518.
- [33] Zahnd, A. and Kimber, H. M. (2009). Benefits from a renewable energy village electrification system, *Renewable Energy*, 34: 362–368.
- [34] Ohunakin, O. S., Ojolo, S. J. and Ajayi, O. O. (2011). Small Hydropower (SHP) Development in Nigeria, *Renewable and Sustainable Energy Reviews*, 15: 2006 – 2013.
- [35] Manohar, K. and Adeyanju, A. A. (2009). Hydropower resources in Nigeria, *Journal of Engineering and Applied Sciences*. 4(1): 68-73.
- [36] National Agency for Science and Engineering Infrastructure (NASeni) (2013). Powering the Nation through NASeni's Small Hydro Power, Culled from NASeni Watch, January 2013, 1(2): 1 – 2.
- [37] Akuru, U.B. and Okoro, O.I. (2011). A Prediction on Nigeria's Oil Depletion Based on Hubbert's Model and the Need for Renewable Energy, *ISRN Renewable Energy*, 2011, Article ID 285649, 2011.
- [38] Edeoja, A. O., Ekoja, M. and Yusuf, T. A. (2019): Influence of Penstock Outlet, Number of V-Blades, Flat Blade Lateral Twist Angle and Hub to Blade Ratio on the Performance of a Simplified Pico Hydropower System, *Athens Journal of Technology and Engineering*, 6(2): 115-140. <https://doi.org/10.30958/ajte.6-2-4> doi=10.30958/ajte.6-2-4
- [39] Edeoja, A. O., Ibrahim, J. S., Ochonu, L. (2018b). Estimated Power Output from a Simplified Pico Hydropower System, *Journal of Energy Research and Reviews*, 1(1): 1-16.
- [40] Edeoja, A. O., Ajeibi, L. E., Effiong, A. D. (2017c). Influence of Penstock Outlet Diameter and Turbine Hub to Blade Ratio on the Performance of a Simplified Pico Hydropower System, *International Journal of Precious Engineering Research and Applications*, 2(5): 31-46.
- [41] Chanudet, V., Descloux, S., Harby, A., Sundt, H., Hansen, B. H., Brakstad, O., Serça, D. and Guerin, F. (2012). Gross CO₂ and CH₄ Emissions from the Nam Ngum and Nam Leuk Sub-Tropical Reservoirs in Lao PDR, *Science of the Total Environment*, 409, pp. 5382 – 5391.
- [42] Hussey, K. and Pittock, J. (2012). The Energy–Water Nexus: Managing the Links between Energy and Water for a Sustainable Future, *Ecology and Society*, 17(1): 31 – 39, Resilience Alliance.
- [43] Amor, M. B., Pineau, P., Gaudreault, C. and Samson, R. (2011). Electricity Trade and GHG Emissions: Assessment of Quebec's Hydropower in the North-eastern American Market (2006– 2008), *Energy Policy*, 39: 1711 – 1721.
- [44] Abbasi, T. and Abbasi, S.A. (2011). Small hydro and the environmental implications of its extensive utilization, *Renewable and Sustainable Energy Reviews*, 15: 2134 – 2143.
- [45] Nikolaisen, P. (2015). 12 Mega dams that changed the world but not necessarily for the better. Available from: <http://www.tu.no/artikler/12-megadammer-som-endret-verden/223528>

- [46] Yi-Fan, D., De-Shan, T. and Ting, W. (2011). Benefit Evaluation on Energy Saving and Emission Reduction of National Small Hydropower Ecological Protection Project, *Energy Procedia*, 5: 540 – 544.
- [47] Zeilhofer, P. and Mauro de Moura, R. (2009). Hydrological changes in the Northern Pantanal caused by the Manso dam: Impact analysis and suggestions for mitigation, *Ecological Engineering*, 35: 105 – 117.
- [48] Bukar, M. and Suleiman, A. A. (2022). Design and Performance Evaluation of Pico Hydropower Generation, *International Journal of Information, Engineering & Technology*, 11(7): 37-46.
- [49] Yuniarti, N., Hariyanto, D., Yatmono, S. and Abdillah, M. (2021). Design and Development of IoT Based Water Flow Monitoring for Pico Hydro Power Plant, *International Journal of Interactive Mobile Technologies*, 15(7): 69-80.
- [50] Schröder, H. C. (2018). Large-scale High Head Pico Hydropower Potential Assessment, Universität Stuttgart. - Stuttgart: Institut für Wasser- und Umweltsystemmodellierung, 12-24.
- [51] Setyawan, E. Y., Nakhoda, Y. I., Krismanto, A. U., Mustiadi, L., Yandri, E. and Burlakovs, J. (2020). Design and Construction of Single Phase Radial Flux Permanent Magnet Generators for Pico hydro Scale Power Plants Using Propeller Turbines in Water Pipes, *E3S Web of Conferences* 188, 00006 (2020), ICESTI 2019, <https://doi.org/10.1051/e3sconf/202018800006>.
- [52] Smits, M. and Bush, S. R. (2010). A light left in the dark: The practice and politics of Pico-hydropower in the Lao PDR, *Energy Policy*, 38: 116 – 127.
- [53] Susanto, J. and Stamp, S. (2012). Local installation methods for low head Pico-hydropower in the Lao PDR, *Renewable Energy*, 44: 439 – 447.
- [54] Horlacher, H., Heyer, T., Ramos, C. M. and da Silva, M. C. (2012). Manage Hydropower Impacts through Construction and Operation, *Comprehensive Renewable Energy*, 6: 49 - 91.
- [55] Dametew, A. W. (2016). Design and Analysis of Small Hydro Power for Rural Electrification, *Global Journal of Researches in Engineering: Electrical and Electronics Engineering*, 16(6), Version 1.0: 24 – 45.
- [56] Hunachal, S. M., Kumar, M., Oak, S., Burate, A., Kanekar, R. and Shirke, P. (2016). Design and Development of Pico Hydro Power System by Irrigation Water, *International Research Journal of Engineering and Technology (IRJET)*, 3(8): 1904 – 1910.
- [57] da Luz, R., da Rocha, T. A. G., de Souza, J., Risso, A., Rossini, E. G. and Beluco, A. (2020). Pico Hydro for power generation with Small-scale hydroplants, *Research Inventy: International Journal of Engineering and Science* 10(7): 17-22.
- [58] Lahimer, A.A., Alghoul, M.A., Sopian, K., Amin, N., Asim, N., Fadhel, M.I. (2012). Research and development aspects of Pico-hydropower, *Renewable and Sustainable Energy Reviews*, 16: 5861–5878.
- [59] Gautam, B. (2012). Low Head Pico-Hydro: A Robust Rural Renewable Energy Technology for Remote Rural Areas, *Hydro Nepal*, Issue 11: 64-66, July 2012.
- [60] Aidhen, A. S. and Gaikwad, P. H. (2016). Pump as Turbine with Induction Generators in Pico Hydro for Electrification of High Terrain Areas: A Review, *International Journal of Current Engineering and Technology*, 6(5): 1543-1548.
- [61] Ananthapadmanabhan, G. S. and Shouri, P. V. (2017). Pico Hydro Power Generation from Grey water in High Rise Buildings: Feasibility and Economic Analysis, *International Journal of Innovative Research in Science, Engineering and Technology*, 6(6): 134-142.
- [62] Basar, M. F., Rais, N. A. M., Hassan, F. S. M., Ibrahim, K. A. and Sopian, K. (2019). Economic Analysis on Design of a Simple Hydraulic Reaction Type Turbine for Low-Head Low-Flow Pico Hydro, *International Journal of Innovative Technology and Exploring Engineering*, 9(2): 3976-3970.
- [63] Nimje, A. A. and Dhanjode, G. (2015). Pico-Hydro-Plant for Small Scale Power Generation in Remote Villages, *IOSR Journal of Environmental Science, Toxicology and Food Technology*, 9(1 Ver. III): 59-67. Available at www.iosrjournals.org.
- [64] Rekha. A. M., Amulya. T. H. M., Soumyashri. R., Raghu. G. M. and Renuka. R. (2019). Hydraulic Design of Pico Hydro Power System from Sewage Water at S.S Layout, Davangere, Karnataka, *International Journal of Engineering Science and Computing*, 20278-20281.
- [65] Titus, J. and Ayalur, B. (2019). Design and Fabrication of In-line Turbine for Pico Hydro Energy Recovery in Treated Sewage Water Distribution Line, 2018 5th International Conference on Power and Energy Systems Engineering, CPESE 2018, 19–21 September 2018, Nagoya, Japan, *Energy Procedia*, 156: 133 – 138.
- [66] Williamson, S. J., Lubitz, W. D., Williams, A. A., Booker, J. D. and Butchers, J. P. (2020). Challenges Facing the Implementation of Pico-Hydropower Technologies, *Journal of Sustainability Research*, 2(1): 1-35.

- [67] Williamson, S.J., Stark, B.H. and Booker, J.D. (2011). Low Head Pico Hydro Turbine Selection using a Multi-Criteria Analysis, World renewable Energy Congress 2011 (Hydropower Applications): 1377 – 1385, 8 – 13 May 2011, Linköping, Sweden.
- [68] Vicente, S. and Bludszuweit, H. (2012). Flexible design of a Pico-hydropower system for Laos communities, *Renewable Energy* 44 (2012) 406e413
- [69] Cobb, B.R. and Sharp, K.V. (2013). Impulse Turbine Performance Characteristics and Their Impact on Pico-Hydro Installation, *Renewable Energy*, 50: 959-964.
- [70] Alexander, K.V. and Giddens, E.P. (2008), Optimum Penstocks for Low Head Microhydro Schemes, *Renewable Energy*, 33: 507 –519, Elsevier Limited.
- [71] Edeoja, A. O., Ibrahim, S. J. and Kucha, E. I. (2015b). Conceptual Design of a Simplified Decentralized Pico Hydropower with Provision for Recycling Water, *Journal of Multidisciplinary Engineering Science and Technology (JMEST)*, 2(2).
- [72] Gaiser, K., Erickson, P., Stroeve, P. and Delplanque, J. (2016). An experimental investigation of design parameters for pico-hydro Turgo turbines using a response surface methodology, *Renewable Energy*, 85: 406 – 428.
- [73] Karrupusamy, P. (2020). Performance Analysis of Multiple Pico Hydro Power Generation, *Journal of Electrical Engineering and Automation (EEA)*, 2(2): 92-101.
- [74] Uniyal, V., Kanojia, N. and Pandey, K. (2016). Design of 5kw Pico Hydro Power Plant Using Turgo Turbine, *International Journal of Scientific & Engineering Research*, 7(12): 363 – 367.
- [75] Edeoja, A. O. and Tarka, J. A. (2018b). Shaft Power of a Simple Pico Hydropower System as a Function of the Flow Rate and Net Head Product, *International Journal of Engineering Technology Research & Management*, 2(3): 38-48.
- [76] Edeoja, A. O., Ekoja, M., Ibrahim, J. S. (2018c). Turbine Dimensionless Coefficients and the Net Head/Flow Rate Characteristic for a Simplified Pico Hydro Power System, *Journal of Engineering Research and Reports*, 1(1): 1-17.
- [77] Derakhshan, S. and Kasaeian, N. (2012). Optimal design of axial hydro turbine for micro hydropower plants, 26th IAHR Symposium on Hydraulic Machinery and Systems, IOP Conf. Series: Earth and Environmental Science, 15, (2012) 042029
- [78] Edeoja, A.O., Ibrahim, J.S., Kucha, E.I. (2016a). Investigation of the Effect of Penstock Configuration on the Performance of a Simplified Pico-Hydro System, *British Journal of Applied Science and Technology*, 14(5): 1-11.
- [79] Edeoja, A. O., Ibrahim, J. S., Tuleun, L. T. (2016b). Effect of Blade Cross-Section on the Performance of a Simplified Pico-Hydro System, *American Journal of Engineering Research*, 5(12): 1-9.
- [80] Edeoja, A. O. and Awuniji, L. (2017). Experimental Investigation of the Influence of Penstock Configuration and Angle of Twist of Flat Blades on the Performance of a Simplified Pico-Hydro System, *European Journal of Engineering Research and Science*, 2(7): 14-22.
- [81] Edeoja, A. O., Ekoja, M., Ibrahim, J. S. (2017a). Effect of Nozzle Area Ratio on the Performance of a Simplified Pico Hydropower System, *Nigerian Journal of Pure and Applied Sciences*, 9(1): 232-249.
- [82] Edeoja, A. O., Ekoja, M. and Tuleun, L. T. (2017b). Effect of Penstock Area Reduction and Number of Turbine V-Blades on the Performance of a Simple Pico-Hydropower System, *European Journal of Advances in Engineering and Technology*, 4(11): 797-806.
- [83] Edeoja, A. O., Edeoja, J. A., Ogoji, M. E. (2017d). Effect of the Included Angle of V-Shaped Blade on the Performance of a Simplified Pico-Hydro System, *International Journal of Scientific & Engineering Research*, 8(8): 1208-1213.
- [84] Ipilakyya, D. T., Edeoja, A. O., Kulugh, (2017). Influence of Penstock Outlet Diameter and Flat Blade Lateral Twist Angle on the Performance of a Simplified Pico Hydropower System, *International Journal of Trend in Scientific Research and Development*, 1(5): 394-406.
- [85] Edeoja, A. O. and Tarka, J. A. (2018a). Effect of Penstock Diameter of a Simple Pico Hydro System on Shaft Power, *Elixir Mech. Engg.*, 118: 50610-50622.
- [86] Edeoja, A. O., Ibrahim J. S., Archigbenda, V. (2018a). Influence of Turbine Runner Diameter on the Performance of a simplified Pico Hydropower System, *Journal of Technology, Industrial Studies and Science*, 2(2). Dept of Voc. & Tech. Edu., Benue State University, Makurdi.
- [87] Chukwunke J. L., Achebe C. H., Okolie P. C., Okwudibe H. A. (2014). Experimental Investigation on the Effect of Head and Bucket Splitter Angle on the Power Output of a Pelton Turbine. *Journal of Information Engineering and Applications*, 4(10), 2014.

- [88] Farriza, M.B., Boejang, H., Masjuri, M., Arasc, M.S.M., Razik, N.H.A., Mat, S. and Sopian, K. (2015). Evolution of Simple Reaction Type Turbines for Pico-Hydro Applications, *JurnalTeknologi (Science and Engineering)*, 77(32): 1 – 9.
- [89] Mungwe, J., Mandelli, S. and Colombo, E. (2016). Community Pico and micro hydropower for rural electrification: experiences from the mountain regions of Cameroon, *AIMS Energy*, 4(1): 190-205. DOI: 10.3934/energy.2016.1.190.
- [90] At-Tasneem, M.A., Azam, W. M. and Jamaludin, U. (2014). A Study on the Effect of Flow Rate on the Power Generated by a Pico Hydro Power Turbine, *World Applied Sciences Journal 30 (Innovation Challenges in Multidisciplinary Research & Practice)*, 420-423.
- [91] Benzerdjeb, A., Abed, B., Hamidou, M. K., Bordjane, M. and Gorlov, A. M. (2017). Experimental Study on the Effect of Water Velocity on the Performance of a Cross-Flow Turbine, *International Journal of Renewable Energy Research*, 7(4): 2111-2119.
- [92] Newell, B., Tippet, S., and Friedley, A. (2020). The Advantages to Micro-Hydro and Pico-Hydro Electric Energy. Poster submitted to the Research and Scholarship Conference, Western Carolina University. Available at: <https://libres.uncg.edu/ir/wcu/listing.aspx?styp=ti&id=31340>.
- [93] Dela Rosa, C. S.G., Flores III, G. B. B., Overos, M. D. B and Sanchez, J. (2018). Design and Development of a Pico-hydro Pelton Turbine Bucket Using Recycled Polyethylene Terephthalate Bottles, 6th DLSU Innovation and Technology Fair 2018, De La Salle University, Manila, Philippines, November 22 & 23, 2018.
- [94] Yahya, A. K., Munim, W. N. W. A. and Othman, Z. (2014). Pico-Hydro Power Generation Using Dual Pelton Turbines and Single Generator. Available at <https://www.researchgate.net/publication/269306995>. DOI: 10.1109/PEOCO.2014.6814495.
- [95] Sanunnaam, N., Sajjakulnukit, B. and Songprakorp, R. (2012). Techno - socio - economic Assessment of Pico Hydropower Installations in the Northern Region of Thailand, 2012 International Conference on Environment Science and Engineering IPCBEE, 32(2012): 114-118.
- [96] Park, J.H., Lee, N.J., Wata, J. V., Hwang, Y.C. Kim, Y.T and Lee, Y.H (2012). Analysis of a Pico hydro turbine performance by runner blade shape using CFD, *26th IAHR Symposium on Hydraulic Machinery and Systems IOP Publishing IOP Conf. Series: Earth and Environmental Science 15(2012)042031*
- [97] Prasanna, N. H., Rajat, P., Santosh, K. S., Tejas, M. and Vibhuti, N. A. (2019). Design and Fabrication of Pico Hydro Turbine, *International Journal of Engineering Research & Technology*, 7(7): 1-4.
- [98] Róźowicz, S., Goryca, Z., Peczkis, G. and Korczak, A. (2019). Pico hydro generator as an effective source of renewable energy, *PrzeglądElektrotechniczny*, ISSN 0033-2097, R. 95 NR 4/2019: 200-204.
- [99] Mon, E. E., Khaing, C. C. and Lynn, A. Z.(2019). Design, Construction and Performance Testing of 1 kW Pelton Turbine for Pico Hydro Power Plant, *International Journal of Science and Engineering Applications*, 8(7): 192-196.
- [100] Kapoor, R. (2013). Pico Power: A Boon for Rural Electrification, *Advance in Electronic and Electric Engineering*, 3(7): 865-872.
- [101] Andres, N. S., Manalang, R., Gache, P., Poblete, R., Italia, J. L., Urganay, J., Servolo, R. and Gamboa, E. (2022). Development of a Pico-Hydro Electric Generator with 3D-Printed Pelton Turbine, *Engineering Innovations*, 1: 29-38. Doi:10.4028/p-gu9d87.
- [102] Rajan, R. V., Suresh, K., Ipe, S., Kurup, A. R. and George, A. M. (2016). Pico-Hydro Electric Power Generation from Residential Water Tank, *Int. J. Chem. Sci.*, 14(1): 421-426.
- [103] Bhalshankar, S. S. (2018). Home Water-Tank Pico-Hydro Power Generator Modeling and Analysis for Smart Home Distributed Generation System, *International Journal of Electrical Engineering & Technology (IJEET)*, 9(4): 1–8.
- [104] Xuhe, W., Baoshan, Z., Lei, T., Jie, Z., Shuliang, C. (2014). Development of a pump-turbine runner based on multi-objective optimization, *27th IAHR Symposium on Hydraulic Machinery and Systems (IAHR 2014)*, IOP Conf. Series: Earth and Environmental Science, 22.
- [105] Alnakhlani, M. M., Mukhtar, D. A. Himawanto, A. Alkurtehi and D. Danardono (2015). Effect of the Bucket and Nozzle Dimension on the Performance of a Pelton Water Turbine, *Modern Applied Science*; 9(1): 25-33.