

System of biological approaches to interpret seed dormancy and germination

Abstract

Seed dormancy prevents an intact, viable seed from successfully germinating under ideal circumstances. In order for germination to occur when conditions are likely to be favourable for forming a new plant generation, this barrier to germination has developed differently among species through adaptation to the local environment (Bewley, 1997). Although there is still a gap between biochemistry and morphogenesis, it is being bridged in many places slowly and methodically. This study attempts to evaluate the improvements made at a particular bridge, seed dormancy. One element of the phenomena of growth cessation is seed dormancy, which has as its central challenge the challenge of maintaining a growth potential without compromising biological integrity. It can be divided into primary and secondary dormancy. Due to endogenous causes and/or environmental conditions experienced by the mother plant, primary dormancy is developed during seed development. Non-dormant seeds can also enter a state of secondary dormancy, which is a form of dormancy that happens when germination conditions are unfavourable. This review will help in briefing the difference between dormant condition and quiescent condition of seed. Quiescence can be considered as a short period of dormancy. But, unlike dormancy, quiescence is reversible upon the return of suitable conditions. Numerous physical and physiological techniques, like as scarification and stratification, can be used to break the dormant state of seeds. Various dormancy breaking methods applied in several crop has been noted in this study. Roles of several plant hormones including Gibberellin (GA) and Abscisic acids (ABA) are regarded as the two main hormones that regulate seed development and germination in an antagonistic manner. This study focuses in particular on the molecular basis of ABA regulation of seed maturation, which includes regulation of dormancy. Various dormancy breaking methods applied in several crop mentioned in this review could also help researcher to further study the dormancy pattern and breaking of it on that particular crop.

Keywords: Abscisic acids, dormancy, germination, gibberellin

Introduction:

Dormancy in the seed makes it difficult for it to fully germinate under ideal circumstances. This barrier to germination has developed differently in each species as a result of adaptation to the local environment, so that germination takes place when the conditions are most likely to be favourable for forming a new plant generation (Bewley, 1997). The failure of intact, viable seeds to finish germination under favourable environmental conditions is known as seed dormancy (Gao and Ayele, 2014). Dormancy can be classified as primary dormancy and secondary dormancy, depending upon when the induction of dormancy occurs. Primary dormancy is occurred during seed development due to endogenous factors and environmental

conditions experienced by the mother plant (Gao and Ayele, 2014). Seeds that exhibit primary dormancy can be overcome from the state of dormancy by a number of treatments, including after-ripening and cold stratification, refers to seed hydration or imbibition at low temperatures. When faced with conditions that are unfavourable to germination, nondormant seeds may also enter into the state of dormancy, and this type of dormancy is referred to as secondary dormancy (Kermode, 2005). Besides, lack of seed dormancy is undesirable because it may cause preharvest sprouting (PHS). It is a survival mechanism by which seeds can delay germination until the right environmental conditions for seedling growth and development.

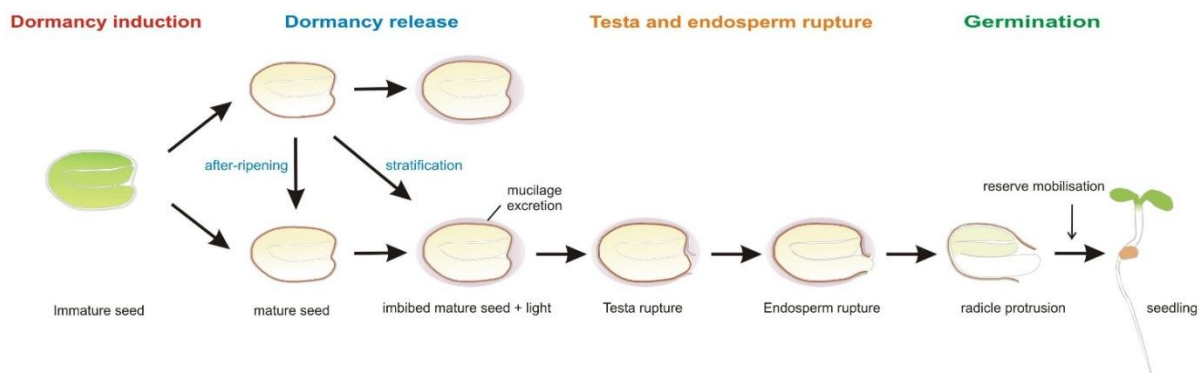

Fig-1: Seed Dormancy and Germination (Bentsink and Maarten Koornneef, 2008).

Objective:

- To figure out the amenities and drawbacks of seed dormancy
- To gain knowledge of biology of dormancy.
- To understand how plant growth hormones, affect seed dormancy.
- To understand relation between seed germination and dormancy.
- To gain knowledge about how seeds develop, particularly how gibberellins and abscisic acids influence seed dormancy.
- To know the different methods of breaking dormancy.

Causes of Seed dormancy:

Some of the most common factors affecting seed dormancy are listed below:

- ❖ **Light:** The majority of plant seeds develop successfully in both darkness and light. Latent seeds are those found in plants like lettuce (*Lactuca sativa*) that do not germinate in the dark but do so when they are exposed to light. Darkness thereby prevents the germination of such plants.
- ❖ **Temperature:** In most plants, low temperature encourages germination while high temperature also induces dormancy. Seeds of temperate plants including apple, walnut, and pinus remain dormant (nearly a week) when it's not exposed to chilly temperatures (1° to

5°C) for an extended period of time. In other cases, such as in desert regions, germination of seeds requires extremely high temperatures (60 to 70 degrees Celsius) during the day and low temperatures (5 to 10 degrees Celsius) at night (Hilthrost, 1995)

- ❖ **Presence of Tough Seed Coat:** Leguminous plant seeds, including those of pea, clovers, beans and alfalfa, block the entry of water into the seed, delaying germination. A hard coat also prevents the exchange of gases, such as oxygen, which are essential for seed respiration.
- ❖ **Presence of Inhibitory Chemicals:** Ascorbic acid, ferulic acid, and coumarin are a few naturally occurring substances that cause dormancy in seeds and can be found in the embryo, endosperm, or seed coats of certain plants, including Xanthium and Cucurbita.

Quiescence vs Dormancy		
	Quiescence	Dormancy
DEFINITION	Quiescence is a kind of resting stage in normal or non-dormant seeds which delays the germination due to the absence of suitable conditions such as adequate moisture, temperature, etc., for the seed germination	Dormancy is an evolutionary adaptation that prevents seed germination under unsuitable ecological conditions
TIME	Relatively short	Can be a few months to years
FAST PLANTS	Seen in fast plants	Not seen in fast plants
REVERSIBILITY	Can be reversed upon the return of suitable conditions	Cannot be reversed quickly

❖ Fig-2: On the Language and Physiology of Dormancy and Quiescence in Plants. Considine, *et al.* (2016).

Quiescence stage, temporary dormancy like phenomenon of seed:

One kind of dormant state in healthy, non-dormant seeds is called quiescence. It is a process that postpones seed germination because of the necessary moisture, temperature, and other factors are not present. However, the embryo's growth can resume at any point under ideal circumstances. Dormancy is an evolutionary adaptation that prevents seeds from germinating during unfavourable ecological conditions that would typically have a low probability of

seedling survival. Quiescence is the inability of a normal, non-dormant seed to germinate because of the absence of conditions suitable for germination (Harper, J.L., 1957).

Advantages of Seed dormancy:

- Allows seeds to germinate under ideal conditions and helps to pass through adverse condition.
- Enables the storage, transportation and handling of seeds.
- Allows sufficient time for embryo to develop.

Disadvantages of seed dormancy:

- Prevents prompt and uniform emergence of seedlings.
- Difficult to maintain plant population.
- Interferes in seed testing procedures.

Relation of Dormancy and Germination:

An entire dormant seed can sprout under the broadest range of typical physical environmental conditions possible for the genotype (Baskin & Baskin, 1998, 2004). The seed may show sensitivity to multiple aspects in addition to its basic requirements of oxygen, water, and a suitable temperature. One such factor is light. The dry seed first takes up water to start germination, then the embryo grows after that. The process of absorbing water typically has three phases: imbibition, or phase I, which is characterised by a quick initial uptake, and plateau period, or phase II (phase II). A further increase in water intake occurs as the embryo axis lengthens and penetrates the covering layers to complete germination (phase III) (Schopfer and Plachy, 1984; Manz *et al.*, 2005).

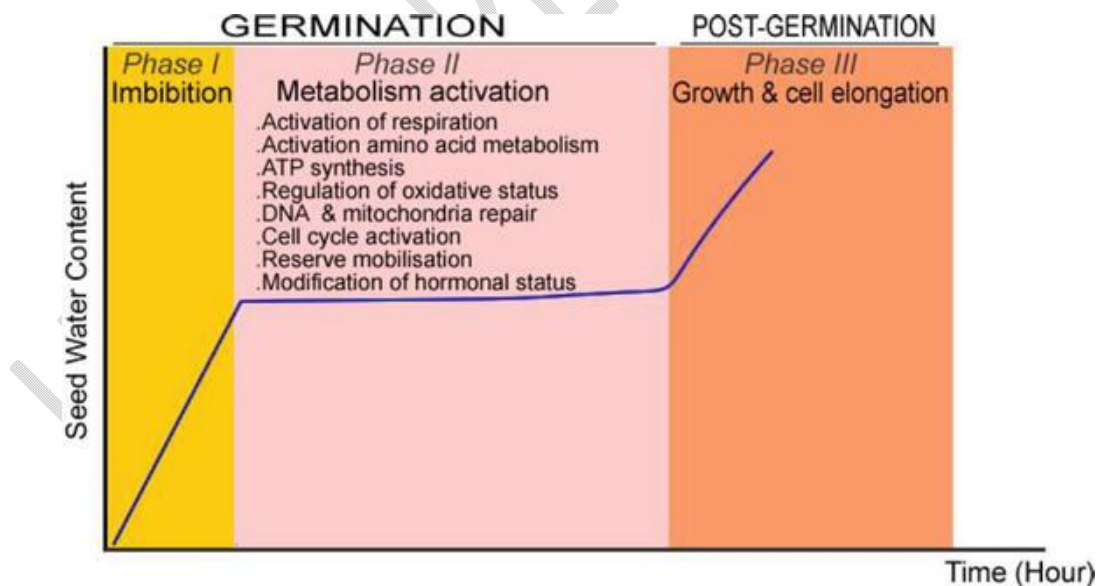

Fig-3: Stages of Seed germination (Schopfer and Plachy, 1984)

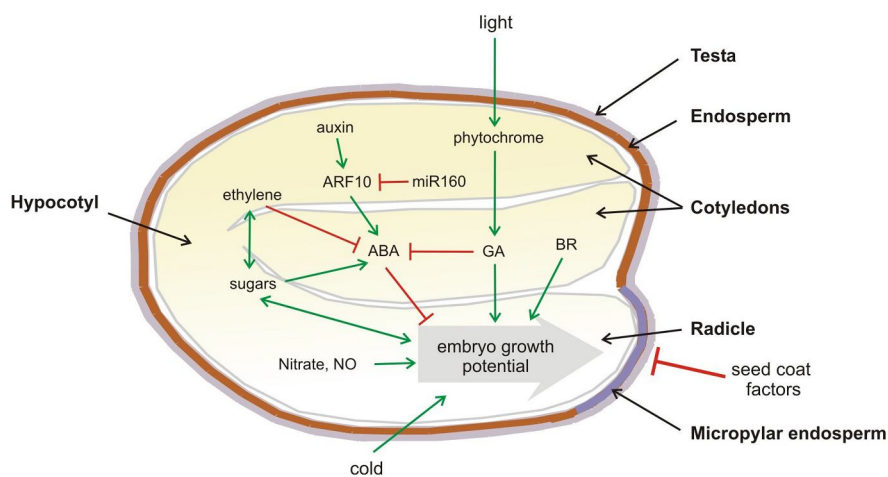

Fig 4: Simplified deliberation of processes controlling seed dormancy and germination in an Arabidopsis seed (Bentsink and Koornneef, 2008).

Types of Seed Dormancy:

1. Primary Dormancy:

- When the seed is still connected to the plant and survives until harvest, primary dormancy forms.
- This kind of dormancy developed during seed development as a result of internal causes or environmental circumstances that the mother plant confronted (Gao and Ayele, 2014). Depending upon the extent and location, primary dormancy is classified in to three types- a) Exogenous, b) Endogenous and c) Combinational dormancy.

a) Exogenous dormancy:

- External stimuli other than the embryo cause this kind of dormancy to occur. It can be further categorized into three types i.e. **i) Physical**, **ii) mechanical** and **iii) Chemical** dormancy.

i) Physical dormancy:

- Caused by the seed coat or seed covering layers that are impermeable to water or gas, thereby responsible for this kind of dormancy.

ii) Mechanical dormancy:

- During germination, the embryo is frequently resisted by the seed coat's physical constraints, such as when the water absorption pressure and development is insufficient to cause the seed coat to fracture. (Watson and cantliffe). This type of dormancy can be called mechanical dormancy.

iii) Chemical dormancy:

Chemical inhibitors that are present in the seed coat's outer layers cause chemical dormancy.

b) Endogenous dormancy:

Endogenous seed dormancy is the second important subcategory of primary seed dormancy.

- In this type of dormancy, a condition occurs which developed to prevent germination due to factors within the embryo.

Endogenous dormancy comes in two forms: morphological and physiological.

i) Morphological dormancy:

- The embryo in seeds that are in morphological dormancy is not fully formed when the seed is dispersed.
- Based on the embryo type seen in herbaceous flower crops, Atwater (1980) defined three types of morphological dormancy. These embryo types are simple, linear, and undifferentiated.
 - a. **Rudimentary-** Embryos are essentially a proembryo encased in a large endosperm. These can be discovered in the seeds of several different families, including the Ranunculaceae, Papaveraceae, and Araliaceae.
 - b. **Linear-** Torpedo-shaped and up to half the size of the seed, linear embryos are seen in seeds. The Apiaceae, Ericaceae, Primulaceae, and Gentianaceae are significant families and species in this group. (Geneve, 1998).
 - c. **Undifferentiated-**Dormancy appears at any stage of division of embryonic cells. Orchids are the best illustration of this type of dormancy.

ii) Physiological dormancy:

The embryo undergoes physiological changes during this type of dormancy, which frees the radicle from the confines of the seed coverings. Physiological dormancy consists of nondeep, deep and intermediate categories.

❖ Nondeep type:

- This type of dormancy is frequently ephemeral and disappears after dry storage.
- Nondeep physiological dormancy for the majority of cultivated grains may last for 1 to 6 months before dissipating with dry storage under appropriate handling conditions. (Geneve, 1998).

❖ Deep type:

- Deep dormancy is controlled by the factors within the embryo.
- The excised embryos exhibit physiologically dwarfing, stunted growth and rosette like structure in this type of dormancy.

iii) Intermediate type:

It is a regulating system that may exist in the embryo's surrounding tissues as well as the seed coat.

C) Combinational or double dormancy:

It is defined that where two or more dormancy types occur in the seed, such as morpho-physiological dormancy, where there is an under developed embryo and physiological dormancy or exo-endodormancy that combines seed coat dormancy.

2) Secondary dormancy:

- When the environment is unfavourable for germination, seeds that have emerged from primary dormancy frequently go into secondary dormancy (Crocker, 1916).
- Examples of these circumstances include unfavourable temperature, protracted light or darkness, water stress, low oxygen levels, etc.
- Secondary dormancy is synonyms to induced dormancy and is brought on by events that take place after the seed has been dispersed (Kebreab and Murdoch, 1997).

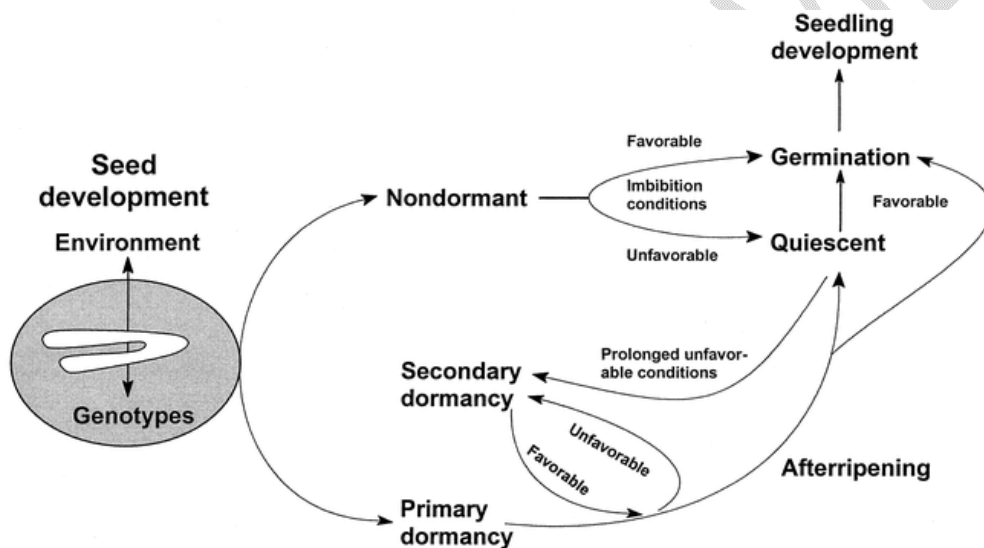

Fig- 5: Seed dormancy (Nadella *et al*, 2004).

Roles of plant hormones in seed dormancy:

A plant hormone is any chemical that is produced in one part of the plant that has a targeted function elsewhere. Each plant hormone plays multiple roles, depending upon site of action. Certain hormones keep seeds in dormant stage while others cause seeds to break dormancy and initiate germination. According to their function plant hormones can be classified into three categories: A) Growth hormone, B) Stress hormone and C) Shock hormone.

	Germination	Growth to Maturity	Flowering	Fruit Development	Abscission	Seed Dormancy
Gibberellin	✓	✓	✓	✓	✗	✗
Auxin	✗	✓	✓	✓	✗	✗
Cytokinins	✗	✓	✓	✓	✗	✗
Ethylene	✗	✗	✓	✓	✓	✗
Abscisic Acid	✗	✗	✗	✗	✓	✓

Fig-6: Plant hormones, types and functions (Humagain, 2018)

a. Growth Hormone:

Auxin and Cytokinins are considered as growth hormone.

▪ Auxin:

Synthesized in shoot and root meristematic tissue, young leaves, mature root cells.

✓ Effect in dormancy:

- Several studies, showed that auxin possesses positive effects on seed dormancy (Shuai *et al.*, 2016).
- At the molecular level, Liu *et al.* (2013) showed that auxin plays a role in primary dormancy through activation of ABA signalling, designating auxin as a dormancy promotor.
- Matilla (2020) conducted a thorough analysis of auxin's role in embryogenesis, primary dormancy, and germination.

▪ Cytokinin:

Synthesized in root and shoot meristematic tissue.

✓ Effect in dormancy:

- Cohn and Butera, (1982) summarized that cytokinins alone can disrupt seed dormancy in numerous species.
- Babiker *et al.* (2000) and Matilla noticed a similar type of experiment (2000).
- Rousselin *et al.* (1992) discovered cytokinin-resistant mutants of *Nicotiana plumbaginifolia* that have reduced seed dormancy and pleiotropic seed effects that may be related to cytokinin-ABA interactions.

b. Stress Hormones:

Gibberellic acid, Ethylene and Brassinosteroids are considered as stress hormone.

▪ Gibberellic acid:

Synthesized in the embryo and germinating seeds, apical meristems and young leaves.

✓ Effect in dormancy:

- a. Gibberellins (GA) counteract the effects of ABA, induce germination, and relieve dormancy.
- b. In developing seeds, GA biosynthesis does not appear to be involved in the formation of primary dormancy. (Groot *et al.*, 1987).
- c. Similar observation was noticed by Bewley (1997) that GA is required to remove the mechanical constraint that the seed-covering layers create, by weakening of the tissues surrounding the radicle and concluded that localization of seed GA biosynthesis in the Arabidopsis radicle is consistent with the hypothesis that embryonic GA is released and triggers the weakening of seed-covering layers.
- d. Similar observation recorded by Ogawa *et al.* (2003) who observed that some GA responsive genes are expressed in non-GA-producing seed tissues, responsible for breaking dormancy.

▪ **Ethylene:**

Released in mature cells in mineral deficient condition. Synthesized in tissues of ripening fruit, nodes of stems, senescent leaves and flowers.

✓ **Effect in dormancy:**

- a. Ethylene helps seeds germinate and counteracts the negative effects of ABA.
- b. Ethylene is said to be involved in the promotion of germination of non-dormant seeds of many species, according to Corbineau *et al.* (1990) and Esashi (1991).
- c. According to Leubner-Metzger *et al.* (1998), tobacco needs endogenous ethylene to encourage endosperm rupture.
- d. Beaudoin *et al.* (2000) suggested that ethylene and ABA signal transduction pathways interact strongly and came to the conclusion that ethylene can increase germination by directly interfering with ABA signalling.
- e. Ghassemian *et al.* supported this experiment (2000).
- f. In conclusion, it can be said that ethylene probably won't be able to positively regulate germination on its own; instead, it will need to interfere with ABA signalling.

▪ **Brassinosteroids:**

Released in mature cells during oxygen deficient condition. Released in root cell during disease stress condition.

✓ **Effect in dormancy:**

- a. Brassinosteroids upgrade seed germination. Takeuchi *et al.* (1995) noted that BR application increase germination of certain parasitic angiosperms.
- b. Yamaguchi *et al.* (1987) reported similar type of observation in cereals, Steber and McCourt (2001) in Arabidopsis mutants and in tobacco by Leubner-Metzger, (2001).
- c. Steber *et al.* (1998) and Steber and McCourt (2001) recommended BR-dependent germination interactions between BR and GA signalling in seeds that.
- d. Ullah *et al.* (2002) also supported this in the germination phenotype of the *gpa1* mutant of Arabidopsis.

c. Shock hormone:

Abscisic acid (ABA) is considered as shock hormones.

- **Abscisic acid(ABA):**

- ✓ **Effect in dormancy:**

- a. ABA is a positive regulator of the induction of dormancy and a negative regulator of germination.
- b. o Finkelstein et al. (2002) found that when water content in orthodox seeds falls during development, ABA builds up and primary dormancy is induced.
- c. Frey *et al.* (2004) in *N. plumbaginifolia*, Schopfer and Plachy (1984) in rapeseed, and Manz *et al.* (2005) in *N. tabacum* recorded that the transition from water uptake (phases 1 and 2) during germination to water absorption during post-germination growth (phase 3) was inhibited by ABA.
- d. They came to the conclusion that ABA decreases phase 3 water uptake, endosperm rupture, additional embryo extension, and seedling development following radicle emergence, but that ABA does not inhibit phase 1 water uptake, phase 1 embryo extension growth, or phase 1 testa rupture.
- e. Homrichhausen *et al.* (2003) supported this experiment in carrot.

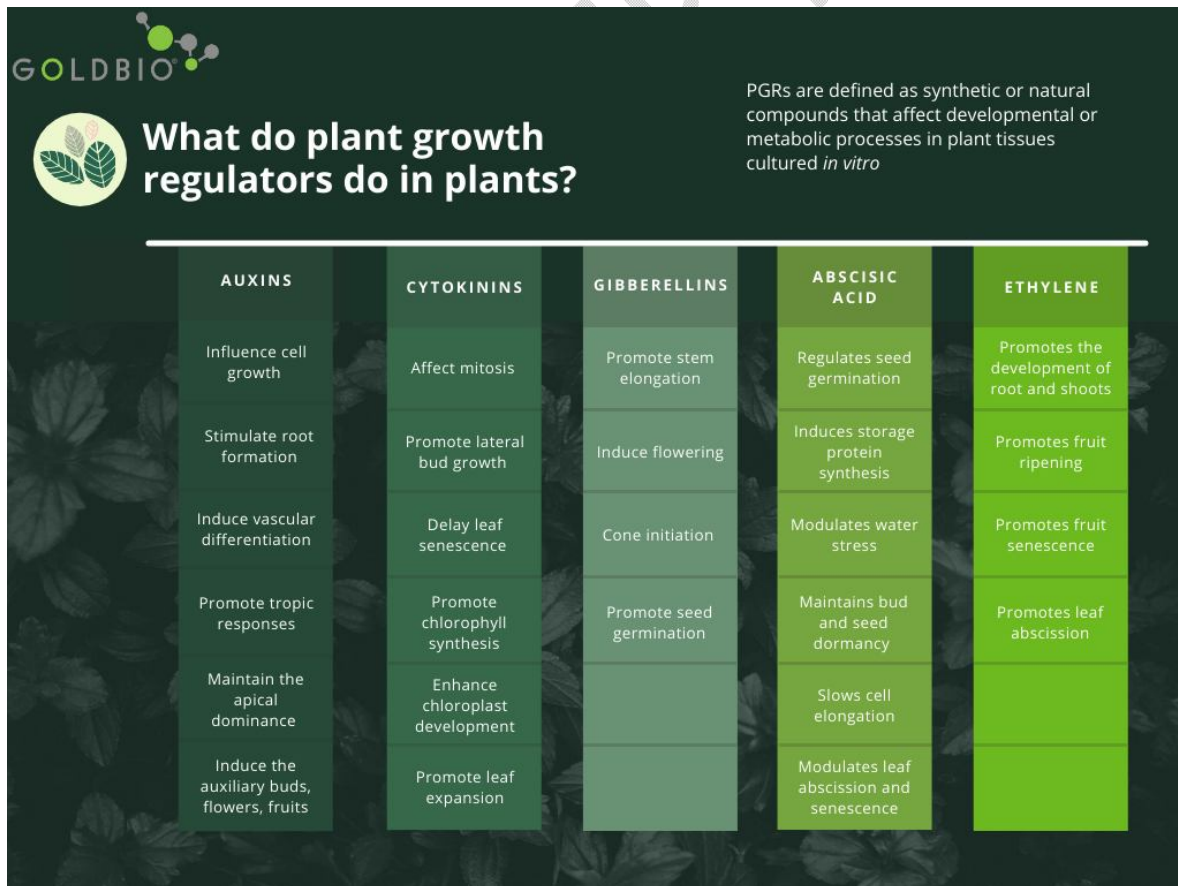

Fig-7: Optimization of growth regulators (Adugna *et al.*, 2020)

Role of Gibberellins and Absciscic Acids on Seed Development and their effect on seed dormancy:

Seed development

Seed development is a pivotal process in the life cycle of angiosperms which is initiated by the double fertilization leads to the development of the embryo and the endosperm. Embryo development and seed maturation are the two main stages of seed development. Embryogenesis, which is a morphogenesis phase, starts with the formation of a single-cell zygote and ends when all embryo structures have been formed (Mayer *et al.*, 1991). After embryogenesis it is followed by a growth phase during which the embryo fills the seed sac (Goldberg *et al.* 1994). Raz *et al.* (2001) studied that at the end of the embryo growth phase, cell division in the embryo arrests. Thereafter, the seed, consists of a full sized embryo, undergoes maturation during the phase accumulation of food reserves occurs and dormancy and desiccation tolerance develops (Goldberg *et al.* 1994).

ABA and GA Levels During Seed Development:

Level of ABA during Seed Development

In seed development in *Arabidopsis*, Kanno *et al* (2010) observed a peak of ABA level in the whole silique in the middle of development (around nine days after flowering (DAF)), and after 12 DAF, ABA increased until late stage of development (21 DAF) and detected mostly in the seeds during the middle stage and in the envelopes during the late stage of maturation.

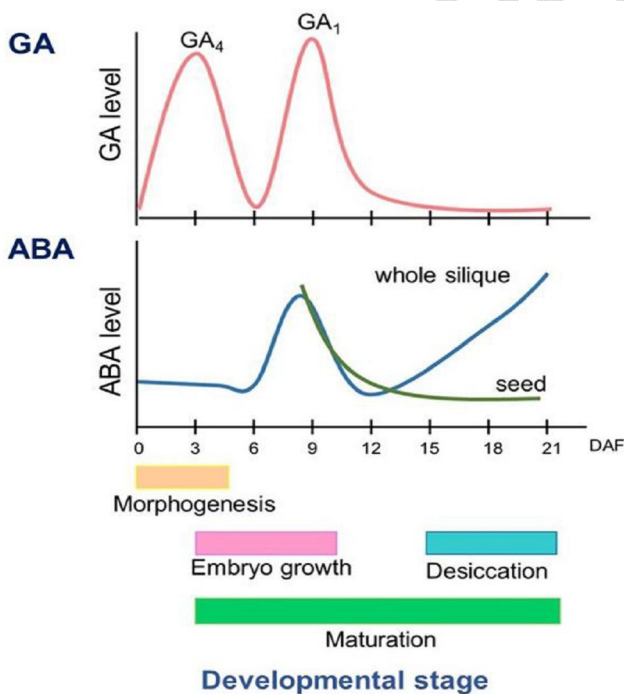

Figure-8: The level of GA and ABA during seed development of *Arabidopsis*. Schematic trend of hormone accumulation during seed development [Hu *et al.*, 2018]. DAF: day after flowering.

Lefebvre *et al.* (2006) demonstrated that nine-cis epoxy carotenoid dioxygenase (NCED) is the key regulatory enzyme in the ABA biosynthetic pathway. According to Kanno *et al.* (2010), of the five NCED genes in *Arabidopsis*, AtNCED6 and AtNCED9 are responsible for a high amount of ABA during mid-seed development, whereas AtNCED2 and AtNCED3 are responsible for ABA accumulation during the later stages of entire silique growth. Tuan *et al.* (2018) reported that in the seed development of wheat, there are two peaks of ABA level. Suzuki *et al.* (2000) observed that the ABA synthesized during the late phase of seed development about 35-40 days after pollination (DAP) is associated with the level of dormancy. Besides, rice and triticale have one peak of ABA level in their seed development. Liu *et al.* (2014) opined that in rice seeds, the accumulation of ABA involved in the induction of dormancy occurs during the early and middle stages of seed development (10–20 DAP), earlier than in wheat. Fidler *et al.* (2016) reported in triticale grains, peak ABA accumulation was around 35 DAP, before a significant loss of water.

GA Level during Seed Development

Only four of the more than 130 GAs that have been found in plants, bacteria, and fungi—and it is believed that GA₁, GA₃, GA₄, and GA₇ operate as bioactive hormones. The two most prevalent bioactive GAs in many plants, including *Arabidopsis*, are GA₁ and GA₄. According to Yamaguchi (2008), the non-13-hydroxy pathway, which predominates in *Arabidopsis*, and the 13-hydroxy pathway, respectively, produced GA₁ and GA₄. According to research by Hu *et al.* (2008), in *Arabidopsis*, GA₁ and GA₄ were deposited in flower buds, earlier-stage of silique (3 DAF), and in the mid-stage of seed development (about 9 DAF), respectively. (Figure 8). PsGA20oxs and PsGA3oxs were found by Nadeau *et al.* (2011) to be involved in the synthesis of bioactive Gas in growing pea seeds.

ABA Signalling

The four major genes in ABA signalling are protein phosphatase 2Cs (PP2Cs), pyrabactin resistance 1, pyrabactin-like/regulatory components of ABA receptors (PYR/PYL/RCAR), and SNF1-related protein kinase 2s (SnRK2s). According to Finkelstein (2013), When ABA is present, the ABA receptors PYR/PYL/RCAR form a complex with PP2C, reducing PP2C's phosphatase activity and, as a result, activating SnRK2. PP2Cs suppresses SnRK2 activities by dephosphorylating their kinase activation loops. According to Ng *et al.* (2014), The transcription of ABA-responsive genes is triggered by the active form of SnRK2, which also activates the ABRE-binding protein/ABRE-binding (AREB/ABF) transcription factors. In ABA signalling, the ubiquitinproteasome system (UPS) also plays a role. The UPS assures the repression of the ABA responses in the absence of ABA by degrading the ABA receptors PYR/PYL/RCAR, ABREB/ABF transcription factors, and SnRK2s.

GA Signalling

Griffiths (2006) opined that GA signalling in plants induced when bioactive GA is perceived by its receptor GIBBERELLIN INSENSITIVE DWARF1 (GID1). Sun (2011) studied that DELLA proteins are negative regulators of GA signalling. Murase *et al.* (2008) observed that when GA binds to GID1, the formation of the GA-GID1-DELLA complex is promoted, and the complex is associated with F-box protein, the central component of SCFSLY1/GID2 E3 ubiquitin ligase, which leads to DELLA degradation via the ubiquitin 26S proteasome pathway and as a result, GA response genes are activated.

➤ **Role of ABA and GA in Seed Development**

1) Function of GA and ABA in Embryogenesis:

Embryogenesis usually starts with a zygote of a single cell and ends after all of the embryo structures have been formed. The YUCCA (YUC) family of auxin biosynthesis genes and the LEAFY COTYLEDON genes (LEC1, LEC2, and FUSCA3) are among the critical genes for embryogenesis that have been discovered by Braybrook *et al.* (2008). Additionally, these LEAFY COTYLEDON genes are functional during the seed development stage. Generally, GAs are needed for appropriate seed development. Swain *et al.* (1997) studied that GAs are necessary for seed development has been provided by the analysis of GA-deficient mutant in pea. Singh *et al.* (2010) revealed that overexpression of the gene for GA2-oxidase (GA2ox) from pea in Arabidopsis seeds caused seed abortion and inhibition of growth, of pollen tube exhibiting that active GAs present in the endosperm are essential for normal seed development. The maternal tissues, especially the seed coat, play an important role in embryonic development [Liu *et al.*, 2015]. Robert *et al.* (2018) observed that the maternal tissues, especially the seed coat, play an important role in embryonic development. Kawashima *et al.* (2010) reported that the transport of nutrients and signals from the mother to embryo is essential for embryonic development and plant fertility. However, in plants, programmed cell death (PCD) causes the suspensor to degenerate at a relatively early stage of embryonic development [Yeung *et al.*, 1993]. In the study by Zhao *et al.* (2013) on *Nicotiana tabacum*, the antagonistic actions of two proteins—a protease inhibitor called cystatin NtCYS and its target, a cathepsin H-like protease called NtCP14—led to the establishment of the suspensor PCD. According to reports, the DELLA protein NtCRF (NtCYS regulative factor 1) controls NtCYS expression to control suspensor PCD in tobacco.

2) Gene Networks in the Maturation Phase :

Following the embryogenesis phase, the maturation phase begins. Transcription factors, a complex network regulates seed maturation. LAFL regulatory network is involved in this process. The LAFL genes include the AFL clade of B3 domain plant-specific transcription factors (ALF-B3), FUSCA3 (FUS3), ABA INSENSITIVE 3 (ABI3), LEAFY COTYLEDON 2 (LEC2) [Giraudat *et al.*, 1992], and the HAP3 subunit of the CCAAT-binding transcription factors (CBF or NF-Y), LEC1, and LEC1-LIKE (L1L) [Lotan *et al.*, 1998]. Genetic analysis shows that the LAFL genes organize a network with complex mutual interactions among LAFL genes (Figure 9). LEC1 can activate ABI3, FUS3, and LEC2 expression, while ectopic expression of LEC2 can up-regulate LEC1, ABI3, and FUS3 [Kagaya *et al.*, 2005]. ABI3 and

FUS3 positively regulate each other and their own expression [Monke *et al.*, 2012]. Moreover, L1L is regulated by FUS3 [Yamamoto *et al.*, 2010]. A recent ChIP analysis indicated that LEC1 regulates L1L [Junker *et al.*, 2012], whereas FUS3 regulates LEC1, FUS3, and ABI3 [Wang, *et al.*, 2013].

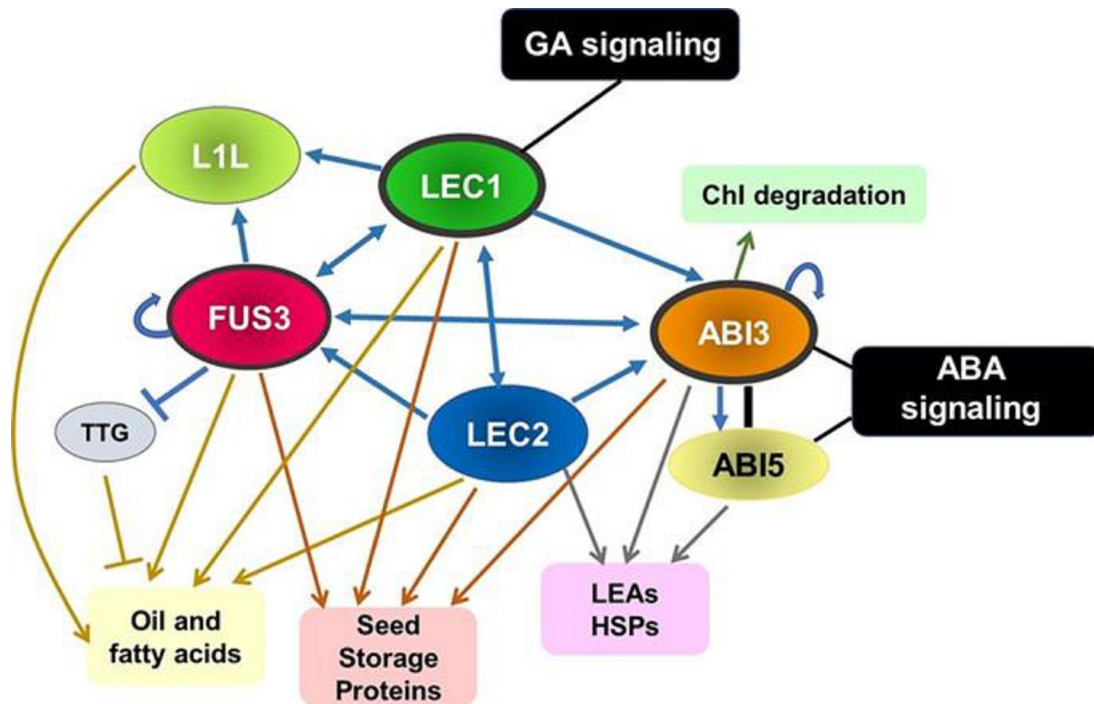

Figure-9: Molecular Aspects of Seed Development Controlled by Gibberellins and Abscisic Acids (Kozaki and Aoyanagi,2022).

LAF1 network regulates seed development. Arrows and blunted lines indicate activation and repression, respectively. Black line between ABI3 and ABI5 indicate the interaction of these proteins. LEC1, LEC2, and FUS3 (surrounded by the thick black line) are involved in acquisition of DT and all LAF1 proteins are involved in the regulation of dormancy. LEC1 is related to GA signalling and ABI3 and ABI5 are related to ABA signalling.

3) Accumulation of Seed Storage Products

Alonso-Blanco *et al* (2003) observed that ABA participates in the accumulation of seed storage components, including seed storage proteins (SSP), carbohydrates, and lipids, that are necessary for germination and early seedling growth and development. *PYL* and *SnRK2* mutations in ABA signalling frequently result in decreased seed storage products. [Nakashima *et al.*, 2009]. Zheng *et al.* (2010) revealed that inactivation of *SnRK2.6* results in reduction of seed oil content, while overexpression of *SnRK2.6* increases overall seed products. Several studies have revealed that the LAF1 genes are involved in the regulation of storage material accumulation. Zhang *et al.* (2016) observed that the production of anthocyanins, the accumulation of chlorophyll and lipid during maturation, and the accumulation of storage proteins (such as Cruciferin C and Arabidopsis 2S albumin storage protein 3 (*At2S3*)) are all regulated by LEC1 and FUS3 in an ABA-dependent manner. Various reports have proved that

Transparent Testa Glabra 1 (TTG1), which encodes a transcription factor that prevents the build-up of seed storage proteins and lipids in Arabidopsis, is negatively regulated by the protein FUS3. Chen *et al.* (2015) opined that FUS3 may lead to the accumulation of storage reserves by suppressing TTG1. Mendes *et al.* (2013) studied that other variables besides LAFL genes are also involved in the development of storage materials; bZIP67 controls FATTY ACID DESATURASE 3 (FAD3), which is in charge of storing omega-3 fatty acids throughout maturation, along with L1L and NUCLEAR FACTOR-YC2 (NF-YC2).

4) Desiccation Tolerance and De-Greening

Desiccation tolerance (DT) is a significant phenomenon that allows seeds to endure for extended periods of time before favourable germination circumstances are present. Holdsworth *et al.* (2008) studied that Chl loss during the DT process, also known as de-greening, is a common occurrence in many plants, and the presence of chl in developed seeds is viewed as an unfavourable trait that may influence seed development and quality. ABI3 was discovered to control STAY GREEN (SGR) gene expression in Arabidopsis to prevent embryo de-greening (AtSGR1 and AtSGR2). Roscoe *et al.* (2015) opined that the acquisition of DTs involves the essential functions played by LAFL genes. While a mutation in LEC2 does not have this effect, one in LEC1, ABI3, or FUS3 has a significant impact on DT, demonstrating that all three of these regulators are necessary to activate DT (Tou, *et al.*, 2006). A group of genes, including those that encode protective proteins like LEA (Delahaie *et al.*, 2013) and HEAT SHOCK PROTEINS (HSPs) [Wehmeyer *et al.*, 2000], as well as other protective enzymes, substances, and antioxidants, are necessary for the development of DT (Bailly, 2004).

5) Induction and Maintenance of Seed Dormancy:

After the completion of seed maturation, storage products are synthesised, dehydration starts, and de novo ABA is stored, and then seed dormancy is attained [Raz *et al.* 2001]. Importance of the ABA as a regulator in this process has been established by a number of pieces of evidence [Finch and Leubner 2006]. According to Nakashima *et al.* (2009), ABA production, sensing, and signalling mutations have an impact on seed dormancy. Two mutants of the Arabidopsis plant, AtNCED6 and AtNCED9, exhibit reduced ABA levels as well as dormancy in mature, dried seeds. Other ABA-deficient mutants, including as *aba1* and *aba2/3*, also exhibit reduced levels of dormancy [Leon-Kloosterziel *et al.*, 2006]. To induce primary seed dormancy in Arabidopsis, AtMYB96 directly activates ABA synthesis genes (AtNCED 2, 5, 6, and 9) and inactivates GA biosynthesis genes (AtGA3ox1 and AtGA20ox1). [Lee *et al.*, 2015]. Numerous observations suggest that LAFL gene members are crucial for the establishment of dormancy. According to West *et al.* (1994), the genes FUS3, LEC1, and LEC2 are in charge of regulating the growth arrest of embryos in mature seeds. All of these genes' mutants fail to completely stop embryo growth and show signs of early germination. According to Hoecker *et al.* (1991) the maize Viviparous 1 (Vp1) gene was one of the crucial ABA signalling elements that was first identified and characterised. A mutation in Vp1 causes pre-harvest sprouting and disrupts maize embryo maturation. According to research by Carrari *et al.* (2001), the Vp1 gene of rice, wheat, and

sorghum is likewise related to the degree of dormancy, susceptibility to ABA, and pre-harvest sprouting. According to Yamasaki *et al.* (2017), ABI5 is critical for the induction of dormancy during the maturation of wheat and pea seeds. Bentsink *et al.* (2006) reported that, REDUCED DORMANCY 5 (RDO5) and DOG1, two significant dormancy genes, seem to operate independently on ABA and other plant hormones. Seed dormancy is totally eliminated or diminished by mutations in DOG1 and RDO5, respectively (Xiang *et al.* 2014). The regulation of dormancy involves gene regulation networks in addition to other regulatory mechanisms such protein phosphorylation and chromatin remodelling. According to Wang *et al.* (2013), in order to alter the ABA signalling pathway and encourage seed dormancy, SIN3-like 1 (SNL1), a member of the Arabidopsis histone deacetylation complex, interacts with HDA19. Liu *et al.* (2007) revealed that the control of seed dormancy is mediated by a number of regulators, including HISTONE MONOUBIQUITINATION (HUB1: C3HC4-RING finger protein) and REDUCED DORMANCY 2 (RDO2: transcription elongation factor TFIIS).

Methods of Breaking Seed dormancy:

Seed dormancy can be broken by several ways, By A) Physical method (Scarification, microorganism's activity, natural forest fire, being eaten by animals etc.) and B) Physiological method (Stratification).

A. Physical method:

- Scarification is the process of breaking seed dormancy by reducing the restrictions brought on by the seed coat. (Ertekin, 2011; Kirdar and Ertekin,2008; Malavasi and Malavasi,2004; Rehman and Park, 2000).
- Scarification can be done in two ways – a) Mechanical scarification, and b) Chemical scarification.

a) Mechanical scarification:

- Mechanical scarification proved to be a very effective method for breaking seed dormancy. (Carvalho *et al.*, 1980).
- Mechanical scarification can be carried out in a number of ways, such as rubbing seeds between two pieces of sandpaper, applying an abrasive substance to the seed coat, applying sand, or vigorously shaking the seeds.
- Other methods for making seeds permeable to air and water include dipping seeds in hot water, heating and chilling them for a brief period of time, puncturing the seed coat with a needle, and exposing them to specific intermittent wavelengths. (Estaji *et al.*, 2012).

Dormancy types	Causes of dormancy	Conditions to break dormancy	Representative genera
1. Primary dormancy			
a. Exogenous dormancy	Influenced by external forces on the embryo		
Physical	Impermeable seed coat	Scarification	<i>Baptisia, Convolvulus, Gleditsia, Lupinus</i>
Chemical	Inhibitors in seed coverings	Removal of seed coverings (fruits) Leaching seeds	<i>Beta, Iris</i>
b. Endogenous dormancy	Imposed by factors in the embryo		
Morphological	The embryo is not fully developed at the time the seed sheds from the plant	Warm or cold stratification	
Rudimentary	Small undifferentiated embryo	Cold stratification and potassium nitrate	<i>Anemone, Ranunculus</i>
Linear	Small differentiated embryo <1/2 size of seed	Warm stratification and gibberellic acid	<i>Daucus, Cyclamen, Viburnum</i>
Physiological	Factors within embryo inhibits germination		
Nondeep	Positively photodormant (requires light) Negatively photodormant (inhibited by light) After-ripening	Red light Darkness Short period of dry storage	<i>Lactuca, Primula Cyclamen, Nigella Cucumis, Impatiens</i>
Intermediate	Embryo germinates if separated from the seedcoat Often responds to gibberellic acid	Moderate periods (up to 8 weeks) of cold stratification	<i>Aconitum, Cornus, Pinus</i>
Deep	Embryo does not germinate when removed from seedcoat or will form a physiological dwarf	Long periods (>8 weeks) of cold stratification	<i>Dictamnus, Euonymus, Prunus, Rhodotypos</i>
c. Combinational	Combinations of different dormancy conditions that must be satisfied sequentially		
Morphophysiological	Combination of underdeveloped or rudimentary embryo and physiological dormancy	Cycles of warm and cold stratification	<i>Asimina, Helleborus, Ilex, Magnolia, Mertensia</i>
Epicotyl	Radicle begins growth when temperature and water permit, but epicotyl is dormant	Warm followed by cold stratification	<i>Asarum, Paeonia</i>
Epicotyl and radicle (double dormancy)	Radicle and epicotyl require chilling stratification, but radicle is released during first year and then	Cold stratification followed by warm followed by a second cold stratification	<i>Convallaria, Trillium</i>
Exo-endodormancy	Combinations of exogenous and endogenous dormancy conditions. Example: physical (hard seedcoat) plus intermediate physiological dormancy	Sequential combinations of dormancy releasing treatments. Example: scarification followed by cold stratification	<i>Cercis, Tilia</i>
2. Secondary dormancy			
a. Thermodormancy	After primary dormancy is relieved, high temperature induces dormancy	Growth regulators or cold stratification	<i>Apium, Lactuca, Viola</i>
b. Conditional dormancy	Change in ability to germinate related to time of the year	Chilling stratification	Many species with endogenous dormancy display conditional dormancy

Fig-10: Seed dormancy categories (Hartmann *et al.*, 2002)



Fig-11: Mechanical scarification of dodder seeds with a handheld rotary tool. Katherine and Hilary (2012).

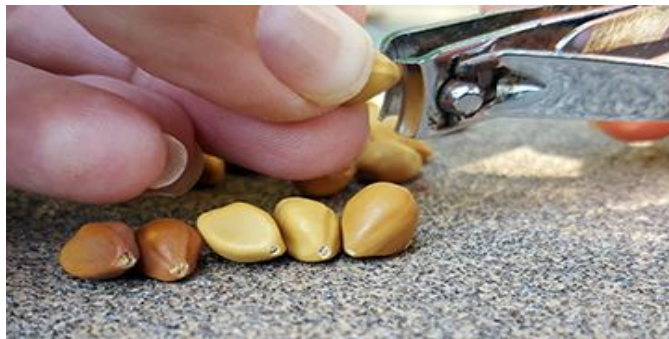

Fig-12: Scarification technique (Hilhorst *et al.* 1998)

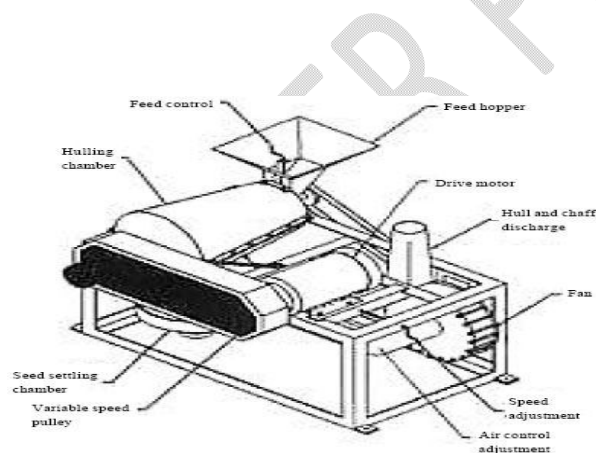

Fig-13: Techniques for scarifying seeds and their application to forage legumes (Kimura and Islam, 2012)

b.) Chemical scarification:

- Seed coat may be removed by treating with chemical materials.

- It is common practise to apply acid treatments to seed coats, especially thick impermeable seed coats. The temperature of the acid and the duration of time the seeds are soaked in concentrated sulfuric acid (H_2SO_4) are key considerations. (Machhia *et al*, 2001).
- Before the acid penetrates the seed coverings, the seeds must be taken out from the solution. (Mabundza and Wahome, 2010).
- The seeds must be quickly removed and carefully cleaned to neutralize the remaining acid completely.
- Cellulase and pectinase, two specific enzymes found in the seed coat, are used in several recently discovered procedures to remove the seed coat.
- Additionally, to break seed dormancy, chemical solvents like alcohol and acetone are used. (Mousavi *et al*, 2011).

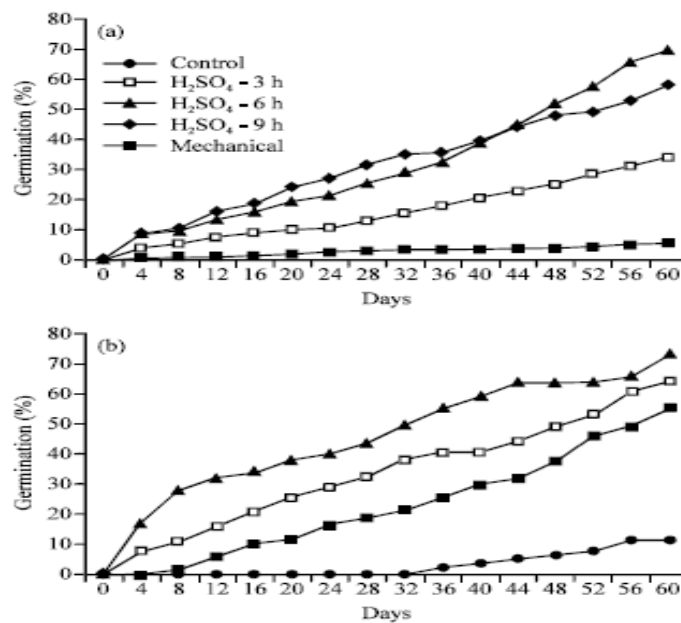

Fig -14: Effects of Seed Scarification on Seed Germination and Early Growth of Olive Seedlings. (Rostamiand Shasavar, 2009.)

Effects of mechanical and chemical scarification treatments on germination rate of olive cultivars (a) Cultivar Arbequina and (b) Cultivar Koronaiki. Control and mechanical scarification treatments are equal in Arbequina. Sulphuric acid treatment for 9 h acid treatment of Koronaiki, did not germinate.

c) Bio scarification:

- Seed dormancy may be overcome by making use of animals, insects and Micro-organism in order to breakdown the seed coat impermeability.
- It is done to partially damage the hard seed coat to overcome physical dormancy and allows to imbibition of water on part or entire seed surface leading to metabolic process of germination.

o Animals:

- Evenari (1949) studied those germination inhibitors that can disrupt germination biochemical pathways are frequently found in fruit pulp.
- Droppings of animals help to soften the hard seed coat. Combination of moisture, warmth, and chemical reaction by digestive juices soften the hard seed coat and make them become permeable (Robertson *et al.* 2006; Samuels and Levi, 2005; Murray *et al.*, 1994).
- **Insect:**
 - Breaking seed dormancy involves using of insects, most commonly termites.
 - Karban and Lowenberg (1992) noted that, feeding by seed bugs and weevils increased germination of wild *Gossypium* species.
- **Microorganisms:**
 - Morpeth and Hall (2000) reported that microorganisms that may aid in breaking dormancy interact with seeds in the soil.
 - They observed that, in seeds with physiological dormancy, fungi can potentially reduce mechanical barrier to germination by growing on the testa and shattering the hard, stony endocarp.
- d) **Applying of Fire:**
 - It is a method of subjecting the dormant seeds to heat generated by fire.
 - It is done to partially damage the hard seed coat to overcome physical dormancy to allow imbibition of water over the entire seed surface, leading to the metabolic process of germination.
 - Keeley (1991 and 1995) observed that, the heat shock caused by wildfires has been shown to break seed dormancy and trigger germination in many species with physical dormancy (heat accelerated germination), especially in fabaceae and cistaceae in Mediterranean fire-prone habitats.
 - Moreira *et al.* (2011) and Bell *et al.* (1993) obtained similar kind of experiment, and made a conclusion that heat-shock treatment enhances the chances of breaking seed dormancy and increase the germination rate in *fabaceae* and *cistaceae* species.
 - Zirondi *et al.* (2019) further revealed that, not only fire, but also smoke accompanies fire showed to induce germination.

B. Physiological method:

a. Stratification:

It is a physiological method where the imbibed seeds are exposed to lower temperature (cold stratification) or higher temperature (warm stratification) for a period of time.

i) Cold stratification:

- Seeds are soaked in water before exposing them upto pre-chilling temperature for certain period of time specific for several species.
- Hartmann *et al.* (1997) reported that most temperate plants and shrubs' dry seeds must be ingested to a threshold moisture content under cold temperatures (0–5 C) before they will germinate and thrive (cold stratification).

- Martinez and Dicenta (2001) studied that, for *Prunus persica* cv. GF305, chilling is crucial in supplying the stimulation necessary to break dormancy, boost germination, and produce normal seedlings.
- Jensen and Eriksen (2001), and Karam and Al-Salem (2001) made similar kind of observation in strawberry tree and sweet cherry tree (*Prunus avium*) respectively.

ii) Warm stratification:

- Baskin and Baskin (2004) reported that Warm stratification is necessary for embryo growth and radicle emergence in seeds with undeveloped embryos in order for them to germinate (i.e., to break dormancy).
- Nikolaeva *et al.* (1985) studied that Seeds of *P. ofcinalis* had physiological dormancy, require warm stratification for the loss of Physiological dormancy, and this was occurred during summer.
- Deep simple epicotyl morpho-physiological dormancy was observed in seeds of *P. corsica* (Porceddu *et al.* 2015), *P. spontanea* (Jing and Zheng 1999) and to break this kind of dormancy requires warm stratification for the loss of physiological dormancy of the root.

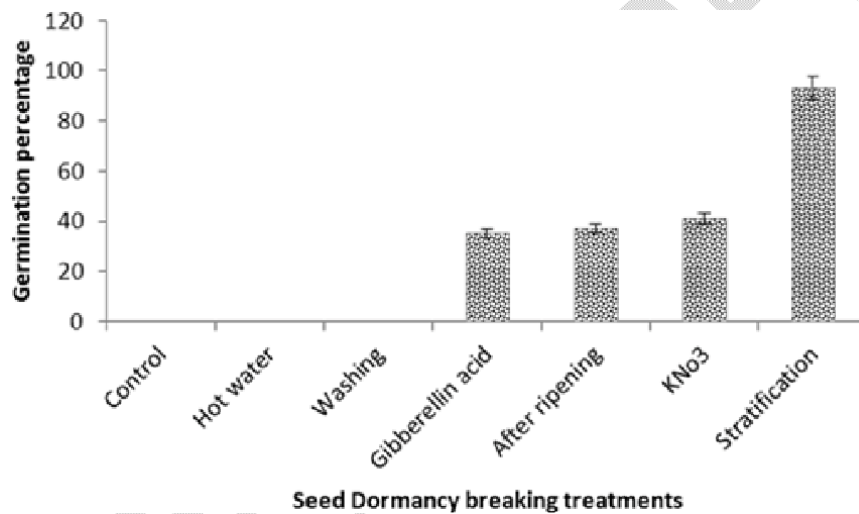

Fig-15: Evaluation of different techniques for breaking dormancy. (Ashgar and Shabnam, 2013).

b) Chemical method:

○ **Soaking in chemicals:**

i) Soaking in KNO₃:

- Previero *et al.* (1996) reported that KNO₃ was quite successful in bringing several species out of dormancy.
- According to Yucel (2000), it is a chemical that controls growth in *Salvia* species. It was also noted that sunflower seed dormancy was broken by 1% potassium nitrate.
- Borghetti *et al.* (2002) also noted similar type of successful seedling emergence observation. Maiti *et al.* (2006) estimated breaking seed dormancy in sunflower by using potassium nitrate.

ii) Thiourea:

- According to Hosseini *et al.* (2011), exogenous use of thiourea provides a practical and secure way for preventing potato minituber dormancy.
- Chang and Sung (2000) reported that Seed and bud dormancy can be broken by thiourea either naturally or by environmental factors. Similar kind of observation was reported by El-Keblawy (2013).

iii) Hydrogen peroxide:

- Kindiger (1994) studied the germination enhancement by incubation in H₂O₂.
- Wang *et al.* (1998) studied the promotion of barley caryopsis germination by this oxidant compound which was related to reduction of ABA content.
- Benech *et al.* (2006) reported that hypoxia conditions not only interfere with ABA degradation but also increased ABA sensitivity of barley embryos.
- Grange *et al.* (2003) observed germination increments in H₂O₂-treated seeds of different species.
- Matuz-Cadiz and Hucl (2005) proposed different mechanisms to explain the promoting effect of hydrogen peroxide on germination.

o Soaking in growth regulators:

i) Gibberellic acid and Kinetin:

- Dweikat and Lyrene, (1988) evaluated that numerous seed species such as *Lonicera Japonica*, *Lonicera maackii* had been observed to emerge from dormancy when treated with exogenous growth regulators such as gibberellins (often gibberellic acid GA₃ and GA₄) and cytokinins (typically kinetin, benzyl adenine).
- Mehanna *et al.* (1985), Karam and Al-Salem, (2001) and Mukherjee *et al.* (2022) conducted similar kind of experiment.
- Chauhan *et al.* (2006), Rogis *et al.* (2004), Ray and Bordolui (2022) and Gashi *et al.* (2012) studied that hormones—including gibberellic acid (GA₃)—are the most often used compounds to hasten the breaking of dormancy.
- According to Tang *et al.* (2012), exogenous GA₃ treatments increased the germination of meadow foxtail and annual bluegrass (*Poa annua*) (*Alopecurus aequalis*); Biswas *et al.* (2021) in China aster (*Callistephus chinensis* L.), Biswas *et al.* (2020) in rice.

ii) Ethylene:

- By breaking seed dormancy, ethylene has been shown to promote germination. It promotes the germination of dormant and non-dormant seed by releasing ethephon.
- The effect of ethylene in the release of primary and secondary dormancy and the germination of non-dormant seeds under normal and stressful conditions was investigated by Kpczyriska and Kaczynski (1997).
- Ketring and Morgan (1971) observed that ethylene or ethephon removes primary seed dormancy in peanut.
- Ketring and Morgan (1972) made a conclusion that exogenous ethylene or ethephon - an ethylene-releasing compound - stimulates seed germination.

- Similar kind of observation was observed by Kepczynski and Rudnicki (1977) in apple and Corbineau and come (1990) in sunflower.
- Esashi and Leopold (1969) made a conclusion that Ethylene or Ethephon also breaks secondary dormancy in the seeds of cocklebur.

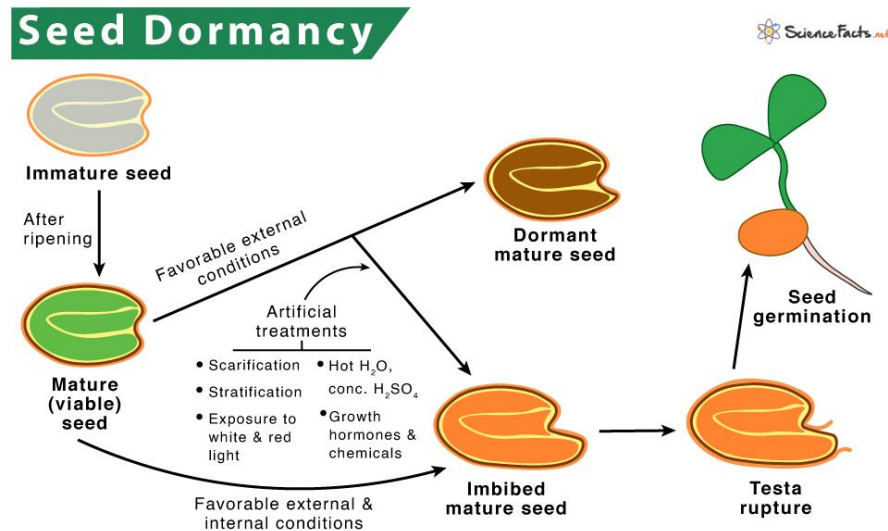

Fig-16: Seed dormancy and the control of germination. (William *et al.*, 2006).

List 1 : Various dormancy breaking methods applied in several crop:

Crop name	Method of breaking dormancy	Name of Author(s)	Year
Rice	Seed dormancy was broken using dry heat treatments: 45 °C for 7 days	Watanabe <i>et al.</i>	1998
	High humidity successfully disrupted seed dormancy: 45 °C for 1-3 days.	Hoshina and Urano	2010
	Rice seed treatments with hot water at 60 °C for 10 minute effectively increased germination rate, respiration rate, ethylene generation, and -amylase activity.	Fukuda <i>et al.</i>	2013
Sorghum	By prechilling (cold stratification) the sorghum samples for six days at 5° C, dormancy was broken.	Robbins and Porter	2013
	Dormancy might be broken with a hot water treatment that involved immersing the seed	Goodsell	1997

	for four minutes in water at 70° C.		
	Chemical treatment enhanced germination to 94% when seeds were soaked in 0.5, 1.0, and 1.5% KNO ₃ for 2 hours.	Shanmugavalli <i>et al.</i>	2007
Maize	Soaking in gibberellic acid solution (1000mg /lit) for 24 hrs can to break dormancy in teosinte.	William <i>et al.</i>	2004
	20% hydrogen peroxide (H ₂ O ₂) for 24 hrs can be beneficial in breaking dormancy and further increase in germination.	Taba <i>et al.</i>	2006
Wheat	Seeds kept in 26 ° C for 15 days showed no dormancy.	Reddy <i>et al.</i>	1987
Sunflower	Exogenous ethylene application (50ppm) for 7 days strongly stimulated germination at 15°C of freshly harvested ripe sunflower achenes.	Corbineau.	1987
	Gibberellic acid (GA ₃) in a 1 mM solution was used to chemically pre-treat wild sunflower achenes, nearly doubling the germination rate.	Singh and Rao	1994
	dry heating of sunflower seed at 80°C for 10 minutes helps to remove dormancy and increase in germination	Pallavi <i>et al.</i>	2010
Mustard	for reduction of wild mustard seed dormancy and improve its germination was 24 hours of soaking in gibberellic acid @1500 ppm.	Hosseini and Reza	2014
Soybean	Hydrogen peroxide (H ₂ O ₂) and ethylene treatment aids in overcoming the soybean seed coat's resistance and increases the germination rate.	Ishibashi <i>et al.</i>	2013
	The best way to break dormancy was five minutes of immersion in H ₂ SO ₄ (98%) followed by rinsing in water because it produced the highest percentage of germination.	Morais <i>et al.</i>	2014
Groundnut	1% Ethrel applied to dry seeds is a convenient and effective preplanting seed treatment for breaking dormancy of dormant peanut seeds	Ketring and Morgan	1999

	under controlled conditions or in the field.		
Sesame	Sesame seeds' dormancy was broken by GA3, and lower doses (500 ppm) produced better results than higher ones (1000 ppm).	Ashri and Palevitch	1998
Carrot	Breaking dormancy and boosting the germination rate were both greatly aided by soaking carrot seeds for three hours in 100 ppm of GA3.	Aki	2000
	Applying of acetylsalicylic acid, 100 mg L ⁻¹ for 24 hrs was effective for carrot seed in overcoming dormancy and advancing in germination at 5°C.	Rajasekaran	2001
Onion	20% (weight by volume) hydrogen peroxide applied exogenously for 2 to 4 hours was very successful in releasing onion bulb endodormancy.	Christopher and Goldman.	2019
Okra	Okra farmers can use 80% H ₂ SO ₄ for 3 minutes to break dormancy, though dry heating for 5 minutes at 70°C and soaking for 12 hours at 30°C are other effective options.	Musara <i>et al.</i>	2015
Potato	Application of 5-10 ppm GA3 to treat all types of tubers, and further Soaking of tubers in a 1 % aqueous solution of thiourea for one hour after treatment, or cold shock plus heat treatment at 4 °C and then held potato tubers at 18-25 ° C for two or more weeks, could help to break dormancy.	Bryan	2009
Red gram	Hot water and hot air oven treatment could help for breaking hardseededness.	Borikar <i>et al.</i>	1985
Gram	For breaking the strong seed coat dormancy in Gram, intense sulfuric acid treatment for 60 seconds has been proven to be more effective.	Lambat <i>et al.</i>	2017
Locust bean (<i>Parkia biglobosa</i>)	Seeds immersed in concentrated H ₂ SO ₄ exhibited the second-fastest rate of germination after mechanical scarification with sandpaper.	Okunala <i>et al.</i>	2011
Garlic	The seed dormancy time is shortened from 5 to 6 months to 12 weeks using thermal sock procedures, which combine storage at high	Sasmitaloka <i>et al.</i>	2021

	temperatures (38 to 42°C) for 6 weeks and low temperatures (12 to 14°C) for 6 weeks (for a total of 12 weeks).		
Jute	Mechanical scarification with rubbing the seeds with sandpaper for 3 minutes found to be most effective method.	Maina <i>et al.</i>	2011

Conclusion:

Dormancy in seeds can occur at different phases of seed development, therefore classifying dormancy would make it easier for seed experts to comprehend their findings. Additionally, by adapting the dormancy breaking techniques used in many crops and it can inspire biochemists and molecular biologists who are researching on seed dormancy and ways to break it. Dormancy and germination are extremely complex features regulated by a number of genes. Recent years have seen a sharp rise in the number of mutations and genes involved. These investigations validated the pivotal function of plant hormones. In particular, ABA and GA are crucial for seed growth and germination. Most attention has been paid to the functions of these hormones in the induction, maintenance, and breaking of dormancy and germination. The role of ABA and GA in the various stages of seed development has also been highlighted in this review. Various dormancy breaking methods applied in several crop could also help researcher to further study the dormancy pattern and breaking of it on that particular crop.

References

- Afzal I, Mukhtar K, Qasim M, Basra S, Shahid M, Haq Z. Magnetic stimulation of marigold seed. *International Agrophysics*. 2012; 26: 335-339.
- Aki S. Effect of gibberellin on breaking dormancy of kintoki carrot seeds. *Kagawa*. 2000;12:73.
- Alonso-Blanco C, Bentsink L, Hanhart CJ, Vries HB, Koornneef M. Analysis of Natural Allelic Variation at Seed Dormancy Loci of *Arabidopsis thaliana*. *Genetics*. 2003;164: 711-729.
- Asghar A, Darabinejad S. Evaluation of different techniques for breaking seed dormancy of *Heliotropium europaeum*. *Journal of Biological and Environmental Sciences*. 2013;7:87-91.
- Ashri A, Palevitch D. Seed Dormancy in Sesame (*S. indicum*) and the effect of Gibberellic acid. *Experimental Agriculture*. 1998; 15(1): 81-83.
- Atwater BR. Germination, dormancy and morphology of the seeds of herbaceous ornamental plants. *Seed sci.Technol*. 1980;8: 523-573.
- Babiker AGT, Ma YQ, Sugimoto Y, Inanaga S. Conditioning period, CO₂ and GR24 influence ethylene biosynthesis and germination of *Striga hermonthica*. *Physiologia Plantarum*. 2000;109: 75-80.
- Bailly C. Active oxygen species and antioxidants in seed biology. *Seed Sci. Res*. 2004;14: 93-107.
- Baskin JM, Baskin CC, Li X. Taxonomy, anatomy and evolution of physical dormancy in seeds. *Plant species Biol*. 2000;15:139-152.
- Baskin JM, Baskin CC. A classification system for seed dormancy. *Seed Sci Res*. 2004;14(1): 1-16.

- Beaudoin N, Serizet C, Gosti F, Giraudat J. Interactions between abscisic acid and ethylene signalling cascades. *Plant Cell*. 2000;12: 1103-1115.
- Bell D, Plummer J, Taylor S. Seed germination ecology in south-western Western Australia. *The Botanical Review*. 1993;59: 24-73.
- Benech RL, Gualano N, Leymarie J, Come D, Corbineau F. Hypoxia interferes with ABA metabolism and increases ABA sensitivity in embryos of dormant barley grains. *Journal of Experimental Botany*. 2006;57: 1423-1430.
- Bentsink L, Koornneef M. Seed Dormancy and Germination. *American Society of Plant Biologists*. 2008;97:1-18.
- Bentsink, L., Jowett, J., Hanhart, C.J. and Koornneef, M. (2006). Cloning of DOG1, a quantitative trait locus controlling seed dormancy in Arabidopsis. *Proc. Natl. Acad. Sci.*2006; 103: 17042-17047.
- Bewley JD. Seed germination and dormancy. *Plant Cell*. 1997;9 (7): 1055-1066.
- Biswas S, Bordolui SK, Chattopadhyay P. Influence of GA₃ on hybrid rice seed production in West Bengal. *J. of Crop and Weed*. 2020; 16(3): 136-142 DOI : <https://doi.org/10.22271/09746315.2020.v16.i3.1378>
- Biswas S, Bordolui SK, Sadhukhan R. Response of China Aster (*Callistephus chinensis* L.) genotypes towards foliar application of GA₃. *American International Journal of Agricultural Studies*. 2021; 5(1), 1–15. <https://doi.org/10.46545/aijas.v5i1.197>
- Borghetti F, Noda FN, De Sa CM. Possible involvement of proteasome activity in ethylene-induced germination of dormant sunflower embryos. *Brazilian J. Plant Physiol*. 2002;14: 125-131.
- Borikar ST, Singh A R, Katkade JL. Effect of pre-treatment of green gram (*Vigna radiata*) seed with certain chemicals on its germination. *Seed Res*. 1985;13(1): 192-194.
- Braybrook SA, Harada JJ. LECs go crazy in embryo development. *Plant Sci*. 2008;13: 624-630.
- Bryan J. Breaking dormancy of potato tubers. *La Molina*.2009;16: 1-14.
- Carrari F, Perez-Flores L, Lijavetzky D, Enciso S, Sanchez R, Benech-Arnold R, Iusem N. Cloning and expression of a sorghum gene with homology to maize vp1. *Plant Mol. Biol*. 2001;45: 631-640.
- Carvalho NM, Filho JFS, Graziano TT, Aguiar IB. Maturação fisiológica de sementes de amendoim-do-campo. *Revista Brasileira de Sementes*. 1980;2: (2): 23-27.
- Chang YS, Sung FH. Effects of gibberellic acid and dormancy breaking chemicals on flower development of *Rhododendron pulchrum* sweet and *Rhododendron scabrum*. *Don. Sci. Hort*. 2000;83: 331-337.
- Chauhan BS, Gill G, Preston, C. Influence of environmental factors on seed germination and seedling emergence of Oriental mustard (*Sisymbrium orientale*). *Weed Sci*. 2006;6: 1025-1031.
- Chen M, Zhang B, Li C, Kulaveerasingam H, Chew FT, Yu H. TRANSPARENT TESTA GLABRA1 regulates the accumulation of seed storage reserves in Arabidopsis. *Plant Physiol*. 2015;169: 391-402.
- Chono M, Matsunaka H, Seki M, Fujita M, Kiribuchi-Otob C, Oda S, Kojima H, Kobayashi D, Kawakami N. Isolation of a wheat (*Triticum aestivum* L.) mutant in ABA 80-hydroxylase

- gene: Effect of reduced ABA catabolism on germination inhibition under field condition. *Breed. Sci.* 2013;63: 104-115.
- Christopher J, Goldman I. Breaking Onion bulb endo-dormancy with hydrogen peroxide. *American journal of horticultural sciences.*2019;54:10.
- Cohn MA, Butera DL. Seed dormancy in red rice (*Oryza sativa*): Response to cytokinins. *Weed Science.* 1982;30: 200-205.
- Considine L, Bentsink L, Maarten K. On the Language and Physiology of dormancy and quiescence in plants. *Academic press.*2016;39:48-52.
- Corbineau F, Bagniol S, Come D. Sunflower (*Helianthus annuus* L.) seed dormancy and its regulation by ethylene. *Israel Journal of Botany.* 1990;39: 313-325.
- Crocker. Mechanics of dormancy in seeds. *Amer. J. Bot.* 1916;3: 99-120.
- Delahaie J, Hundertmark M, Bove J, Leprince O, Rogniaux H, Buitink J. LEA polypeptide profiling of recalcitrant and orthodox legume seeds reveals ABI3-regulated LEA protein abundance linked to desiccation tolerance. *J. Exp. Bot.* 2013;64: 4559-4573.
- Dweikat IM, Lyrene PM. Response of highbush blueberry seed germination to gibberellin and 6*N*-benzyladenine. *Canadian Journal of Botany.* 1988;67: 3391-3393.
- El-Keblawy A. mpacts of dormancy-regulating chemicals on innate and salinity-induced dormancy of four forage grasses native to Arabian deserts. *Grass Forage Sci.* 2013;68: 288–296.
- Ertekin M. Effects of microorganisms, hormone treatment and stratification on seed. *Seed Technol.* 2011;17:18-21.
- Esashi Y. Ethylene and seed germination. *The plant hormone ethylene.* 1991;49: 89-94.
- Esashi Y, Leopold AC. Dormancy regulation in subterranean clover seeds by ethylene. *Plant Physiol.* 1969;44:1470-1472.
- Estaji A, Hosseini, B, Dehghan E, Pirzad A. Seed treatments to overcome dormancy of Nuruzak (*Salvia lerifolia*). *International Research Journal of Applied and Basic Science.* 2012;3 (10): 2003-2008.
- Evenari M. Germination inhibitors. *Botanical Review.* 1949;15: 153-194.
- Fabian B, Nakamura NF, Cezar M. Possible involvement of protease activity in ethylene induced germination of dormant sunflower embryos. *Brazilian Journal of Plant Physiology.* 2002;14: 125-131.
- Fidler J, Zdunek-Zastocka E, Prabucka B, Bielawski W. Abscisic acid content and the expression of genes related to its metabolism during maturation of triticale grains of cultivars differing in pre-harvest sprouting susceptibility. *J. Plant Physiol.* 2016;207: 1-9.
- Finch-Savage WE, Leubner-Metzger G. Seed dormancy and the control of germination. *New Phytol.* 2006;171: 501-523.
- Finkelstein R. Abscisic Acid synthesis and response. *Arab. Book.* 2013;11: 166.
- Finkelstein RR, Gampala SSL, Rock CD. Abscisic acid signalling in seeds and seedlings. *Plant Cell.* 2002;14: 515-545.
- Frey A, Godin B, Bonnet M, Sotta B, Marion-Poll A. Maternal synthesis of abscisic acid controls seed development and yield in *Nicotiana plumbaginifolia*. *Planta.* 2004; 218: 958-964.

- Gao F, Ayele BT. Functional genomics of seed dormancy in wheat: advances and prospects. *Plant Sci.* 2014;5: 458.
- Gao SP, Fan B, Liu GX, Kong XS, Yang Z, Pei J, Hang XY. Primary study on effect of epicotyls-dormancy breaking of seeds of herbaceous peony and tree peony. *North Horticul.* 2008;5:116-118.
- Gashi B, Abdullai K, Mata V, Kongjika E. Effect of gibberellic acid and potassium nitrate on seed germination of the resurrection plants *Ramonda serbica* and *Ramonda nathaliae*. *Afr. J. Biotech.* 2012;11: 4537-4542.
- Geneve RL. Seed dormancy in commercial vegetable and flower seeds. *Seed Technol.* 1998;20:236-250.
- Ghassemian M, Nambara E, Cutler S, Kawaide H, Kamiya Y, McCourt P. Regulation of abscisic acid signalling by the ethylene response pathway in *Arabidopsis*. *Plant Cell.* 2000;12: 1117-1126.
- Giraudat J, Hauge BM, Valon C, Smalle J, Parcy F, Goodman HM. Isolation of the *Arabidopsis* ABI3 gene by positional cloning. *Plant Cell.* 1992;4: 1251-1261.
- Goldberg RB, Paiva G, Yadegari R. Plant embryogenesis: zygote to seed. *Science.* 1994;266: 605-614.
- Goodsell SF. Germination of dormant sorghum seed. *Agron.* 1997;49:387-389.
- Grange S, Leskovar DI, Pik, LM, Cobb BG. Seed coat structure and oxygen enhanced environments affect germination of triploids watermelon. *Journal American Society Horticultural Sciences.* 2003;128: 253-259.
- Green JG, Helgeson EA. The effect of gibberellic acid on dormant seed of wild oat. *Weed Control.* 1957;14: 39-40.
- Griffiths J, Murase K, Rieu I, Zentella R, Zhang ZL, Powers SJ, Gong F, Phillips AL, Hedden P, Sun T. Genetic Characterization and Functional Analysis of the *GID1* Gibberellin Receptors in *Arabidopsis*. *Plant Cell.* 2006;18: 3399-3414.
- Groot SPC, Karssen CM. Gibberellins regulate seed germination in tomato by endosperm weakening: A study with gibberellin-deficient mutants. *Planta.* 1987;171: 525-531.
- Harper JL. The ecological significance of dormancy and its importance in weed control. *Proceedings of the international congress on crop protection.* 1957;4: 415-420.
- Hartman HT, Kester DE, Davies FT, Genève RL. Plant propagation: Principles and practices. *Journal of Range Management.* 1997;33: 115-118.
- Hayashi M. Physiological studies on the relationship between levels of the endogenous germination inhibitors and the dormancy of rice seed. *Bulletin of the Faculty of Agriculture, Kagoshima University.* 1986; 36:1-43.
- Hilhorst HWM. A critical update on seed dormancy. *Seed Science Research.* 1995 5: 61- 73.
- Hilhorst HWM. The regulation of secondary dormancy. The membrane hypothesis revisited. *Seed Science Research.* 1998;8: 77-90.
- Hoecker U, Vasil IK, McCarty DR. Integrated control of seed maturation and germination programs by activator and repressor functions of *Viviparous-1* of maize. *Genes Dev.* 1995;9: 2459-2469.
- Holdsworth MJ, Bentsink L, Soppe WJJ. Molecular networks regulating *Arabidopsis* seed maturation, after-ripening, dormancy and germination. *New Phytol.* 2008;179: 33-54.

- Homrichhausen TM, Hewitt JR, Nonogaki H. Endo-b-mannanase activity is associated with the completion of embryogenesis in imbibed carrot (*Daucus carota* L.) seeds. *Seed Science Research*. 2003;13: 219-227.
- Hoshina T, Urano K. Growth, yield and germination characteristics of super-high-yielding rice varieties. *Report of the Chugoku Branch of the Crop Science Society of Japan*. 2010;51: 21–22.
- Hosseini R, Jafar A, Reza E. Investigation of Prechilling and Scarification (Chemical and Physical) Treatments in breaking of Wild Mustard (*Sinapis Arvensis*) seed dormancy. *Iranian journal of seed science and technology*. 2014;2(2): 147-159.
- Hosseini MB, Afshari RT, Salimi K. Breaking dormancy of potato minitubers with thiourea. *Potato J*. 2011;38 (1): 9-12.
- Hu J, Mitchum MG, Barnaby N, Ayele BT, Ogawa M, Nam E, Lai WC, Hanada A, Alonso JM, Ecker JR. Potential Sites of Bioactive Gibberellin Production during Reproductive Growth in Arabidopsis. *Plant Cell*. 2008;20: 320-336.
- Hu Y, Zhou L, Huang M, He X, Yang Y, Liu X, Li Y, Hou X. Gibberellins play an essential role in late embryogenesis of Arabidopsis. *Nat. Plants*. 2018;4: 289-298.
- Ishibashi Y, Koda Y, Zheng SH, Yuasa T, IwayaInoue M. Regulation of soybean seed germination through ethylene production in response to reactive oxygen species. *Annals of Botany*, 2013;111: 95-102.
- Jensen M, Eriksen EN. Development of primary dormancy in seeds of *Prunus avium* during maturation. *Seed Science and Technology*. 2001;29: 307–320.
- Jing XM, Zheng GH. The characteristics in seed germination and dormancy of four wild species of tree peonies and their bearing on endangerment. *Acta Phytophysiol*. 1999;25:214–221.
- Junker A, Monke G, Rutten T, Keilwagen J, Seifert M, Thi, TM, Renou JP, Balzergue S, Viehover P, Hahnel U. Elongation-related functions of LEAFY COTYLEDON1 during the development of Arabidopsis thaliana. *Plant J*. 2012; 71: 427-442.
- Kagaya Y, Okuda R, Ban A, Toyoshima R, Tsutsumida K, Usui H, Yamamoto A, Hattori T. Indirect ABA-dependent regulation of seed storage protein genes by FUSCA3 transcription factor in Arabidopsis. *Plant Cell Physiol*. 2005;46: 300-311.
- Kanno Y, Jikumaru Y, Hanada A, Nambara E, Abrams SR, Kamiya Y, Seo M. Comprehensive hormone profiling in developing Arabidopsis seeds: Examination of the site of ABA biosynthesis, ABA transport and hormone interactions. *Plant Cell Physiol*. 2010;51: 1988-2001.
- Kapur A, Kaur J, Sharma H L. Rice grain dormancy and its alleviation. *Crop Science*. 1987;4: 530–533.
- Karam NS, Al-Salem MM. Breaking dormancy in Arbutus and rachna L. seeds by stratification and gibberellic acid. *Seed Science and Technology*. 2001;29: 51–56.
- Karban R, Lowenberg G. Feeding by seed bugs and weevils enhances germination of wild *gossypium* species. *Oecologia*. 1992;92: 196-200.
- Katherine M, Hilary A. Mechanical scarification of dodder seeds with a handheld rotary tool. *Weed Technology*. 2012;26(3):485-489.
- Kawashima T, Goldberg RB. The suspensor: Not just suspending the embryo. *Trends Plant Sci*. 2010;15: 23 -30.

- Kebreab E, Murdoch A. A quantitative model for loss of primary dormancy and induction of secondary dormancy in imbibed seeds of *Orobancha spp.* *Journal of Experimental Botany.* 1997;50: 211-219.
- Keeley JE. Seed germination and life history syndromes in the California chaparral. *The Botanical Review.* 1991;57: 81-116.
- Keeley JE. Seed germination patterns in fire-prone Mediterranean-climate regions. Academic Press. 1995;17: 239–273.
- Kepczyjski J, Rudnicki RM, Khan AA. Ethylene requirement for germination of partly after-ripened apple embryo. *Physiol Plant.* 1977;40:292–295.
- Kermode RA. Role of abscisic acid in seed dormancy. *J. Plant. Growth Regul.* 2005;24:122-125.
- Ketring D L, Morgan PW. Ethylene as a component of the emanations from germinating peanut seeds and its effect on dormant Virginia-type seeds. *Plant Physiol.* 1999;44:326-330.
- Ketring DL, Morgan PW. Physiology of oil seeds II. Dormancy release in Virginia-type peanut seeds by plant growth regulators. *Plant Physiol.* 1971;47:488–492.
- Ketring DL, Morgan PW. Physiology of oil seeds. IV. Role of endogenous ethylene and inhibitory regulators during natural and induced after ripening of dormant Virginia-type peanut seeds. *Plant Physiol.* 1972;50:382-387.
- Kgpczynski J, Kpczyriska E. Ethylene in seed dormancy and germination. *Physiol. Plant.* 1997;101:120-126.
- Kimura E, Islam ME. Seed scarification and their use in forage legumes. *Research journal of seed sciences.* 2012;5(2):38-50.
- Kindiger B. A method to enhance germination of eastern Gama grass. *Maydica.* 1994;39: 53-56.
- Kirdar E, Ertekin M. The role of polystimulin hormone application and stratification temperature to break the dormancy and improve seed germination for *Abies nordmanniana* (Stev.) Spach. *Seed Science and Technology.* 2008;36: 301-310.
- Koide T, Ogino I, Shaku I. Applying the accelerated aging treatment to break seed dormancy of rice. *Research bulletin of the Aichi-ken Agricultural Research Centre.* 1988;20: 77-82.
- Kozaki A, Aoyanagi T. Molecular Aspects of Seed Development Controlled by Gibberellins and Abscisic Acids. *Int. J. Mol. Sci.* 2022;23:1876.
- Lambat A, Lambat P, Babhulkar V, Gadewar R, Charjan R, Parate R. The effect of stratification and scarification on germinability of black gram seeds. *International journal of researches in biosciences.* 2017;5(1):26-27.
- Lee HG, Lee K, Seo PJ. The Arabidopsis MYB96 transcription factor plays a role in seed dormancy. *Plant Mol. Biol.* 2015;87: 371-381.
- Lefebvre V, North H, Frey A, Sotta B, Seo M, Okamoto M, Nambara E, Marion-Poll A. Functional analysis of Arabidopsis NCED6 and NCED9 genes indicates that ABA synthesized in the endosperm is involved in the induction of seed dormancy. *Plant J.* 2006;45: 309-319.
- Leon-Kloosterziel KM, Gil MA, Ruijs GJ, Jacobsen SE, Olszewski NE, Schwartz SH, Zeevaart JAD, Koornneef M. Isolation and characterization of abscisic acid-deficient Arabidopsis mutants at two new loci. *Plant J.* 1996;10: 655-661.
- Leubner-Metzger G. Brassinosteroids and gibberellins promote tobacco seed germination by distinct pathways. *Planta.* 2001;213: 758-763.

- Leubner-Metzger, Petruzzelli L, Waldvogel R, Vogeli-Lange R, Meins F. Ethylene-responsive element binding protein (EREBP) expression and the transcriptional regulation of class I b-1,3-glucanase during tobacco seed germination. *Plant Molecular Biology*. 1998;38: 785-795.
- Liu X, Zhang H, Zhaob Y, Fenga Z, Lia Q, Yangc HQ, Luand S, Lie J, He ZH. Auxin controls seed dormancy through stimulation of abscisic acid signalling by inducing ARF-mediated ABI3 activation in Arabidopsis. *Proc. Natl. Acad. Sci*. 2013;110:15485-15490.
- Liu Y, Fang J, Xu F, Chu J, Yan C, Schlappi MR, Wang Y, Chu C. Expression patterns of ABA and GA metabolism genes and hormone levels during rice seed development and imbibition: A comparison of dormant and non-dormant rice cultivars. *J. Genet. Genom*. 2014;41: 327-338.
- Liu Y, Koornneef M, Soppe WJ. The absence of histone H2B monoubiquitination in the Arabidopsis hub1 (rdo4) mutant reveals a role for chromatin remodelling in seed dormancy. *Plant Cell*. 2007;19: 433-444.
- Liu Y, Li X, Zhao J, Tang X, Tian S, Chen J, Shi C, Wang W, Zhang L, Feng X. Direct evidence that suspensor cells have embryogenic potential that is suppressed by the embryo proper during normal embryogenesis. *Proc. Natl. Acad. Sci*. 2015;112: 12432-12437.
- Lotan T, Ohto M, Yee KM, West MA, Lo R, Kwong RW, Yamagishi K, Fischer RL, Goldberg RB, Harada JJ. Arabidopsis Leafy Cotyledon1 is sufficient to induce embryo development in vegetative cells. *Cell*. 1998;93: 1195-1205.
- Mabundza RM, Wahome PK, Masarirambi MT. Effects of different pregermination treatment methods on the germination of passion (*Passiflora edulis*) seeds. *Journal of Agriculture and Social Sciences*. 2010;6: 57-60.
- Macchia M, Angelini LG, Ceccarini L. Methods to overcome seed dormancy in Echinacea angustifolia. *Scientia Horticulturae*. 2001;89: 317-324.
- Maina F, Reuben M, Linnet S. Dormancy Breaking in Jute Mallow (*Corchorus olitorius*) Seeds. *Seed Technology*. 2011;33(2):147-154.
- Maiti RK, Vidyasagar P, Shahapur SC, Ghosh SK, Seiler GJ. Development and standardization of a simple technique for breaking seed dormancy in sunflower (*Helianthus annuus* L.). *Helia*. 2006;29(45): 117-126.
- Malavasi UC, Malavasi MM. Dormancy breaking and germination of *Enterolobium contortisiliquum* (Vell.) morong seed. *Brazilian Archives of Biology and Technology*. 2004;47(6): 851-854.
- Manz B, Muller K, Kucera B, Volke F, Leubner- Metzger G. Water uptake and distribution in germinating tobacco seeds investigated in vivo by nuclear magnetic resonance imaging. *Plant Physiology*. 2005;138: 1538-1551.
- Martinez P, Dicenta F. Mechanism of dormancy in seeds of peach (*Prunus persica* Batsch). *Scientia Horticulturae*. 2001;91: 51-58.
- Matilla AJ. Ethylene in seed formation and germination. *Seed Science Research*. 2000;10: 111-126.
- Matilla AJ. Auxin: Hormonal signal required for seed development and dormancy. *Plants*. 2020;9: 705.

- Matuz-Cadiz MA, Hucl P. Rapid and effective germination methods for overcoming seed dormancy in annual canary grass. *Crop Science*. 2005;45: 1696-1703.
- Mayer U, Ruiz RAT, Berleth T, Misera S, Jurgens G. Mutations affecting body organization in the *Arabidopsis* embryo. *Nature*. 1991;353: 402-407.
- Mehanna HT, Martin GC, Nishijima C. Effects of temperature, chemical treatments and endogenous hormone content on peach seed germination and subsequent seedling growth. *Scientia Horticulturae*. 1985;27: 63-73.
- Metzger. Promotion of Germination of dormant weed Seeds by Substituted Phthalimides and Gibberellic Acid. *Weed Science*. 1983;31:285-289.
- Monke G, Seifert M, Keilwagen J, Mohr M, Grosse I, Hahnel U, Junker A, Monke G, Seifert M, Keilwagen J, Mohr M, Grosse I, Hahnel U, Junker A, Weisshaar B, Conrad U, Baumlein, H. Towards the identification and regulation of the *Arabidopsis thaliana* ABI3 regulon. *Nucleic Acids Res*. 2012;40: 8240-8254.
- Morais J, Bruno B, Deminicis F, Padua T, Mirton J, Morenz F, Jorao B, Abreu R, Raphael P, Araujo D, Nepomuceno D. Methods for Breaking Dormancy of Seeds of Tropical Forage Legumes. *American Journal of Plant Sciences*. 2014;5(13):1-5.
- Moreira B, Tavsanoglu C, Pausas J. Local versus regional intraspecific variability in regeneration traits. *Oecologia*. 2011;168: 671-677.
- Morpeth DR, Hall AM. Microbial enhancement of seed germination in *Rosa corymbifera* 'Laxa'. *Seed Science Research*. 2000;10: 489-494.
- Mousavi S, Rezaei M, Mousavi A. A General Overview on Seed dormancy and methods of breaking it. *Advances in Environmental Biology*. 2011;5(10): 3333-3337.
- Muasya RM, Simiyu JN, Muui CW, Rao NK, Dulloo ME, Gohole LS. *Seed Technology*. 2009;31 (2): 134-143.
- Mukherjee A, Bordolui SK, Sadhukhan R. Stimulatory Effect of Different Plant Growth Regulators on Cosmos seed Production in New Alluvial Zone. *Biological Forum – An International Journal*. 2022; 14(2): 137-142.
- Murase K, Hirano Y, Sun TP, Hakoshima T. Gibberellin-induced DELLA recognition by the gibberellin receptor GID1. *Nature*. 2008;456: 459-463.
- Murray KG, Russell S, Picone CM, Winett-Murray K, Sherwood W, Kuhlmann ML. Fruit laxatives and seed passage rates in frugivores: consequences for plant reproductive success. *Ecology*. 1994;75: 989-994.
- Musara C, Chitamba J, Nhuvira C. Evaluation of different seed dormancy breaking techniques on okra (*Abelmoschus esculentus* L.) seed germination. *Academic journals*. 2015;10(17):1952-1957.
- Nadeau CD, Ozga JA, Kurepin LV, Jin A, Pharis RP, Reinecke DM. Tissue-specific regulation of gibberellin biosynthesis in developing pea seeds. *Plant Physiol*. 2011;156: 897-912.
- Nadella D, Gu X, Foley ME. Seed dormancy. *Encyclopedia of Applied Plant Sciences*. 2004;20 (5):1323-1333.
- Najero M, Ibrahim M, Mala V, Najero, A. Effects of different methods of breaking seed dormancy in sunflower (*H. annuus* L.). *Sci. Int*. 2012;24(4): 471-474.
- Nakabayashi K, Bartsch M, Xiang Y, Miatton E, Pellengahr S, Yano R, Seo M, Soppe WJ. The time required for dormancy release in *Arabidopsis* is determined by DELAY OF

- GERMINATION1 protein levels in freshly harvested seeds. *Plant Cell*. 2012;24: 2826–2838.
- Nakashima K, Fujita Y, Kanamori N, Katagiri T, Umezawa T, Kidokoro S, Maruyama K, Yoshida T, Ishiyama K, Kobayashi M. Three Arabidopsis SnRK2 protein kinases, SRK2D/SnRK2.2, SRK2E/SnRK2.6/OST1 and SRK2I/SnRK2.3, involved in ABA signalling are essential for the control of seed development and dormancy. *Plant Cell Physiol*. 2009;50: 1345-1363.
- Neme AN. Perennial Soybean Seeds. Results of scarification and duration of power twinning. *Bragantia: Scientific Bulletin of the Agricultural Institute of the Sao Paulo State*. 1963;22: 785-791.
- Ng LM, Melcher K, Teh BT, Xu HE. Abscisic acid perception and signalling: Structural mechanisms and applications. *Acta Pharmacol. Sin*. 2014;35: 567-584.
- Nikolaeva MG, Rasumova MV, Gladkova VN. Reference book on dormant seed germination. Nauka Publishers. 1985;9: 464–473.
- Ogawa M, Hanada A, Yamauchi Y, Kuwahara A, Kamiya Y, Yamaguchi S. Gibberellin biosynthesis and response during Arabidopsis seed germination. *Plant Cell*. 2003;15:1591–1604.
- Okunlola, A.I., Adebayo, R.A. and Orimogunje, A.D. (2011). Methods of breaking seed dormancy on germination and early seedling growth of African locust bean (*Parkia biglobosa*). *Journal of Horticulture and Forestry*. 2011;3(1): 1- 6.
- Pallavi, H.M, Gowda, R. Shadakshari, Y.G.and Vishwanath K. (2010). Study on Occurrence and Safe Removal of Dormancy in Sunflower (*Helianthus annuus* L.). *Research Journal of Agricultural Sciences*.2010;1(4): 341-344.
- Porceddu M, Mattana E, Pritchard HW, Bacchetta G. Sequential temperature control of multiphasic dormancy release and germination of *Paeonia corsica* seeds. *J Plant Ecol*. 2015;9:464-473.
- Previero CA, Martins L, Fonseca RHA, Groth D. Effect of storage of guinea grass (*Panicum maximum* Jacq.) on treatment to break dormancy. *Revista Brasileira de Sementes*. 1996;18:143-148.
- Rajasekaran LR, Stiles A, Caldwell CD. Stand establishment in processing carrots – Effects of various temperature regimes on germination and the role of salicylates in promoting germination at low temperatures. *Can J. Plant Sci*. 2001;82: 443-450.
- Rana U, Jautiyal AR. Coat imposed dormancy in *Acacia farnesiana* seeds. *Seeds Research*. 1989;17 (2): 122.
- Ray J, Bordolui SK. Effect of GA₃ on Marigold Seed Production in Gangetic Alluvial Zone. *J. of Crop and Weed*. 2020; 16(1): 120-126.
- Ray J, Bordolui SK. Effect of Seed Priming as Pre-Treatment Factors on Germination and Seedling Vigour of Tomato. *International Journal of Plant & Soil Science*. 2022; 34(20): 302-311. DOI: 10.9734/IJPSS/2022/v34i2031156
- Raz V, Bergervoet, JH, Koornneef M. Sequential steps for developmental arrest in Arabidopsis seeds. *New Phytol*. 2001;128: 243-252.
- Reddy LV, Metzger RJ, Ching TM. Effect of Temperature on Seed Dormancy of Wheat. *Crop science*. 1987;25: 455-458.

- Rehman S, Park LH. Effect of scarification, GA and chilling on the germination of golden rain-tree (*Koelreuteria paniculata*) seeds. *Scientia Horticulturae*. 2000;85: 319-324.
- Robbins WA, Porter RH. Germinability of sorghum and soybean seed exposed to low temperatures. *Am. Soc. Agron*. 2013;38: 905-913.
- Robert HS, Park C, Gutierrez CL, Wojcikowska B, Pencik A, Novak O, Chen J, Grunewald W, Dresselhaus T, Friml J. Maternal auxin supply contributes to early embryo patterning in *Arabidopsis*. *Nat. Plants*. 2018;4: 548-553.
- Roberts E H. Dormancy in rice seed II: The influence of covering structures. *Journal of Experimental Botany*. 1961;12: 430-448.
- Robertson AW, Trass A, Ladley JJ, Kelly D. Assessing the benefits of frugivory for seed germination: the importance of the de-inhibition effect. *Functional Ecology*. 2006;20: 58–66.
- Rogis C, Gibson LR, Knapp AD, Horton R. Enhancing germination of Eastern gama grass seed with stratification and gibberellic acid. *Crop Sci*. 2004;44: 549-552.
- Roscoe TT, Guillemint J, Bessoule JJ, Berger F, Devic M. Complementation of seed maturation phenotypes by ectopic expression of *ABSCISIC ACID INSENSITIVE3*, *FUSCA3* and *LEAFY COTYLEDON2* in *Arabidopsis*. *Plant Cell Physiol*. 2015;56:1215-1228.
- Rostami A, Shasavar A. Effects of Seed Scarification on Seed Germination and Early Growth of Olive Seedlings. *Journal of Biological Sciences*. 2009;9: 825-828.
- Rousselin P, Kraepiel Y, Maldiney R, Miginiac E, Caboche M. Characterization of three hormone mutants of *Nicotiana plumbaginifolia*: evidence for a common ABA deficiency. *Theoretical and Applied Genetics*. 1992;85: 213–221.
- Samuels IA, Levey DJ. Effects of gut passage on seed germination. *Functional Ecology*. 2005;19: 365–368.
- Schopfer P, Plachy C. Control of seed germination by abscisic acid: Effect on embryo water uptake in *Brassica napus* L. *Plant Physiology*. 1984;76: 155–160.
- Shanmugavalli M, Renganayaki PR, Menaka C. Seed dormancy and germination improvement treatments in fodder sorghum. *Seed Science and Technology*. 2007; 3(1):437–443.
- Shuai H, Meng Y, Luo X, Chen F, Ying Q, Yang W, Kai S. The roles of auxin in seed dormancy and germination. *Hereditas*. 2016;38(4): 314-322.
- Singh BG, Rao GR. Effect of chemical soaking of sunflower seeds on vigour index. *Indian Journal of Agricultural Sciences*. 1994; 63: 232-233.
- Singh DP, Filardo FF, Storey R, Jermakow AM, Yamaguchi S, Swain SM. Overexpression of a gibberellin inactivation gene alters seed development, *KNOX* gene expression, and plant development in *Arabidopsis*. *Physiol. Plant*. 2010;138: 74-90.
- Srivastava AK, Dey SC. Physiology of seed dormancy in sunflower. *Acta Agron. Acad. Sci. Hung*. 1982;31: 70-80.
- Steber CM, McCourt P. A role for brassinosteroids in germination in *Arabidopsis*. *Plant Physiology*. 2001;125: 763–769.
- Steber CM, Cooney SE, McCourt P. Isolation of the GA-response mutant *sly1* as a suppressor of *ABI1-1* in *Arabidopsis thaliana*. *Genetics*. 1998;149: 509-521.
- Sun TP. The molecular mechanism and evolution of the GA-GID1-DELLA signalling module in plants. *Curr. Biol*. 2011;21: 338-345.

- Suzuki T, Matsuura T, Kawakami N, Noda K. Accumulation and leakage of abscisic acid during embryo development and seed dormancy in wheat. *Plant Growth Regul.* 2000;30:253-260.
- Swain SM, Reid JB, Kamiya Y. Gibberellins are required for embryo growth and seed development in pea. *Plant J.* 1997;12: 1329-1338.
- Taba S, Van Ginkel M, Hoisington D, Poland D. Hybridization of maize and teosinte, in México and Guatemala and the improvement of maize. *Econ. Bot.* 2004;31:254-293.
- Takeuchi Y, Omigawa Y, Ogasawara M, Yoneyama K, Konnai M, Worsham AD. Effects of brassinosteroids on conditioning and germination of clover broomrape (*Orobancha minor*) seeds. *Plant Growth Regulation.* 1995;16: 153–160.
- Tang DS, Hamayun M, Khan A, Nawaz Y, Irshad M, Eunna Y. Exposure to red light, temperature and exogenous gibberellins influenced germination of some winter weed. *Afr. J. Biotech.* 2012;11: 273–279.
- To A, Valon C, Savino G, Guillemintot J, Devic M, Giraudat J, Parcy F. A network of local and redundant gene regulation governs Arabidopsis seed maturation. *Plant Cell.* 2006;18: 1642-1651.
- Tomer RPS, Maguire JD. Hard seed studies in alfalfa. *Seeds Research.* 1989;17 (1): 29-31.
- Tomlinson H, Ngandwe M, Nikiema A. Field and in vitro methods of propagation of the African locust bean tree (*Parkia biglobosa*). *J. Hortic. Sci. Biotechnol.* 2000;75: 42-49.
- Tung L, Serrano E. Effects of warm water in breaking dormancy in rice seed. *Omonrice.* 2011;18: 129-136.
- Ullah H, Chen JG, Wang SC, Jones AM. Role of a heterotrimeric G protein in regulation of Arabidopsis seed germination. *Plant Physiology.* 2002;129: 897-907.
- Wang F, Perry SE. Identification of direct targets of FUSCA3, a key regulator of Arabidopsis seed development. *Plant Physiol.* 2013;161: 1251-1264.
- Wang M, van der Meulen RM, Visser K, Van Schaik HP, Van Duijn B, De Boer AH. Effects of dormancy-breaking chemicals on ABA levels in barley grain embryos. *Seed Science Research.* 1998;8: 129-137.
- Wang Z, Cao H, Sun Y, Li X, Chen F, Carles A, Li Y, Ding M, Zhang C, Deng, X. Arabidopsis paired amphipathic helix proteins SNL1 and SNL2 redundantly regulate primary seed dormancy via abscisic acid–ethylene antagonism mediated by histone deacetylation. *Plant Cell.* 2012;25:149–166.
- Watanabe K, Sato H, Sato, H. Effect of heat on breaking seed dormancy and its varietal differences in rice to germination. *Tohoku Agricultural Research.* 1998;51: 39-40.
- Watkins JT, Cantliffe DJ. Mechanical resistance of the seed coat and endosperm during germination of *capsicum annuum* at low temperature. *Plant Physiol.* 1983;72(1): 146-150.
- Wehmeyer N, Vierling E. The expression of small heat shock proteins in seeds responds to discrete developmental signals and suggests a general protective role in desiccation tolerance. *Plant Physiol.* 2000;122: 1099-1108.
- West MA, Yee KM, Danao J, Zimmerman JL, Fischer RL, Goldberg RB, Harada JJ. LEAFY COTYLEDON1 is an essential regulator of late embryogenesis and cotyledon identity in Arabidopsis. *Plant Cell.* 1994;6: 1731-1745.

- William E, Finch S, Gerhard, L. Seed dormancy and the control of germination. *New Phytologist*. 2006;171: 501–523.
- Xiang Y, Nakabayashi K, Ding J, He F, Bentsink L, Soppe WJJ. REDUCED DORMANCY5 Encodes a Protein Phosphatase 2C that is required for seed dormancy in Arabidopsis. *Plant Cell*. 2014;26: 4362-4375.
- Yamaguchi S. Gibberellin metabolism and its regulation. *Annu. Rev. Plant Biol.* 2008;59: 225-251.
- Yamaguchi S, Smith MW, Brown RGS, Kamiya Y, Sun TP. Phytochrome regulation and differential expression of gibberellin 3 β -hydroxylase genes in germinating Arabidopsis seeds. *Plant Cell*. 1997;10: 2115–2126.
- Yamaguchi T, Wakizuka T, Hirai K, Fujii S, Fujita A. Stimulation of germination in aged rice seeds by pre-treatment with brassinolide. *Proceedings of the Plant Growth Regulation Society of America*. 1987;14: 26–27.
- Yamamoto A, Kagaya Y, Usui H, Hobo T, Takeda S, Hattori T. Diverse roles and mechanisms of gene regulation by the Arabidopsis seed maturation master regulator FUS3 revealed by microarray analysis. *Plant Cell Physiol*. 2010;51: 2031-2046.
- Yamasaki Y, Gao F, Jordan MC, Ayele, B.T. Seed maturation associated transcriptional programs and regulatory networks underlying genotypic difference in seed dormancy and size/weight in wheat (*Triticum aestivum* L.). *Plant Biol*. 2017;17: 1-18.
- Yeung EC, Meinke DW. Embryogenesis in angiosperms: Development of the suspensor. *Plant Cell*. 1993;5: 1371.
- Yoshinaga S, Furuhashi M, Heinai H, Ohsumi A. Evaluation of the period for the breaking of seed dormancy using seedling incubator in high-yielding rice variety 'Hokuriku 193. *Hokuriku Crop Science*. 2016;51: 10–12.
- Yucel E. Effects of different salt (NaCl), nitrate (KNO₃) and sulphuric acid (H₂SO₄) concentrations on the germination of some salvia species seeds. *Seed Science and Technology*. 2000;28:853-860.
- Zhang LY, Zhao P, Zhou XM, Wang W, Ma LG, Yang LB, Peng XB, Bozhkov PV, Sun MX. A bipartite molecular module controls cell death activation in the basal cell lineage of plant embryos. *PLoS Biol*. 2013;11:16.
- Zheng Z, Xu X, Crosley RA, Greenwalt SA, Sun Y, Blakeslee B, Wang L, Ni W, Sopko MS, Yao C. The protein kinase SnRK2. 6 mediates the regulation of sucrose metabolism and plant growth in Arabidopsis. *Plant Physiol*. 2009;153: 99-113.
- Zorandi H, Silveira F, Fidelis A. Fire effects on seed germination: Heat shock and smoke on permeable vs impermeable seed coats. *Flora*. 2019;253:98-106.