

# Design and Development of Ground collection system for Neem fruit

## ABSTRACT

India is one of the leading producers of neem in the world. But still, there is no mechanical system available for either harvesting the neem fruits from the tree or collecting the neem fruits from the ground. Also, the manual ground collection of neem fruit is a very laborious and time-consuming operation. The cost of ground collection of neem fruit is higher than its selling price which makes neem plantation uneconomical. The introduction of a collection system for collecting the neem fruit from the ground may represent the technological change that is the key factor for improved competitiveness. The main purpose of this work was to develop ground collection system based on the principle of suction. The design of the machinery was based on a determination of fruit geometry and its physical and engineering properties. The proposed innovation enabled a fully mechanical solution for collecting the fallen neem fruit from the ground, achieving a collection capacity of approximately  $10 \text{ kg.h}^{-1}$  with a collection efficiency of over 90%.

*Keywords: Engineering properties of Neem, Ground collection system, Neem harvester, Pneumatic operated machines, Vacuum collector.*

## 1. INTRODUCTION

Neem (*Azadirachta indica*), the “wonder tree”, belonging to the meliaceae family is one of the most suitable, valuable and versatile tree species found in the Indian sub-continent <sup>[1,4]</sup>. “India is one of the leading producers of Neem in the world by producing 4.4 lakh tonnes of Neem yielding 88,440 tonnes of oil and 3.5 lakh tonnes of cake annually and globally” <sup>[3]</sup>. “In India, it occurs throughout the larger parts of the country and majorly in the states of Uttar Pradesh, Bihar, West Bengal, Orissa, Delhi, Maharashtra, Gujarat, Andhra Pradesh and Tamil Nadu” <sup>[2]</sup>. Generally, Neem trees are often found growing scattered in the farmers’ fields and on the boundaries of fields without affecting the crops. Farmers practice this system just to meet the local demand for timber, fodder, fuelwood and also for various medicinal properties. Due to its deep tap root system, it does not compete with other annual crops.

“The flowering season of neem varies from place to place. Generally, it flowers from January to May and the ripening time of fruits is from May to August” <sup>[18]</sup>. “Neem starts bearing fruits after 5 years and comes to full bearing at the age of 10-12 years”.<sup>[7]</sup> In the initial years, fruit yield is 5-20 kg per tree per year. A mature tree produces 35-50 kg of fruit per year.<sup>[18]</sup> Oil yield varies from 40-43% of seed on dry weight basis” <sup>[5]</sup>. “It has been estimated that India’s Neem production was about 3.5 million tonnes of kernels every year. From this, about 7 lakh tonnes of oil might be recovered” <sup>[7]</sup>.

In recent years, various alternative attempts have been made to mechanize the harvest of neem fruit, but no satisfactory results had been obtained. Recently, olive fruit combing devices has been tried by a few farmers for the harvesting of neem fruit but the main disadvantage brought up was that they also pluck out the leaves with the fruit which in turn requires additional operation and human for the separation of neem leaves from the fruit.

At present, there is no mechanical system available for either harvesting the neem fruits from the tree or collecting the neem fruits from the ground. The ripened fruits fall on the ground on their own and are collected manually by the women laborers <sup>[6]</sup>. But, the manual ground collection of neem fruit is laborious and time-consuming operation <sup>[4]</sup>. A women labour can collect up to 10-15 kg per day at the labour wages of ₹250 per day. The cost of operation for the collection of neem fruit from the ground is ₹30 per kg whereas the selling

38 price of the neem fruits is only ₹25 per kg which makes it uneconomical and a loss for the  
39 growers<sup>[7]</sup>.

40 Thus, the cost of collecting the neem fruits from the ground is very high and it threatens the  
41 future of neem plantations, also whose conversion to other more modern layouts is not  
42 always possible due to several limitations. The introduction of a collection system for  
43 collecting the neem fruit from the ground may represent the technological change that is the  
44 key factor for improved competitiveness.

## 45 2. MATERIAL AND METHODS

### 46 2.1. Conceptual Framework

47 The conventional method of harvesting neem is still widely practiced by most of the farmers.  
48 The practice includes hand picking of fallen fruits, cleaning and finally bagging. All the  
49 aforementioned tasks are accomplished manually, which takes too much time and energy. In  
50 order to replace manual bagging and collection of neem from the ground, this study was  
51 carried out by looking at the existing designs of different pneumatically operated machines  
52 from developed, emerging and developing countries. Based on the findings, it was decided  
53 to adopt, adapt and simplify the good characteristics of the existing designs in order to  
54 create the prototype machine. Design criteria that satisfy the local environment were  
55 identified based on the accessibility of machine parts and components in the local market. A  
56 conceptual drawing was created based on the design specifications and design data. The  
57 functional requirements of conceptual frame work is furnished in Table 1.

58 **Table 1. Conceptual frame work of the study**

<b>Input</b>	<ul style="list-style-type: none"><li>• Relevant information gathered on existing design of pneumatically operated suction machines,</li><li>• Neem fruit characteristics and</li><li>• Availability of machine parts and components</li></ul>
<b>Process</b>	<ul style="list-style-type: none"><li>• Design conceptualization, calculations and design plan of the machine</li><li>• Fabrication of prototype.</li></ul>
<b>Output</b>	<ul style="list-style-type: none"><li>• Mobile engine-driven Neem fruit collector</li><li>• Operating characteristics of the machine</li></ul>

### 59 2.2. Properties of Neem fruit

60 The physical and aerodynamic properties of Neem fruit that influences the development of  
61 ground collection system for Neem fruits have been studied.

#### 62 2.2.1. Physical Property

63 Some physical properties required for the designing of the prototype had been determined  
64 and referred from the previous studies, which encompass the size, weight of a hundred  
65 neem fruit (Fig. 1), bulk density and moisture content of the neem fruit<sup>[4]</sup>.



66  
67

Fig. 1: Weighing of 100 neem seed using digital weighing balance.

### 68 2.2.2. Aerodynamic Property

69 The terminal velocity was determined by an air column made up of a vertical wind tunnel of  
70 diameter 44.48 mm and a height of 600 mm (Fig 2(a)). A digital anemometer (Make:Lutron  
71 Model:AM-4201) was used to determine the air speed (Fig 2(b)). A sample of the neem fruit  
72 was dropped into the air stream from the top of the air column and the air velocity was  
73 adjusted until the neem fruit came into a suspended state in the air stream <sup>[17]</sup>. The  
74 respective velocity ( $\text{m.s}^{-1}$ ) near the location of the fruit suspension was measured with the  
75 help of the digital anemometer having an accuracy of  $\pm 0.1\text{m.s}^{-1}$ . Measurement of the air  
76 velocity was replicated ten times <sup>[17]</sup>.

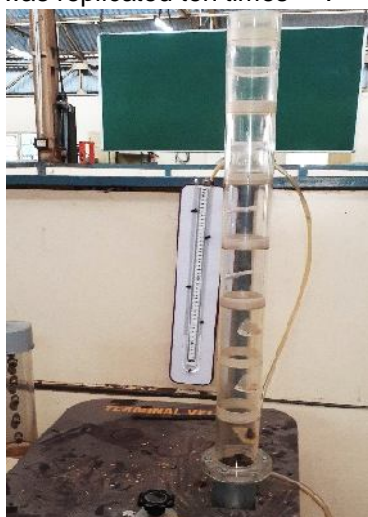

77  
78

Fig. 2(a): Vertical wind tunnel



Fig. 2(b): Digital Anemometer

### 79 2.3. Design of Major Components

80 Based on the findings of numerous studies and from the assessment of various  
81 commercially available pneumatic leaf and trash collectors, design requirements for the  
82 machine were synthesized. Some of the highlighted design requirements were: 1) the  
83 machine should efficiently collect neem fruits on levelled as well as undulated fields; 2) the  
84 machine should eliminate stones and leaves of the forage materials during suction of the  
85 neem fruit; 3) the machine should reduce drudgery and speed up collection; and 4) the  
86 machine should be of intermediate technology, made from local materials using local  
87 manufacturing technology, simple and safe to operate and maintain, functionally and

88 structurally sound, and with minimal tooling<sup>[7]</sup>. The machine majorly consists of a trolley,  
89 prime mower, suction chamber with impeller, suction hose, storage bin, etc. The details of  
90 the design requirements of the components are as follows:

### 91 2.3.1. Engine

92 The calculation of the power requirement by the machine for the suction of neem fruit was  
93 based on the pressure and velocity of airflow<sup>[9]</sup>.

94 Power consumption,

$$95 \quad (\text{KW}) = \rho_{\text{air}} \cdot Q_{\text{air}} \cdot H_{\text{air}} \times 0.746/75 \quad (1)$$

96 Where,

97  $\rho_{\text{air}}$  = density of air, 1.293 kg.m<sup>-3</sup>

98  $Q_{\text{air}}$  = air flow rate, m<sup>3</sup>.sec<sup>-1</sup>

99  $H_{\text{air}}$  = pressure head, m

$$100 \quad \text{Power consumption} = 1.293 \times 0.0729 \times 837.46 \times 0.746/75$$
$$101 \quad \quad \quad = 0.8 \text{ KW}$$

102 Since then, according to the requirements and market availability, 0.82 KW engine has been  
103 selected.

### 104 2.3.2. Impeller

105 The type of impeller selected for the study was a forward curved type as the pressure head  
106 generated by this type of impeller was found to be greater than the backward curve and  
107 radial type impellers.<sup>[11]</sup> The diameter of the impeller was 168 mm. It had been encased  
108 within the 180 mm housing all along. The selection of impeller design was based on the  
109 operation it had to perform and for the required suction purpose, forward curved impellers  
110 suit best.<sup>[10]</sup> The top view and isometric view of impeller are shown in Fig. 3(a) and 3(b).

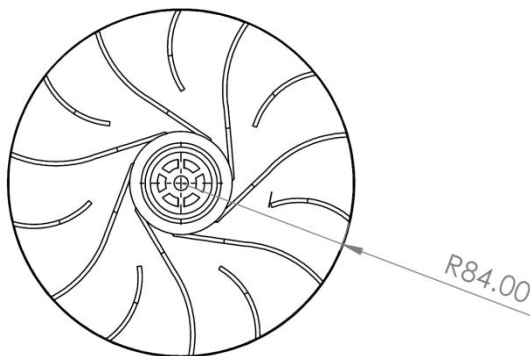

111  
112 Fig. 3(a): Top view of impeller

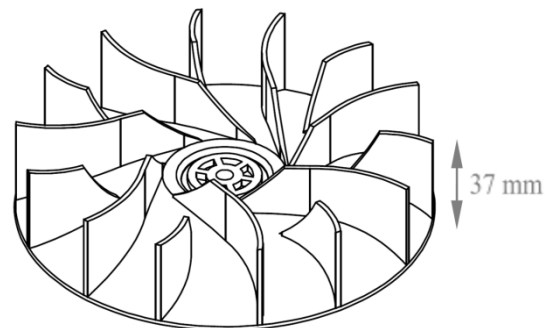

Fig. 3(b): Isometric view of impeller

### 113 2.3.3. Suction Hose

114 A flexible Poly vinyl chloride material hose pipe of 80 mm in diameter has been selected for  
115 the machine. The pipe is having spiral reinforcement of copper wire, which provides strength  
116 and also aids it to sustain its shape during the action of suction pressure inside the pipe. It  
117 is tightened at both ends with the help of a GI clamp.

### 118 2.3.4. Suction Nozzle

119 The design of the suction nozzle assembly was based on the Walinga design. The following  
120 design data were required: 1) the thickness of the fruit when spread on the ground, 2-3 cm

121 [4]; 2) the diameter of the suction pipe, 80mm; and 3) anthropometric data such as knuckle-  
122 to-elbow length, elbow height, and hand grip diameter. The overall length of the suction  
123 nozzle assembly was determined using equation (2) [11].

$$124 \quad z = \frac{y+x\cos\beta}{\sin\theta} \quad (2)$$

125 Where: z = Overall length, mm  
126 y = Elbow height, mm  
127 x = Knuckle-to-elbow length, mm  
128  $\beta$  = Angle made by arm from the vertical, 110°  
129  $\theta$  = Angle made by the handle with horizontal, 45°

$$130 \quad \mathbf{Z = 200 \text{ mm}}$$

### 131 2.3.5. Storage bin

132 A plastic storage bin is placed in the trolley below the duct. The placement of the bin is such  
133 that it catches all the neem falling out of the shutter when it gets open. The storage bin was  
134 designed based on the density and working capacity of the machine. The volume and  
135 storage capacity can be determined by using equation (3) and equation (4).

$$136 \quad \mathbf{Volume \ of \ Storage \ bin} = \text{Volume of truncated square pyramid} \\ 137 \quad = (a^2 + ab + b^2) \frac{h}{3} \quad (3)$$

138 where, a = 330 mm  
139 b = 230 mm  
140 h = 400 mm

$$141 \quad \text{Therefore, Volume} = [330^2 + (330 \times 230) + 230^2] 400/3 \\ 142 \quad = 31693333.33 \text{ mm}^2 \\ 143 \quad = \mathbf{0.0317m^3}$$

144 The density of neem seed in an average is 360 kg.m<sup>-3</sup>. [4]

145 Therefore, the storage capacity of the bin can be estimated as:

$$146 \quad \mathbf{Storage \ capacity} = \text{Volume of container} \times \text{Density of Neem} \quad (4) \\ 147 \quad = 0.0317 \text{ m}^3 \times 360 \text{ kg.m}^{-3} \\ 148 \quad = \mathbf{11.412 \text{ kg} \approx 12 \text{ kg}}$$

149  
150 Hence, based on the design requirements and market availability, the storage bin of size 330  
151 x 330 x 400 mm with the volume of 12 kg was selected.

152 The final conceptual drawing of the prototype is shown in Fig 4.

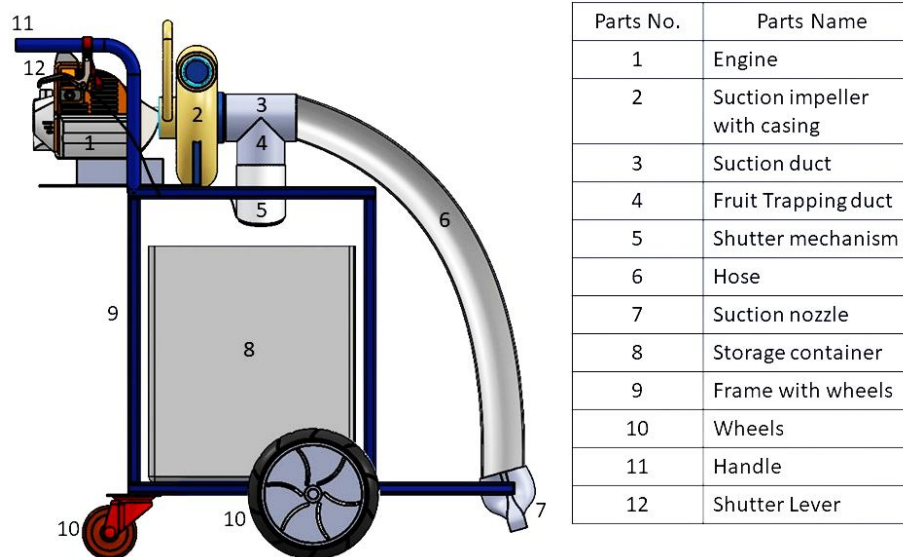

153  
154

Fig. 4. Conceptual drawing of the machine prototype.

155 **2.4. Development of Prototype**

156 The developed prototype for the ground collection of neem fruit essentially consists of the  
157 following functional system:

158 **2.4.1. Power Transmission System**

159 A 0.82 hp air cooled, single cylinder, two-stroke petrol engine was used as the prime mover  
160 for the Neem collector. The engine is directly connected to the impeller via a shaft of 10 mm  
161 in diameter which rotates the impeller at a speed of 2800 rpm. The engine was mounted on  
162 the bed provided at the top of the trolley using 4 mm diameter x 25 mm bolt.

163 **2.4.2. Suction Unit**

164 A plastic forward curved type impeller with a casing was used in the suction blower of the  
165 machine. The 168 mm diameter impeller consists of 14 blades, comprising 7 small and 7  
166 large blades cast at an angle of 30° from the centre. The blades were 37mm tall and rotated  
167 in a horizontal axis inside a 180 mm diameter casing. The suction orifice provided at the eye  
168 of the impeller was 110 mm diameter. Prior to the installation of the centrifugal impeller, a 10  
169 mm diameter hole was drilled at the centre. Then, the impeller was tightened to the engine's  
170 grooved shaft with a 5 mm diameter nut and a washer.

171 **2.4.3. Conveyance System**

172 The conveyance system of the machine included a suction nozzle assembly, suction hose,  
173 outlet shutter and diverter assembly.

174 **2.4.3.1. Suction Nozzle Assembly**

175 The suction nozzle is an important device in the vacuum conveying system. The suction  
176 head was completely flat. A 16-gauge mild steel sheet was used in the fabrication of the  
177 rectangular suction nozzle head of 200 mm x 20 mm dimension. The suction nozzle  
178 assembly's downstream portion was made of 80 mm diameter mild steel pipe. A sieve with  
179 25.4 mm of square mesh was placed inside the nozzle to allow the neem fruit to pass and

180 restrict the bigger to mesh size material to enter inside the hose. The assembly was fixed on  
181 the elongated bottom side of the frame.

#### 182 **2.4.3.2. Suction Hose**

183 An 80 mm diameter, 500 mm long copper wire reinforced flexible plastic hose was used as a  
184 conveyance line from the suction nozzle assembly to the inlet of the diversion duct.

#### 185 **2.4.3.3. Diversion Duct**

186 A 110 mm diameter, T-shape poly vinyl chloride duct with shutter mechanism at the  
187 diversion exit, was used as the diversion unit. Inside the duct, a sieve of 10 mm square  
188 mesh at the impeller opening had been placed to retain the neem fruit and divert it towards  
189 the collection box. At the bottom exit of the collection duct, a lever-operated shutter  
190 mechanism has been provided to let out the sucked neem into the storage bin whereas the  
191 foreign materials of smaller size than neem fruit will pass the sieve and blow away through  
192 the blower end.

#### 193 **2.4.3.4. Outlet Shutter**

194 A lever-operated shutter mechanism made up of mild steel had been provided at the bottom  
195 exit of the diversion duct for arresting the vacuum generated in the duct, during the suction  
196 operation. Once the suction of the neem fruit below a neem tree gets completed, the shutter  
197 can be opened by the operator by pressing the lever provided at the right-side handle  
198 against the spring pressure, for letting out the sucked neem fruit. Once after releasing the  
199 lever, the shutter shuts off again due to the spring as well as suction pressure.

#### 200 **2.4.4. Storage Section**

201 The storage section below the diversion duct supports a plastic box for bagging neem during  
202 operation. It was fixed to the channel provided in the main frame. Hence, can be removed  
203 easily as and when required. The dimensions of the plastic container was 330 x 330 x 400  
204 mm.

#### 205 **2.4.5. Supporting Frame**

206 The main frame was fabricated using 12 mm MS square pipe. A channel was also fabricated  
207 using a 12 mm MS flat bar for arresting the plastic container. On the top of the frame, a bed  
208 was provided for mounting the engine. In order to facilitate mobility, the overall structure was  
209 outfitted with one swivel caster rear wheel of 100 mm diameter, two solid rubber front wheels  
210 of 127 mm diameter, and push handles made out of metal pipe with a 12 mm diameter.

### 211 **2.5. Cost Analysis**

212 A cost analysis was done to determine the financial and economic indicators of the ground  
213 collection machine for neem fruit. The annual cost equation (5) by Hunt <sup>[13]</sup> was used in  
214 performing the simple cost analysis.

$$215 \quad AC = FC + W(Vc)/C \quad (5)$$

216 where: AC = Annual cost, Rs.yr<sup>-1</sup>  
217 FC = Fixed cost, Rs.yr<sup>-1</sup>  
218 W = Total weight of Neem seed, kg.yr<sup>-1</sup>  
219 Vc = Variable cost, Rs.h<sup>-1</sup>  
220 C = Collecting capacity, kg.h<sup>-1</sup>

221 **3. RESULTS AND DISCUSSION**

222 **3.1. Properties of Neem Seed**

223 The physical properties required for the design of the prototype have been studied and  
224 referred to in the existing studies. The trials for obtaining the terminal velocity of the neem  
225 fruit have been carried out in the laboratory setup available in the Department of Farm  
226 Machinery and Power Engineering, Agricultural Engineering College & Research Institute,  
227 Tamil Nadu Agricultural University, Coimbatore. The results obtained are tabulated in Table  
228 2.

229

**Table 2: Properties of Neem Seed**

S.No.	Properties	Value
1.	Size	
	1.1. Length	15 – 20 mm
	1.2. Geometric Mean Diameter	8 -12 mm
2.	Weight of 100 seeds	59 g
3.	Volume	4.55 - 4.57 mm <sup>3</sup>
4.	Bulk Density	354.2 – 375.1 kg.m <sup>-3</sup>
5.	Terminal Velocity	8.8 – 9.2 m.s <sup>-1</sup>

230 **3.2. Description of Ground collection machine for Neem fruit**

231 A simple mobile engine-driven pneumatically operated ground collection system for neem  
232 fruit, was designed and fabricated for collecting of Neem fruit from the field. The mobile  
233 engine-driven pneumatic Neem collector had the following major components: power  
234 transmission system, suction unit, conveyance system, storage section and frame. The  
235 ground collection machine for Neem fruit and its operation are shown in Fig. 5(a) and Fig.  
236 5(b) respectively. The specifications of the developed prototype are presented in Table 3.



Fig. 5(a). Ground collection machine for Neem fruit.



Fig. 5(b). Operational view of the ground collection machine for neem fruit.

**Table 3. Specification of the Ground collection machinery for Neem fruit**

<b>Components</b>	<b>Specifications</b>
Overall Dimensions and weight	
Length x Width x Height	950 x 440 x 955 mm
Weight	20 kg
Suction Unit	
Type	Centrifugal
Overall Dimension	255 x 150 x 360 mm
Overall Weight	5.6 kg
Impeller :	
Type	Forward Curve
Dimension (Dia. x Width)	165 x 30 mm
Number of blades	14
Suction Side	
Shape	Circular
Diameter	120 mm
Material	Plastic
Suction Nozzle Assembly	
Type	Flat
Diameter of downstream side	80 mm
Dimension of pick-up side (L X W)	200 x 25 mm
Material	Mild Steel
Suction Line	
Type	Flexible hose
Size (Diameter x Length)	400 x 500 mm
Material	Vinyl Copper wire reinforced
Wheel	
Front:	
Type	Swivel caster wheel
Size (diameter X width)	127 mm X 50 mm
Material	Plastic
Number	2
Rear:	
Type	Solid Rubber wheel
Size	100mm X 50mm
Material	Rubber
Number	1
Prime mover	
Type (Stroke/Ignition)	2 stroke
Rated power	0.82 hp
Rated speed	2800 rpm
Cooling system Air cooled	Air-cooled
Starting system	Rope ranking
Dry weight	5 kg

### 238 3.3. Simple Cost Analysis

239 A simple cost analysis was conducted to guide potential users of possible benefit projections  
240 in using ground collection machinery for neem fruit. The machine is assumed to be utilized  
241 for 400 h per annum at eight hours of operation per day. A single operator is required to  
242 operate the machine. The collection capacity of the developed machine is 10 kg.h<sup>-1</sup>.

243 The total cost of the machine was ₹ 30,000.00. The fixed cost for collecting neem fruit using  
244 the machine annually was ₹ 26.60 per hour while the variable cost was ₹ 51,169. The cost of  
245 collecting neem seed using the designed machine was ₹ 2.55.kg<sup>-1</sup> whereas the cost of neem  
246 fruit collection in conventional method was ₹30 kg<sup>-1</sup>.

247 The break-even point was 127 kg.yr<sup>-1</sup>. Utilizing the machine for 400 hours per year will  
248 generate an income of ₹10,980 yr<sup>-1</sup>. The projected time (based on 10 kg.h<sup>-1</sup> collecting  
249 capacity) needed to recover the cost of the machine was 3.64 years.

#### 250 **4. CONCLUSION**

251 This study was conducted to design, develop and evaluate the ground collection system for  
252 neem fruit. It attempted to mechanise the process of collecting neem fruit from the ground,  
253 and it addresses the issue to the greatest extent possible.

254 The ground collection machinery for neem fruit had the following major components: power  
255 transmission system, suction unit, conveyance system, storage section, and frame. The  
256 estimated collection capacity of the machine was 10 kg.hr<sup>-1</sup>. The results so far have been  
257 promising. Further improvements are advisable based on the extensive field trials.

258 The machine entailed an investment cost of ₹ 30,000; an annual generated income of Rs.  
259 10,980. yr<sup>-1</sup> at a collecting cost of ₹ 2.55 kg<sup>-1</sup>. The payback period of the machine was  
260 estimated at 3.64 years.

#### 261 **ACKNOWLEDGEMENT**

262 The author desires to extend his gratitude to the funding agency of the research, M/s.  
263 Coromandel International Ltd., Chennai for their financial support. He also puts his gratitude  
264 to the Department of Farm machinery and Power Engineering, AEC&RI, Tamil Nadu  
265 Agricultural University, Coimbatore for letting to carried out the research study.

266

#### 267 **REFERENCES**

- 268 1. Roshan A, Verma NK. A brief study on neem (Azardirachta indica A.) and its  
269 application—A review. Research Journal of Phytomedicine. 2015;1(1):01-3.
- 270 2. Uchegbu M, Okoli I, Esonu B, Iloeje M. The growing importance of neem (Azadirachta  
271 indica A. Juss) in agriculture, industry, medicine and Environment: A review. Research  
272 Journal of Medicinal Plant. 2011;5(3):230-45.
- 273 3. "Need to sustain neem production: Experts." *The Times of India* [Bengaluru], 4  
274 December 2018.[www.timesofindia.indiatimes.com/city/bengaluru/need-to-sustain-neem-  
275 production-experts/articleshow/66930603.cms](http://www.timesofindia.indiatimes.com/city/bengaluru/need-to-sustain-neem-production-experts/articleshow/66930603.cms)
- 276 4. Adedeji MA, Owolarafe OK. Some Physical Properties of Neem Seeds & Kernels  
277 (Azandirachta indica) as a Function of moisture Content. Carbon. 2015;86(74.45):78-92.
- 278 5. Nnnam RE, Okoro OI, Oko AN, Oji CO. Crop Protectant From Pest By Neem  
279 (Azadirachta Indica) Oil Bioinsecticide. CENTRAL ASIAN JOURNAL OF THEORETICAL  
280 & APPLIED SCIENCES. 2021;2(2):63-76.
- 281 6. Swaminathan C, Raguraman S. Silviculture of neem and its role in agroforestry and  
282 social forestry. New Delhi: IK International Publishing House Pvt. Ltd.; 2008.

- 283 7. Phogat, V., Kumar, Sanjay., Singh, KK., and Satyavan "Techniques of neem plantation  
284 and its economic benefits" *Neem, a treatise*, edited by Singh, K. K., IK International Pvt  
285 Ltd, 2009, 53-66.
- 286 8. Angeles AV. Design, construction and performance test of a clay extruder machine for  
287 small-scale brick-making [Philippines].
- 288 9. Sharma,D.N. and Mukesh, S., "Field Performance of Farm Machinery" *Farm Power and*  
289 *Machinery Management*,Jain Brothers (New Delhi), 2013, 87-170.
- 290 10. Shah KH, Vibhakar NN, Channiwala SA. Unified design and comparative performance  
291 evaluation of forward and backward curved radial tipped centrifugal fan. InProceedings  
292 of the International Conference on Mechanical Engineering 2003.
- 293 11. LATT AK, SAN YIN HT, TIN TS, ZAW M. Design Comparison of Forward and Backward  
294 Curved Radial Tip Blades for Centrifugal Blower. 2019.
- 295 12. Zubia OF, Sumministrado DC, Resurreccion AN, Amongo RM, Paras Jr FO, Petingco MC.  
296 Anthropometry of male farmers in Laguna, Philippines and its potential applications in  
297 the design of agricultural machines and tools. Philippine Journal of Agricultural and  
298 Biosystems Engineering (Philippines). 2010.
- 299 13. Mohamed MA, Kheiry AN, Rahama AE, Alameen AA. Optimization Model for Machinery  
300 Selection of Multi-Crop Farms in Elsuki Agricultural Scheme. Turkish Journal of  
301 Agriculture-Food Science and Technology. 2017;5(7):739-44.
- 302 14. Cost of operation of Machinery. Retrived July 19,2022, from  
303 <http://ecourseonline.iasri.res.in/mod/page/view.php?id=2268>
- 304 15. Jokela D, Nair A. No tillage and strip tillage effects on plant performance, weed  
305 suppression, and profitability in transitional organic broccoli production. *HortScience*.  
306 2016;51(9):1103-10.
- 307 16. Lips M. Repair and maintenance costs for nine agricultural machine types.  
308 *Transactions of the ASABE*. 2013;56(4):1299-307.
- 309 17. Fos' hat M, Etemad V, Gharibzahedi SM, Ghahderijani M. Physical, Mechanical  
310 and Aerodynamic Properties of Acorn ('*Quercus suber*'L.) as Potentials for  
311 Development of Processing Machines. Australian Journal of Crop Science.  
312 2011;5(4):473-8.
- 313 18. Balami AA, Aliyu M, Dauda SM, Peter O. Physical properties of neem (*azadirachta*  
314 *indica*) seeds and kernels relevant in the design of processing machineries. 2014