

# Original Research Article

## Trend and Time series analysis of vegetation dynamics using satellite data: A case study of Uttarakhand, India

### ABSTRACT

**Aims:** To collect time series data for Normalized Difference Vegetation Index (NDVI) band using google earth engine (GEE) and MOD13A1 V6.1 product for the region of Uttarakhand, Uttarakhand districts and Himachal Pradesh. Thereafter investigation and comprehension of the viability of using MODIS NDVI satellite data time series to identify trends and give a forecast model.

**Study design:** Time series data was collected using Google Earth Engine for NDVI indices for the period of the year 2010 to 2022. Trend analysis and time series analysis were performed for collected data.

**Methodology:** NDVI time series data set is collected using GEE for Uttarakhand state, its districts and Himachal Pradesh State. The method which is used to find trend analysis of above regions is Mann-Kendall (MK). NDVI dataset in which the time series data is divided into train and test dataset. 5 types of forecasting models are used to forecast NDVI time series dataset i.e., Long short-term memory (LSTM), Bidirectional Long short-term memory (BiLSTM), Support vector regression (SVR), Autoregressive Integrated Moving (ARIMA), Adaptive Neuro fuzzy interference system (ANFIS) models are trained using train data and are used to generate the predicted value. The predicted value is then compared with test data using various metrics for forecasting NDVI time series.

**Results:** Trend analysis of NDVI shows an increasing trend in NDVI values for Uttarakhand and its districts as well as Himachal Pradesh. ANFIS model resulted  $R^2$  value of 0.6702, RMSE value of 0.038015848, MAE value of 0.027941089, MSE value of 0.001445205 and MAPE value of 0.061556184. Stacked LSTM model resulted  $R^2$  value of 0.7541, RMSE value 0.036419336, MAE value of 0.026412653, MSE value of 0.001326368 and MAPE value of 0.056518498. Bidirectional LSTM model resulted with highest  $R^2$  value of 0.8365, RMSE value 0.027757431, MAE value of 0.021041361, MSE value of 0.000770475 and MAPE value of 0.044492608. Autoregressive Integrated Moving Average (ARIMA) model resulted with lowest  $R^2$  value of 0.153, RMSE value 0.061512055, MAE value of 0.04393482, MSE value of 0.003783733 and MAPE value of 0.095554665. SVR model resulted with  $R^2$  value of 0.6719, RMSE value 0.037469169, MAE value of 0.0275219099, MSE value of 0.0014039386 and MAPE value of 0.61063698.

**Conclusion:** Trend analysis shows an increasing trend for the Uttarakhand state. Rudrapur, Chamoli, Uttarkashi and Pithoragarh show an increasing trend in NDVI values but the magnitude is less than in other districts. Dehradun and Almora districts show an increasing trend in NDVI values with a significant magnitude of increase in NDVI values. Bidirectional LSTM model gives the best results when used as a forecasting model.

**Keywords:** NDVI, LSTM, ARIMA, ANFIS, *vegetation dynamics, India*

Formatted: English (United States)

Formatted: Font: (Default) +Body, Not Bold

Formatted: Font: (Default) +Body

Formatted: Body, Left

Formatted: Font: (Default) +Body, Not Superscript/ Subscript

Formatted: Font: (Default) +Body

Formatted: Font: (Default) +Body, Not Superscript/ Subscript

Formatted: Font: (Default) +Body

Formatted: Font: (Default) +Body, Not Superscript/ Subscript

Formatted: Font: (Default) +Body

Formatted: Font: (Default) +Body, Not Superscript/ Subscript

Formatted: Font: (Default) +Body

Formatted: Font: (Default) +Body, Not Superscript/ Subscript

Formatted: Font: (Default) +Body

Formatted: Font: (Default) +Body, English (United States)

Formatted: Font: (Default) +Body

**Comment [A1]:** The summary is too long, it is better to reduce it and you do not exceed 250 words in total, for example you do not show the details of the methodology and the results..

Formatted: Font: (Default) +Body

Formatted: Font: Not Bold

Formatted: Font:

## 1. INTRODUCTION

Vegetation is an essential part of terrestrial ecosystems and regulates the world's energy and material cycles in ways that cannot be replaced. It's a significant indicator of terrestrial metabolic processes and, exhibits remarkable spatiotemporal variation. For a better knowledge of biochemical processes and their possible feedback on the climate system, systematic monitoring of analysis of vegetation dynamics is necessary. This will improve our ability to anticipate, mitigate, and adapt to future climate change and hence vegetation sustainability.[1][2]. The Google Cloud Platform powers the Google Earth Engine (GEE), a cloud-based computation and analysis tool for geospatial data. It has various freely available remote sensing datasets and is leveraged to gather Normalized Difference Vegetation Index (NDVI) and Enhanced Vegetation Index (EVI) time series data related to vegetation for a region of interest without directly accessing satellite imagery[3][4]. NDVI and gives a numerical value for the vegetation for an area of interest by measuring the difference between near-infrared and red. The NDVI value ranged from -1 to 1, where positive values indicate greater greenery (vigour) and negative values indicate surfaces that are not covered by vegetation, such as urban areas, bare soil or land, water, or ice. EVI also quantifies vegetation greenery and takes into consideration for corrections to be made in atmospheric conditions, canopy background noise and is more sensitive in areas with dense vegetation while calculating indices [4][5][6]. Researchers have applied MK trend analysis to NDVI and EVI time series datasets to find out trends in the growth of vegetation [7][8][9]. The statistical autoregressive integrated moving average (ARIMA), Markov chain model, multiple layer perceptron (MLP), artificial neural network (ANN), and prediction methods have all been developed and utilized to predict NDVI time series. But these methods have limitations like the parametric model ARIMA requires stationary data, Markov chain model only considers the present state of knowledge to predict the future. The findings of ANN, a neural network model, are less effective than those of recently recurrent neural networks since it lacks memory to store the information of previous data.

*A comprehensive study is done and it is found that till now no research have been published for NDVI time series prediction for Uttarakhand region using deep learning models LSTM BiLSTM.*

The goals of this paper are: (1) to collect NDVI and EVI time-series data for Uttarakhand and its districts region (2) to apply MK statistical method to find trends of NDVI time series dataset (3) to develop and evaluate an LSTM model for NDVI time series dataset. (4) Compare the result obtained from LSTM models applied to NDVI data with other traditional forecasting models

## 2. STUDY CONTEXT AND METHODOLOGY

### 2.1 Study Context area:

The territory of Uttarakhand State is located in south of Asia Continent and North of India with an area of 53,485 sq. km. The territory extends from 28°43' - 31°27' N latitudes and 77°34' - 81°02' E longitudes. The orography of Uttarakhand is quite diverse with mountain systems, plains and valleys, snow cover. Its area is covered by 86% mountainous and 65% forest. The State has 13 districts out of which ten regions (Uttarkashi, Tehri, Pithoragarh, Almora, Nainital, Rudraprayag, Chamoli, Pauri, Gopeshwar, Champawat) are hilly districts and three Regions comes under (U. S. Nagar, Dehradun, Haridwar) plain as well as and hilly districts. The majority of hilly regions are rural areas and plain regions are urban areas. The population of Uttarakhand is 1.14 Crores (year 2021). Figure 1 shows study area and population density map of Uttarakhand retrieved using GEE and GPWv411: Population Density dataset. [10]

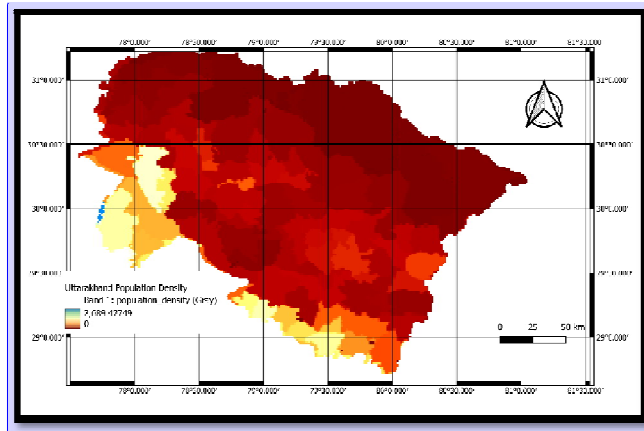

Figure 1 Uttarakhand Population Density Map

**Comment [A2]:** It is best to put a map of the location of the study area in relation to the map of India to make it easier for readers to know the situation in this area.

## 2.2 Dataset

The NDVI TS is collected using GEE for the region of Uttarakhand and its districts from the 16-day MODIS NDVI product at 250 m spatial resolution (MOD13Q1 collection 6) for the period (2000-2022 (July)). Figure 2 summarizes NDVI and EVI time series data collection for further analysis.

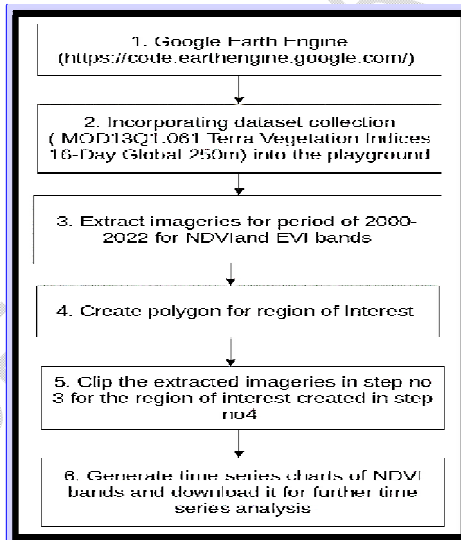

Figure 2 Steps undertaken to collect time series NDVI and EVI dataset for Uttarakhand and its districts

**Comment [A3]:** Rewrite this schematic to make it clearer than this image

## 2.3 Methodology

Time series data collected by following steps given in section 2.2 were input to MK test and different types of LSTM models. Figure 3 shows the steps that were followed to do trend analysis and forecasting.

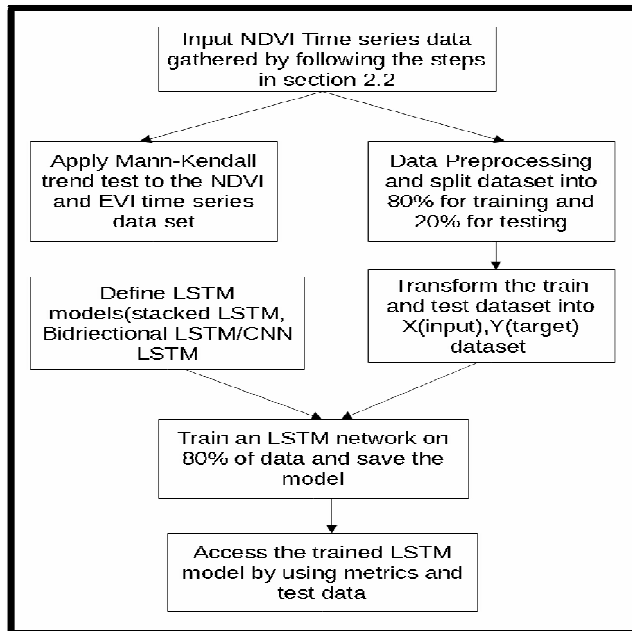

Figure 3 Flow chart for Trend analysis and Forecasting of NDVI time series dataset

### 2.3.1 MK test

The non-parametric [Mann Kendall \(MK\)](#)[11] test is commonly used in the various datasets of meteorology and hydrology to find trends in time series data. MK is applied to the NDVI time series data gathered using steps given in section 2.2 to identify trends. MK test is a non-parametric test and does not require ordered data to be any in kind of distribution. The following steps were followed to apply the MK statistic:

- a. Each element in time series data is compared to the following data item of the series and if there is a higher value in subsequent data, the S is increased by 1 and otherwise S is decreased by 1.
- b. Calculate the value of S i.e MK statistic: Equations 2 and 3 below are used to calculate the value of S i.e MK statistic.
- c. Variation of S is calculated using Equation 4.
- d. Normalized statics Z is calculated using Equation 1.
- e. Calculate the probability using Equation 5 associated with the Z calculated in step d.
- f. The trend in time series is deduced as follows: -
  - i) decreasing if Z is negative and computed probability is greater than the level of significance (95% typically)
  - ii) increasing if Z is positive and computed probability is greater than the level of significance (95% typically)
  - iii) no trend If the computed probability is less than the level of significance (95% typically)
  - iv) A simple Sen's Method to calculate magnitude of trend is calculated using Equation 6.

Comment [A4]: MK is Mann Kendall right? the best to write the full name

$$Z = \begin{cases} \frac{S-1}{\sqrt{\text{Var}(S)}} & \text{if } S > 0 \\ 0 & \text{if } S = 0 \\ \frac{S+1}{\sqrt{\text{Var}(S)}} & \text{if } S < 0 \end{cases} \quad (1)$$

$$S = \sum_{k=1}^{n-1} \sum_{j=k+1}^n \text{sgn}(x_j - x_k) \quad (2)$$

$$\text{sgn}(x_j - x_k) = \begin{cases} +1 & \text{if } (x_j - x_k) > 0 \\ 0 & \text{if } (x_j - x_k) = 0 \\ -1 & \text{if } (x_j - x_k) < 0 \end{cases} \quad (3)$$

$$\text{Var}(S) = \left[ n(n-1)(2n+5) - \sum_{i=1}^m t_i(t_i-1)(2t_i+5) \right] / 18 \quad (4)$$

$$f(Z) = \frac{1}{\sqrt{2\pi}} e^{-\frac{z^2}{2}} \quad (5)$$

$$\beta = \text{median} \left( \frac{x_j - x_k}{j - i} \right), j > i \quad (6)$$

### 2.3.2 LSTM and Different LSTM Networks

[12] Introduced the LSTM and compared to Recurrent Neural Networks, it has showed better performance in forecasting time series data. LSTM handles long-term dependencies and fixes the vanishing gradient issue by remembering all of the prior information that the network has seen while forgetting any information that is not relevant. This is achieved by applying different activation function layers called gates. LSTM cell has three gates. The forget gate determines using equation 1 what information must be regarded and what can be disregarded. The value of the fresh information carried by the input is measured by the input gate using equation 2. Output gate uses equation 6 which chooses what output (next Hidden State) the present Internal Cell State will produce. Fig 4 show LSTM cell arrangement and fig 5 show architecture of a LSTM cell.

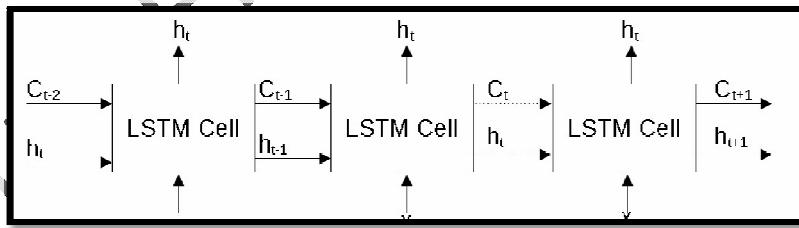

Figure 4 LSTM cell arrangement

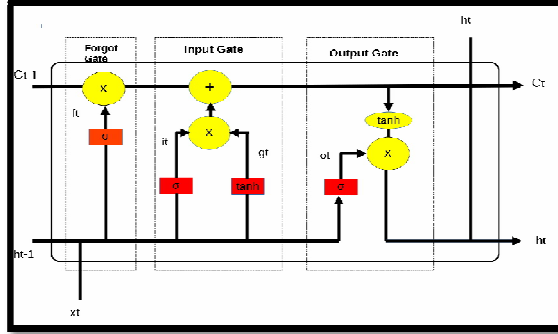

Figure 5 Architecture of LSTM cell with forget ,input and output gate

$$f_t = \sigma(W_{fh}h_{t-1} + W_{fx}x_t + b_f) \quad (7)$$

$$i_t = \sigma(W_{ih}h_{t-1} + W_{ix}x_t + b_i) \quad (8)$$

$$g_t = \tanh(W_{gh}h_{t-1} + W_{gx}x_t + b_g) \quad (9)$$

$$f_t = \sigma(W_{fh}h_{t-1} + W_{fx}x_t + b_f) \quad (10)$$

$$c_t = f_t \cdot c_{t-1} + i_t \cdot g_t \quad (11)$$

$$o_t = \sigma(W_{oh}h_{t-1} + W_{ox}x_t + b_o) \quad (12)$$

$$h_t = o_t \cdot \tanh(c_t) \quad (13)$$

A variant of LSTM models: Stacked and Bidirectional LSTM types of LSTM is used for forecasting NDVI time series dataset.

### 2.3.3 Adaptive Neuro FIS (ANFIS)

The Takagi–Sugeno FIS provides the foundation for an ANFIS or adaptable network-based FIS. In the early 1990s, this method was created. It can combine the advantages of NNs and FL into a single framework because of the way it incorporates both. Its inference system is based on a set of fuzzy IF-THEN rules with the capacity to learn and estimated nonlinear functions. As a result, ANFIS is called a universal estimator[13]. ANFIS network is made up of a collection of nodes that are arranged in layers to carry out different tasks. Figure 6 shows ANFIS architecture and consists of six layers, operations of layers are briefly explained as follows:

- **Input layer:** Input signals, which are taken from each of the nodes on this layer, are transferred into other layers.
- **Input Membership Function layer:** This is called the fuzzification layer. ANFIS model uses the current Bell activation function as the membership function in order to divide input values into fuzzy sets.
- **Rule layer:** Each node in this layer expresses the rules and number of the Sugeno fuzzy logic deduction system.
- **Normalization Layer:** Each node in this layer assumes all the nodes coming from rule layer as the input value, and it calculates the normalized ignition level of each rule.
- **Output Membership Function layer:** This is the debugging layer. In this layer, weighted result values of a rule, which is given in each node, are calculated.
- **Output Layer:** This is the sum layer. There is only one node in this layer, and it is tagged with  $\Sigma$ . Here, output values of each node in the fifth layer are added to each other, and a real value of ANFIS system is obtained.

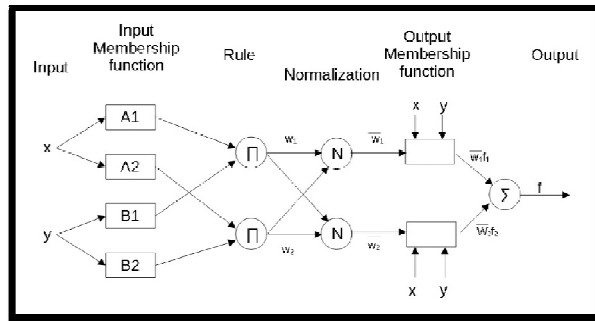

Figure 6 ANFIS Architecture

### 2.3.3 Prediction accuracy Measures

Several statistical metrics were used to evaluate the model's ability to predict outcomes. Following are the metrics used to measure the accuracy of the model

#### i) Root Mean Square Metric (RMSE)

The root mean square metric is used to measure the accuracy of prediction and can be calculated by using equation 14

$$\text{RMSE} = \sqrt{\frac{\sum_{i=1}^n (\hat{y}(i) - y(i))^2}{n}} \quad (14)$$

Formatted Table

Where  $\hat{y}(i)$  is the predicted value and  $y(i)$  is the actual value.

ii) The correlation between the actual and predicted production is indicated by the determination coefficient ( $R^2$ ) and calculated using equation 15, which ranges from zero to one (both inclusive). One number denotes a perfect model, whereas zero denotes a random one.

$$R^2 = \frac{\sum_{i=1}^n (y - \bar{y})(\hat{y} - \bar{\hat{y}})^2}{\sqrt{\sum_{i=1}^n (y - \bar{y})^2 \sum_{i=1}^n (\hat{y} - \bar{\hat{y}})^2}} \quad (15)$$

y is actual output,  $\hat{y}$  is the predicted value,  $\bar{y}$  is the average of actual value  $\bar{\hat{y}}$  is the average of the predicted value

iii) Mean absolute error (MAE) the absolute error existing between the real and predicted output and calculated using equation 16.

$$\text{MAE} = \frac{1}{n} \sum_{i=1}^n |y - \hat{y}| \quad (16)$$

Where y is the actual value and  $\hat{y}$  is the predicted value

iv) Mean square error (MSE) the average squared error existing between the predicted and real output and calculated using equation 17.

$$\text{MSE} = \frac{1}{n} \sum_{i=1}^n (y - \hat{y})^2 \quad (17)$$

Where y is the actual value and  $\hat{y}$  is the predicted value

Formatted: Font: 11 pt, Spanish (Spain, International Sort)

Formatted: Font: 11 pt, Spanish (Spain, International Sort)

Formatted: Font: 11 pt, Spanish (Spain, International Sort)

Formatted: Font: Spanish (Spain, International Sort)

## 3. RESULTS AND DISCUSSION

The current research is an experimental study to monitor the vegetation trends and dynamics of Uttarakhand state and its districts. Fig 7 shows the time series data extracted for Uttarakhand region. The MK test and Sen's slope were used to assess the trends for NDVI and forecasting models were applied to the time series NDVI dataset of Uttarakhand.

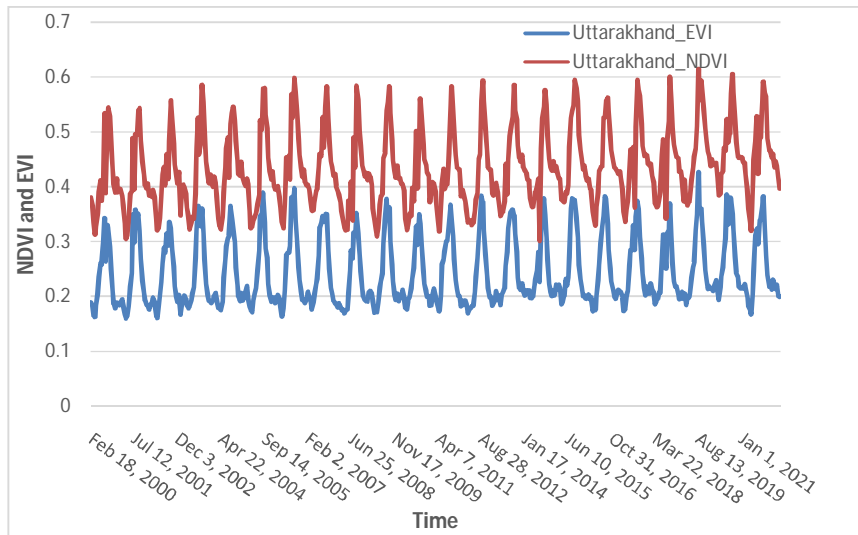

Figure 7 NDVI and EVI time series dataset for Uttarakhand region

Trend analysis is carried out on the NDVI variables, and the results of MK test along with the Z value and Sen's slope giving the magnitude of trend are given in Table 1. The table clearly shows strong growing trends in NDVI for Uttarakhand, its districts and Himachal Pradesh. All districts of Uttarakhand show an increasing trend of NDVI with a varied magnitude of slope. Rudraprayag, Chamoli, Uttarkashi and Pithoragarh show an increasing trend in NDVI values but the magnitude of increasing slope is less than in other districts. Dehradun and Almora show an increasing trend in NDVI values with a significant magnitude of increase in NDVI values.

Table 1 Mann Kendall Test performed on NDVI data obtained from period of 01.01.2000 to 01.03.2022 for Uttarakhand districts, Uttarakhand and Himachal Pradesh

Comment [A5]: Put the title above the table

SN	Uttarakhand Districts	Mann_Kendall_Test		
		Trend	Slope	Z-Value
1	PauriGarwal	increasing	0.0001492	4.6814628
2	Dehradun	increasing	0.0001499	6.2331284
3	Bageshwar	increasing	0.0001017	4.684376
4	Rudraprayag	increasing	8.2191e-5	3.526647
5	Tehri	increasing	0.0001198	5.135669
6	Pithoragarh	increasing	6.775e-05	3.494320
7	Champawat	increasing	0.000125	4.138878
8	UdhamsingNagar	increasing	0.00014285	4.411997
9	Nainital	increasing	0.00012806	4.653579
10	Chamoli	increasing	5.92e-05	3.382434
11	Haridwar	increasing	0.0001475	4.918854
12	Almora	increasing	0.0001459	5.302862
13	Uttarkashi	increasing	6.593e-05	2.949629
	<b>States</b>			

1	Uttarakhand	increasing	0.000107003	5.344923
2	Himachal Pradesh	increasing	8.750e-05	5.666895

Table 1 Mann Kendall Test performed on NDVI data obtained from period of 01.01.2000 to 01.03.2022 for Uttarakhand districts, Uttarakhand and Himachal Pradesh

Comment [A6]: Put the title above the table

As stated earlier forecasting models were applied to NDVI times series data set, Figures 8-15 along with table 2 shows the results of time series forecasting models applied for forecasting in test data of NDVI. These models were first trained with 80 percent of NDVI data (Training Data) and then trained model is used to generate predicted values of NDVI. Thereafter, the predicted values were compared to 20 percent of NDVI data (Test data) using various metrics discussed in previous section. Results obtained after various hyper parameters values pertaining to models were applied and the metrics values that resulted in R<sup>2</sup> value close to 1 is selected were chosen as best model for forecasting. ANFIS model resulted R<sup>2</sup> value of 0.670, RMSE value of 0.038015848, MAE value of 0.027941089, MSE value of 0.001445205 and MAPE value of 0.061556184. Stacked LSTM model resulted R<sup>2</sup> value of 0.7541, RMSE value 0.036419336, MAE value of 0.026412653, MSE value of 0.001326368 and MAPE value of 0.056518498. Bidirectional LSTM model resulted with highest R<sup>2</sup> value of 0.8365, RMSE value 0.027757431, MAE value of 0.021041361, MSE value of 0.000770475 and MAPE value of 0.044492608. ARIMA model resulted with lowest R<sup>2</sup> value of 0.153, RMSE value 0.061512055, MAE value of 0.04393482, MSE value of 0.003783733 and MAPE value of 0.095554665. SVR model resulted with R<sup>2</sup> value of 0.6719, RMSE value 0.037469169, MAE value of 0.0275219099, MSE value of 0.0014039386 and MAPE value of 0.61063698.

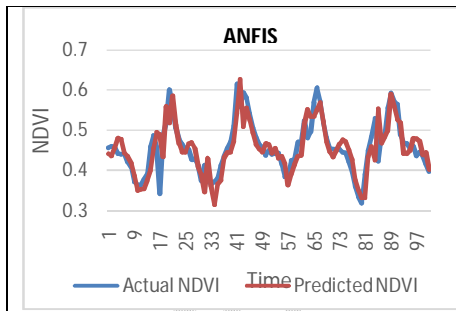

Figure 8 ANFIS results: Actual Vs Predicted NDVI

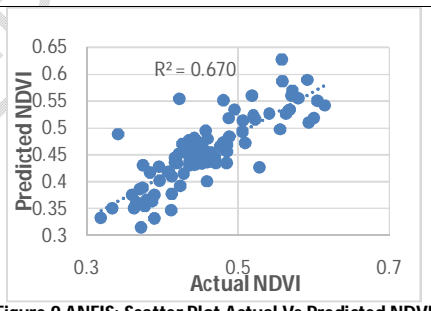

Figure 9 ANFIS: Scatter Plot Actual Vs Predicted NDVI

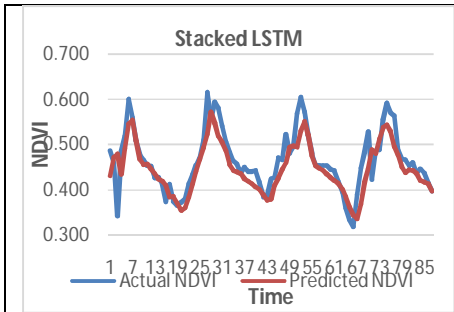

Figure 10 Stacked LSTM results: Actual Vs Predicted NDVI

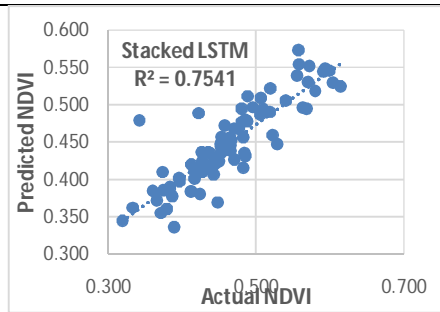

Figure 11 Stacked LSTM: Scatter Plot Actual Vs Predicted NDVI

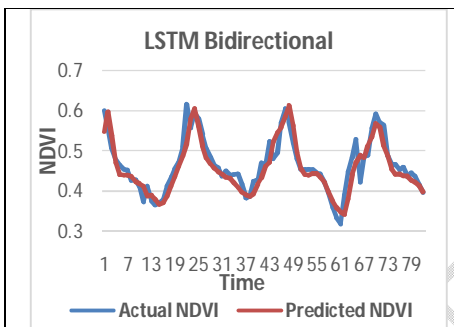

Figure 12 LSTM Bidirectional results: Actual Vs Predicted NDVI

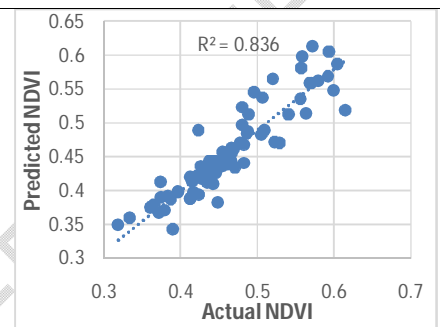

Figure 13 Bidirectional LSTM: Scatter Plot Actual Vs Predicted NDVI

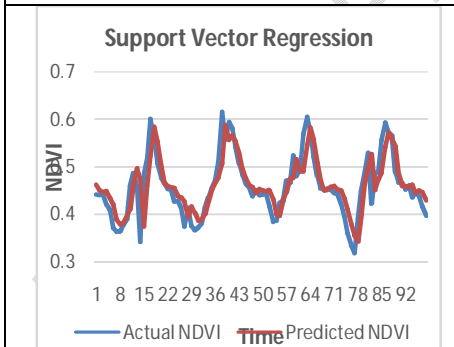

Figure 14 SVR results: Actual Vs Predicted NDVI

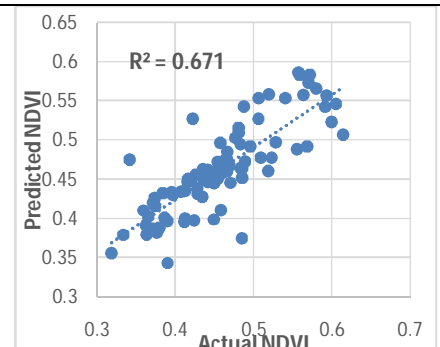

Figure 15 SVR Scatter Plot Actual Vs Predicted NDVI

[Table 2 Statistical results \(testing period\) of the five-time series forecasting models](#)

SN	Method	Root Mean	R <sup>2</sup>	Mean	Mean	Mean
----	--------	-----------	----------------	------	------	------

		Squared Error		Absolute Error	Squared Error	Absolute Percentage Error
1	ANFIS	0.038015848	0.6702	0.027941089	0.001445205	0.061556184
2	Stacked LSTM	0.036419336	0.7541	0.026412653	0.001326368	0.056518498
3	Bidirectional LSTM	0.027757431	0.8365	0.021041361	0.000770475	0.044492608
4	ARIMA	0.061512055	0.153	0.04393482	0.003783733	0.095554665
5.	SVR	0.037469169	0.6719	0.0275219099	0.0014039386	0.061063698

**Table 2 Statistical results (testing period) of the five time series forecasting models**

Figure 16 shows a color-coded map of Uttarakhand mean NDVI for the period of years 2000-2004, similarly Figure 17 shows a color-coded map of Uttarakhand mean NDVI for the period of years 2020-2022 and figure 18 shows a color-coded map of Uttarakhand which depicts the differences of NDVI mean of year 2000 and 2022. Figure 19 shows histogram of NDVI difference of NDVI mean per pixel value of the years for the year 2000 and 2022 and the frequency of most changed pixel (difference NDVI value is -0.0588) found has a frequency of greater than 1200 pixels.

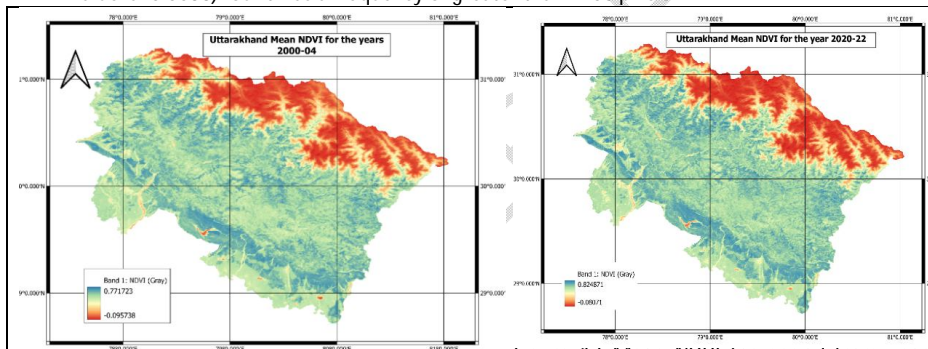

Figure 16 Mean NDVI for period from year 2000-2004

Figure 17 Mean NDVI for period from year 2020-2022

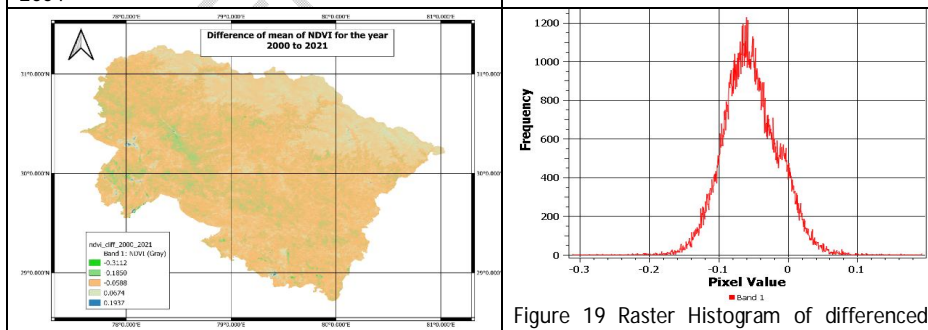

Figure 18 difference of NDVI mean from year\_2000\_2021

Figure 19 Raster Histogram of differenced NDVI mean pixel values of average image of year 2000 and 2021

**Comment [A7]:** Enlarge the size (10 in height and 14 in width of figures 16, 17, 18 and 19 to be well displayed from the results...

#### 4. CONCLUSION

In this research, NDVI time series data for the period of the years 2000-2022 were collected for Uttarakhand, its Districts and Himachal Pradesh using GEE. Trend analysis is done for the collected

time series data and found that Uttarakhand and its districts shows an increasing trend in NDVI values from year 2000 to 2022 with a varied magnitude. District Uttarkashi shows an increasing trend in NDVI values but with minimum magnitude. Uttarakhand state NDVI shows better magnitude in of increasing trend as compared to Himachal Pradesh. LSTM Time series forecasting methods shows better results than traditional forecasting methods. In future, more time series dataset can be added to analyse the impact on NDVI for a particular region.

## References

1. BAI, Y. Analysis of vegetation dynamics in the Qinling-Daba Mountains region from MODIS time series data. **Ecological Indicators**, v. 129, p. 108029, 2021. Formatted: Justified
2. VASILAKOS, C.; TSEKOURAS, G. E.; KAVROUDAKIS, D. LSTM-Based Prediction of Mediterranean Vegetation Dynamics Using NDVI Time-Series Data. **Land**, v. 11, p. 923, 2022. Formatted: Justified
3. AMANI, M. et al. Google Earth Engine Cloud Computing Platform for Remote Sensing Big Data Applications: A Comprehensive Review. **IEEE Journal of Selected Topics in Applied Earth Observations and Remote Sensing**, v. 13, p. 5326-5350, 2020. Formatted: Justified
4. DOBBS, C.; NITSCHKE, C.; KENDAL, D. Assessing the drivers shaping global patterns of urban vegetation landscape structure. **Science of the Total Environment**, v. 592, p. 171-177, 2017. Formatted: Justified
5. XUE, J.; SU, B. Significant remote sensing vegetation indices: A review of developments and applications. **Journal of sensors**, v. 2017, 2017. Formatted: Justified
6. ECKERT, S. et al. Trend analysis of MODIS NDVI time series for detecting land degradation and regeneration in Mongolia. **Journal of Arid Environments**, v. 113, p. 16-28, 2015. Formatted: Justified
7. GUO, M. et al. Detecting global vegetation changes using mann-kendal (MK) trend test for 1982–2015 time period. **Chinese Geographical Science**, v. 28, p. 907-919, 2018. Formatted: Justified
8. LI, Z. et al. Monitoring and modeling spatial and temporal patterns of grassland dynamics using time-series MODIS NDVI with climate and stocking data. **Remote Sensing of Environment**, v. 138, p. 232-244, 2013. Formatted: Justified
9. GANDHI, G. M. et al. Ndvi: Vegetation change detection using remote sensing and gis—A case study of Vellore District. **Procedia computer science**, v. 57, p. 1199-1210, 2015. Formatted: French (France)
10. WARSZAWSKI, L. et al. Center for International Earth Science Information Network—CIESIN—Columbia University.(2016). Gridded population of the World, Version 4 (GPWv4): Population density. Palisades. NY: NASA Socioeconomic Data and Applications Center (SEDAC). doi: 10. 7927/H4NP22DQ. **Atlas of Environmental Risks Facing China Under Climate Change**, p. 228, 2017. Formatted: Justified
11. HUSSAIN, M.; MAHMUD, I. pyMannKendall: a python package for non parametric Mann-Kendall family of trend tests. **Journal of Open Source Software**, v. 4, p. 1556, 2019. Formatted: Justified
12. HOCHREITER, S.; SCHMIDHUBER, J. Long short-term memory. **Neural computation**, v. 9, p. 1735-1780, 1997. Formatted: Justified
13. JANG, J.-S. R. ANFIS: adaptive-network-based fuzzy inference system. **IEEE transactions on systems, man, and cybernetics**, v. 23, p. 665-685, 1993. Formatted: Justified
14. LIM, B.; ZOHREN, S. Time-series forecasting with deep learning: a survey. **Philosophical Transactions of the Royal Society A**, v. 379, p. 20200209, 2021. Formatted: Justified
15. OMAR, M. S.; KAWAMUKAI, H. Prediction of NDVI using the Holt-Winters model in high and low vegetation regions: a case study of east Africa. **Scientific African**, v. 14, p. e01020, 2021. Formatted: Justified
16. SAINI, T.; CHATURVEDI, P.; DUTT, V. Modelling particulate matter using multivariate and multistep recurrent neural networks. **Frontiers in Environmental Science**, p. 614, Formatted: Justified

2021.

- | 17. AHMAD, R. et al. A machine-learning based ConvLSTM architecture for NDVI forecasting. **International Transactions in Operational Research**, 2020.
- | 18. REDDY, D. S.; PRASAD, P. Prediction of vegetation dynamics using NDVI time series data and LSTM. **Modeling Earth Systems and Environment**, v. 4, p. 409-419, 2018.
- | 19. FERCHICHI, A. et al. Forecasting vegetation indices from spatio-temporal remotely sensed data using deep learning-based approaches: A systematic literature review. **Ecological Informatics**, p. 101552, 2022.
- | 20. HUSSAIN, M.; MAHMUD, I. pyMannKendall: a python package for non parametric Mann-Kendall family of trend tests. **Journal of Open Source Software**, v. 4, p. 1556, 25 jul. 2019. ISSN ISSN: 2475-9066. Disponivel em: <<http://dx.doi.org/10.21105/joss.01556>>.
- | 21. MUTANGA, O.; KUMAR, L. Google Earth Engine Applications. **Remote Sensing**, v. 11, 2019. ISSN ISSN: 2072-4292. Disponivel em: <<https://www.mdpi.com/2072-4292/11/5/591>>.

Formatted: Justified

Formatted: Justified

Formatted: Justified

Formatted: Justified

Formatted: Justified