

Original Research Article

SIMULATION AND CONSTRUCTION OF A SOLAR POWERED SMART IRRIGATION SYSTEM USING INTERNET OF THINGS (IoT), BLYNK MOBILE APP

ABSTRACT

Aims: To simulate and construct a solar powered smart irrigation system using Blynk Mobile App.

Study design: Experimental design through simulation studies and internet of things.

Place and Duration of Study: Department of Physics, Nasarawa State University Keffi, Nigeria, between July 2021 and March 2022.

Methodology: The system was simulated using Proteus ISIS Version 8.6. It consists of two main units that is transmitter and receiver. The transmitter consists of a sensor circuit that senses the soil moisture, humidity and temperature. Then the Node MCU microcontroller collects the data and sent to the Blynk Mobile App (Receiver). The circuit was tested at two different conditions of the soil; Wet soil and Dry soil.

Results: Output performance analysis when the water level in soil (Moisture) was high, indicated Temperature value 28.3°C, Humidity 72%, and the Pump was OFF. When the water level in soil was mild, temperature was 60°C, Humidity 68%, and pump was turned ON. The pump is activated to switch ON as far as the water reservoir is having enough water and will switch OFF when the required level of moisture in the soil is achieved. The solar power ensured constant power supply, while the Blynk Mobile App ensured real time data monitoring by the Farmer even when he is far away from the farm.

Conclusion: This system is an improve irrigation system that supports low water and electricity consumption as well as efficient monitoring for increase farmers' output.

Keywords: *Smart irrigation; internet of things; BLYNK mobile app; solar power; simulation; construction.*

1. Introduction

Water and food are the basic necessities for human survival. Along with several environmental concerns and climate change, water scarcity and food security are growing concern in today's society. Agricultural practice plays a major role in providing food for the society and economic development of a country. Most agricultural practice depends universally on rainfall which is not a dependable source of water. Therefore, for farming to take place all through the year irrespective of the season there is need for an easy and less expensive irrigation system to improve conventional agriculture for a better productivity [1]. Over the years, different methods of irrigation has been developed to ease farming during scarcity of rainfall. Some of these methods either make the crops consume lots of water or dry them up because water could not reach them as at when due. Appropriate soil water level is a necessary pre-requisite for optimum plant growth. Also, water being an essential element for life sustenance, there is the necessity to avoid its undue usage. Irrigation is the artificial application of water to the soil. It is used to help cultivate agricultural crops, gardening, landscaping and wetting of dry soil during periods of inadequate rainfall or absence of it [2]. Irrigation remains the biggest water usage globally but also creates a lot of water wastage. Automated irrigation systems could reduce the use of water by making water drips slowly to the roots of the plants, either onto the surface of the soil or directly onto the root zone thereby saving a large quantity of water which comes to the plant [1]. Irrigation depends on the type of soil and where it is needed as such, the field should neither be over-irrigated nor under-irrigated [3].

Bulk of the existing irrigation systems employ the use of micro-processor based systems. These systems offer several technological advantages but are unaffordable, bulky, difficult to maintain and less accepted by the technologically unskilled workers in the rural set-up [3]. The Internet of Things (IoT) such as Blynk App is transforming the Agriculture industry and enabling farmers to contend with the enormous challenges they face. The global irrigation situation is classified by redoubled demand for higher agricultural productivity, poor performance and decreased accessibility of water for Agriculture [2]. These issues are befittingly corrected if we have a tendency to use machine-controlled system for irrigation. Automating farm or nursery irrigation permits Farmers to use the correct quantity of water at the correct time. It solely permits the user to observe and maintain the wetness level remotely in no matter of time. From the purpose of reading and performing at remote places the developed microcontroller primarily based irrigation system will work perpetually for indefinite fundamental measure, even in sure abnormal circumstances [2]. Using renewable resources and IoT technology, it can generate a sustainable and responsible conservation system over time. The Solar-Powered Smart Irrigation System aims to provide an IoT solution in automating the watering process using an Arduino-based microcontroller and sensors. It is an energy efficient and eco-friendly system that generates electricity from the photovoltaic cells to supply water to the plants [4]. The watering process is driven by the moisture content of the soil using sensors. Threshold limit are set for soil moisture sensor to ensure efficient and effective use of water resource. The main microcontroller unit controls the system whenever the sensor is across threshold value. Also, the system has built-in temperature and humidity sensors to monitor the climate condition on the specific environment. Another sensor is implemented to measure the water tank level which serves as storage capacity that supplies the water to the system. With the integration of IoT, automated irrigation can be easily access and remotely monitored over the mobile application through a wireless communication device. With these smart irrigation techniques, it replaces the traditional irrigation system that helps decrease the manual intervention and mistakes [5].

The objective of this study is to simulate and construct a solar powered smart irrigation system using Blynk Mobile App communication technology for system automation and monitoring. In order to replace expensive controllers in current available systems, the Node Microcontroller Unit (Node MCU) was used in this project as it is an affordable microcontroller. The Node MCU was programmed to analyze some signals from sensors such as moisture, temperature, and humidity. The use of easily available components reduces the manufacturing and maintenance costs. This makes the proposed system to be an economical, appropriate and a low maintenance solution for applications, especially in rural areas and for small scale Agriculturists. It will help the small-scale farmers which will increase the yield of their crops likewise improve the economy of the country.

2. Materials and Methods

2.1 Materials

The materials used in this research work includes 12V, 10A solar panel, ESP8266 Node MCU microcontroller, 12V water pump, soil moisture sensor, 5V, 10A relay, 12V, 10A charge controller, 5V, 0.3mA DHT 11 (temperature and humidity sensor), buck converter (DC-DC), window 10 laptop computer, and simulating software (Proteus 8.6).

2.2 Methods

The method used in this study is into two parts; software design method and hardware design method. The software component involves circuit simulation, flow charts, and algorithms, while the hardware part includes constructing the prototype and testing the system to verify correct functionality.

2.2.1 Software Design Method

2.2.1.1 Circuit Simulation Method

The simulation was carried out using Proteus ISIS (8.6 Version) to replicate the system's real-world operation over time. This was carried out to predict the behavior of the system and determine what to do to influence the behavior if not acting as proposed before constructing the prototype. The stages included in the simulation are the Moisture sensor unit, the DHT 11 unit, the Node MCU, the Relay, the pump and the power supply unit. This is done according to the block diagram in Fig. 1.

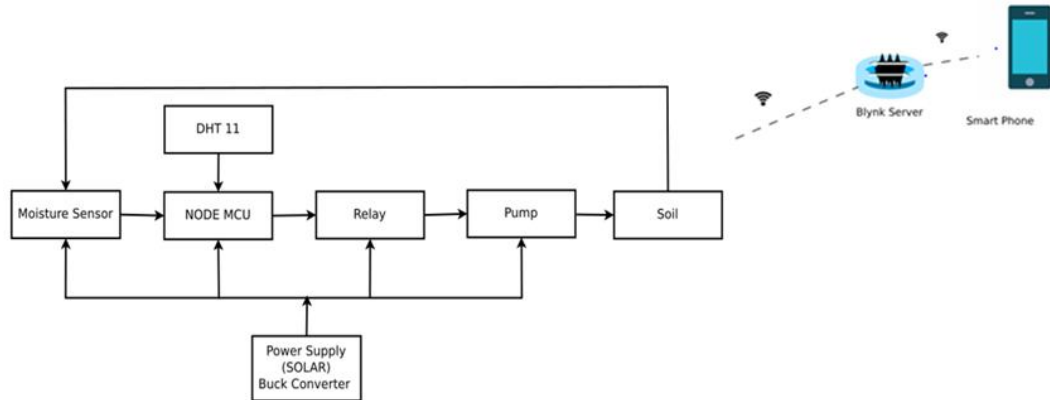

Fig. 1. Block Diagram of the System

2.2.1.2 Proteus ISIS

Proteus is a design software developed by Lab Center Electronics for electronic circuit simulation, schematic capture and PCB design. Its simplicity and user-friendly design made it popular among electronics hobbyists. Proteus is commonly used for digital simulations such as microcontrollers and microprocessors. It allows engineers to run interactive simulations of real designs for circuit simulation. It has a range of simulator models for popular micro-controllers and a set of animated models for related peripheral devices such as LED and LCD displays, keypads and more. It is possible to simulate complete microcontroller systems and thus to develop the software for them without access to a physical prototype [6].

2.2.1.3 Choice of Programming Language

According to Soulé *et al.* [7], the choice of programming language must be available on a wide set of platforms, the implementation of the chosen language must be generally acknowledged and available, compilers producing highly optimized codes are also required. This programming language could be Java, C, Embedded C and C++ etc. The widely used programming language for embedded microcontrollers is C language and which we also used in this research.

2.2.1.4 Flowchart

The flow chart for the Solar Powered Smart Irrigation System using IoT through Blynk Mobile App is shown in Fig. 2. This was used to create an algorithm for developing the language code (C++) for the system operation.

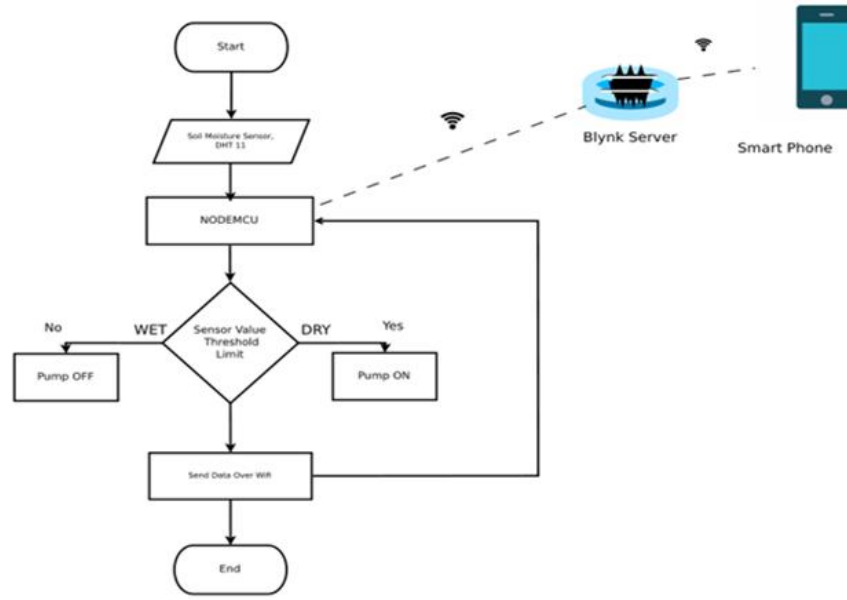

Fig. 2. Flowchart of solar powered smart irrigation system

2.2.1.5 The Algorithm

The algorithm that explains the flow chart for the Solar Powered Smart Irrigation System using IoT through Blynk Mobile App is as follows;

1. Start
2. System Initializing
3. Is the soil DRY?
4. If YES, send signal to Node MCU
5. Node MCU energizes the relay to turn ON the Pump
6. If NO, turn OFF the Pump
7. Send Feedback to Node MCU
8. Node MCU send Data over the Internet to Blynk App

2.2.2 Construction Method

Following the block diagram in Fig. 1, the system was built in stages. The components were built on an electrical breadboard to check good terminal connections before being transferred to a Printable Circuit Board (PCB) and soldered using a soldering iron and 1mm wire lead solder. The stages includes temperature and humidity sensor, the moisture sensor, the pump unit, and all other system components are interfaced with the microcontroller and Arduino board.

2.2.2.1 Solar Panel (Power Unit)

The power supply unit of the system is through the use of solar energy. Solar energy works by capturing the sun's energy or photons and turning it into electricity for the home or business use. Solar technology is improving and the cost of going solar is dropping rapidly, so our ability to harness the Sun's abundance

of energy using photovoltaic (PV) solar panels to generate direct current is on the rise. The circuit of the solar power supply is shown in Fig. 3.

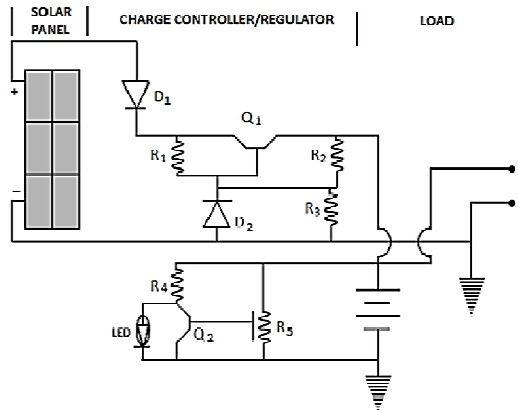

Fig. 3. Circuit diagram of the solar power supply [8]

2.2.2.2 The Node MCU (Node Microcontroller Unit)

It is an open-source software and hardware development environment that is built around a very inexpensive System-on-a-Chip (SoC) called the ESP8266. The ESP8266, designed and manufactured by Espressif Systems, contains all crucial elements of the modern computer: CPU, RAM, networking (Wi-Fi), and even a modern operating system. The versatility of the Node MCU makes it an excellent choice for IoT projects of all kinds. It has two key components; open source ESP8266 firmware and DEVKIT board.

i. The Open Source ESP8266 Firmware: This is built on top of the chip manufacturer’s proprietary SDK. The firmware provides a simple programming environment based on eLua (embedded Lua), which is a very simple and fast scripting language with an established developer community. For new comers, the Lua scripting language is easy to learn.

ii. The DEVKIT Board: This incorporates the ESP8266 chip on a standard circuit board. The board has a built-in USB port that is already wired up with the chip, a hardware reset button, Wi-Fi antenna, LED lights, and standard-sized GPIO (General Purpose Input Output) pins that can plug into a bread board. Fig. 4 shows the DEVKIT board, and the schematic pin configuration.

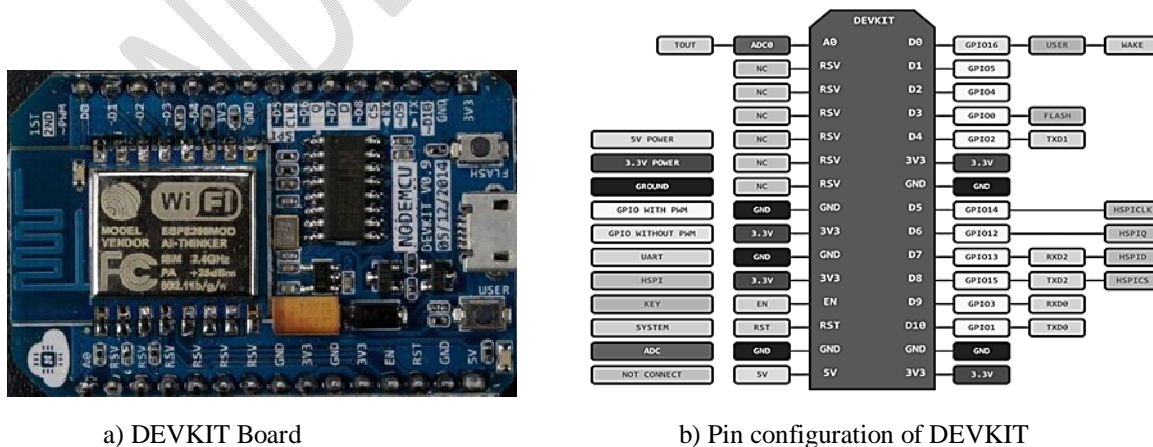

a) DEVKIT Board

b) Pin configuration of DEVKIT

Fig. 4. Node Microcontroller Unit DEVKIT Board and pin configuration [9]

2.2.2.3 Soil Moisture Sensor

This is an electrical resistance sensor. It is made up of two electrodes that reads the moisture content around it. When a current is passed across the electrodes through the soil, the resistance to the current in the soil determines the soil moisture. This is a conversion of change in resistance to change in voltage. If the soil has more water, resistance will be low and thus more current will pass through i.e. increase conductivity. On the other hand, when the soil moisture is low, the sensor module outputs a high level of resistance [9, 10]. Therefore, it gives a voltage output corresponding to the conductivity of the soil and the conductivity of soil varies depending upon the amount of moisture present in it. In this study, the moisture sensor which can be inserted in the soil to measure the moisture content of the soil was used and the soil was examined under three conditions; dry condition, optimum condition and excess wet condition.

2.2.2.4 Water Pump

The water pump is used to artificially supply water for a particular task. It can be electronically controlled by interfacing it to a microcontroller. It can be triggered ON/OFF by sending signals as required. This project employs the use of a small water pump.

2.2.2.5 Relay

Relays are switches and thus terminologies applied to switches are also applied to relays. A relay switches one or more poles, each of whose contacts can be thrown by energizing the coil in one of three ways namely; normally open (NO), normally closed (NC) or change over (CO). Just like manual switches, the relay switch part is available in various configurations. The Double Pole, Double Throw (DPDT) configuration is most common configuration and was used in this study. DPDT means that the relay separately controls two switches that work together. Both switches have a normally NO and NC contacts.

2.2.2.6 Digital Temperature and Humidity Sensor (DHT11)

The DHT11, digital temperature and humidity sensor is a composite sensor that incorporates a calibrated digital temperature and humidity signal output. The temperature and humidity sensor technology, as well as specific digital module collection technology, are used to ensure that the component has a high dependability and long-term stability. A resistive sense of wet component and an NTC temperature measurement device are included in the sensor, which is connected to the Node MCU.

2.2.3 Testing Method

The test that were carried out after construction of the circuit includes continuity test and performance evaluation test. The continuity test was carried out to ensure proper current flow in the circuit so as to prevent open circuits along the path and the removal of bugs in the circuit. This was carried out using the multimeter. The performance evaluation test was carried out to ascertain the functionality of the constructed system. The test was carried out at two different conditions of the soil; Wet soil and Dry soil.

3. Results

3.1 Simulation Results

The simulation of the circuit was carried out in stages according to the block diagram shown in Fig. 1 and the results are presented in Fig. 5 to 7. Fig. 5 shows simulated general circuit, while Fig. 6 is the simulated general circuit displaying the virtual terminals and Fig. 7 is virtual terminals indicating the soil conditions.

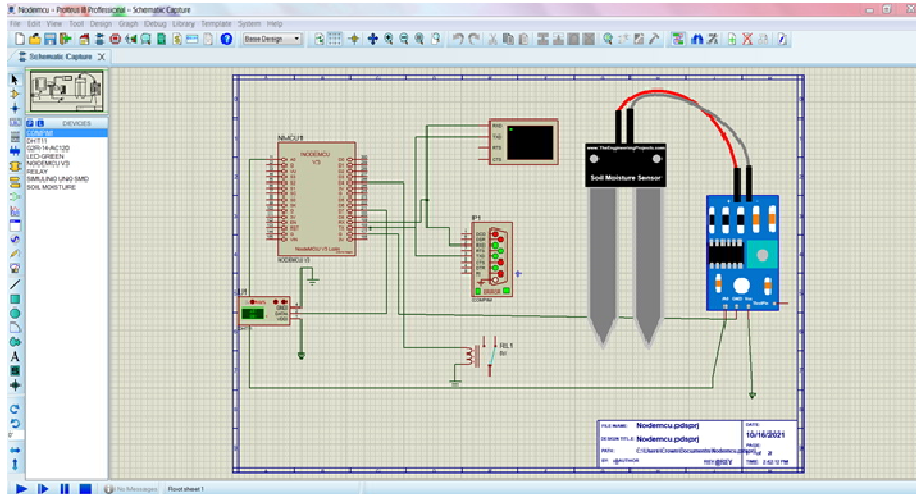

Fig. 5. Simulated result of the complete circuit

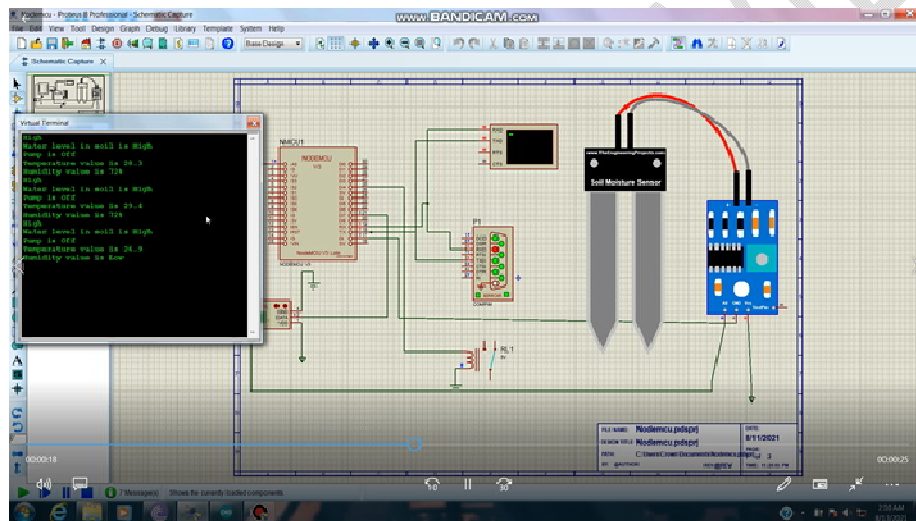

Fig. 6. Simulated result of the circuit with virtual terminals

```

Virtual Terminal
High
Water level in soil is High
Pump is Off
Temperature value is 28.3
Humidity value is 72%
High
Water level in soil is High
Pump is Off
Temperature value is 29.4
Humidity value is 72%
High
Water level in soil is High
Pump is Off
Temperature value is 26.9
Humidity value is Low
Mild
Water level in soil is Mild
Turning on Pump
Temperature value is 60%
Humidity value is 68%
    
```

Fig. 7. Virtual terminals displaying soil conditions

This system works in such a way that when the Solar Panel charges the battery, there is a charge controller connected between the solar panel and the battery which regulates the rate of battery charging to avoid over charging. The solar panel is 10W, 12V while the Charge controller is 10A, 12V. The buck converter connected to the battery steps the 12V down to 5V because the microcontroller works with 5V. The buck converter is regulated from 12V to 5V so as to power the microcontroller. There's a moisture sensor probe connected to the microcontroller and then to the soil. The sensor checks the moisture condition of the soil if wet or dry. When the soil is dry, it sends signal to the microcontroller, and then the microcontroller triggers the relay which in turn switches the water pump ON. There's another buck converter between the relay and the pump which regulates the flow rate of the pump. Also, a DHT 11 is connected to the microcontroller to check humidity and temperature of the environment where the plants to be irrigated are grown. The Wifi Module, Node MCU ESP8266 send commands to the smartphone wirelessly through the internet. To encode the ON/OFF signal and send it to Server and to ESP8266 Board, Blynk Mobile Application was used, being the best IoT platform available presently.

3.2 Construction

The circuit was built on a breadboard first to confirm that everything worked properly, and then transferred to the PCB for permanent soldering. The sensor, the relay unit, and all other components in the system were interfaced with the Node MCU and Arduino board. To avoid awkwardness and bridging of the components, too much Lead was avoided. The top and side views of the constructed solar powered smart irrigation circuit are shown in Fig. 8.

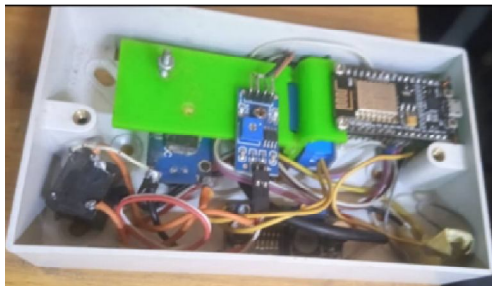

a) Top view of constructed circuit

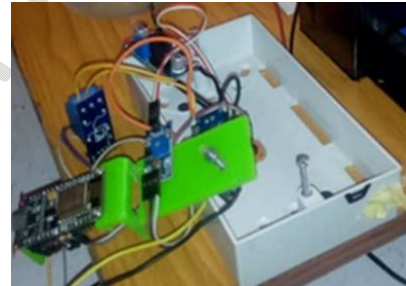

b) Side view of constructed circuit

Fig. 8. Constructed solar powered smart irrigation circuit

4. Testing Analysis

4.1 Continuity Test

The purpose of a continuity test is to see if current flows in an electric circuit. A tiny voltage (wire in series with an LED or a speaker) is applied to the chosen path to perform the continuity test. The circuit is "open" if broken conductors, damaged components, or excessive resistance prevent electron flow. A multimeter was used for this test. The multimeter was set to continuity mode, and the two ends of the probe were placed at the ends of a specific wire that was being examined for continuity. If there is no resistance between the ends of the wire or path, or the multimeter buzzer sounds, the ends or path is continuous. This test was carried out after the hardware had been soldered and configured.

4.2 Performance Evaluation Test

The purpose of the performance evaluation test was to determine the functionality of the constructed system. The test was carried out at two different conditions of the soil; Wet soil and Dry soil. When the water level in soil (Moisture) was high, Temperature value was 28.3°C, Humidity value was 72%, and the Pump was OFF. When the water level in soil was mild, temperature value was 60°C, Humidity value was 68%, and pump was turned ON. This was displayed in the virtual terminal as shown in Fig. 7.

4.3 Blynk Application Setup

In this study, all the control is done by the Blynk Application. Blynk is a Platform with IOS and Android apps to control Arduino, Raspberry Pi, and the likes over the Internet. It's a digital dashboard where we can build a graphic interface for electronics projects by simply dragging and dropping widgets. Blynk Application was downloaded and installed from Play Store being an Android User. It can also be downloaded from App Store for iOS users. The Blynk IoT App is shown in Fig. 9.

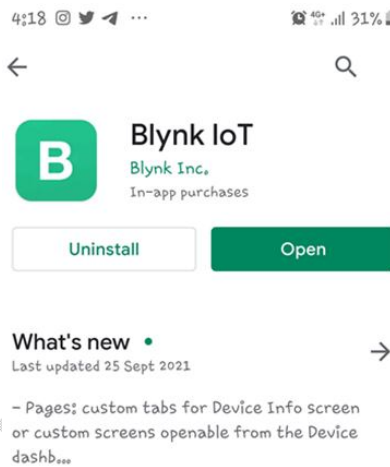

Fig. 9. Blynk Installation from App Store

To setup the Blynk App for Smart Irrigation System, we opened the application and created a new account using an Email identity (ID), then clicked on “New Project “. We followed the images in Fig. 10 and 11 for the complete setup guide.

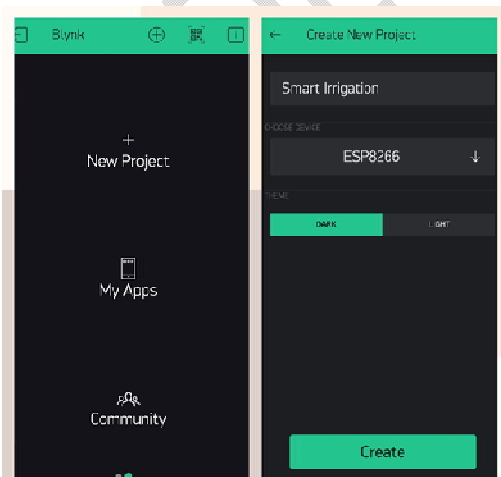

Fig. 10. Blynk Application Setup guide

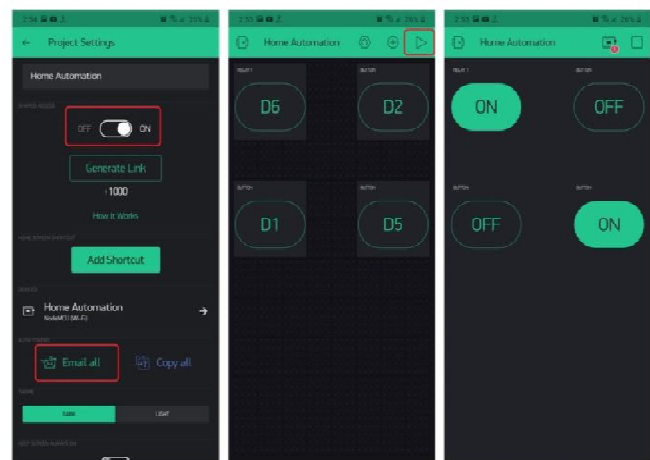

Fig. 11. Blynk App Installation Setup

IoT. But the design is quite different from that of Harishanka *et al.* [14] who carry out a study on solar powered smart irrigation system in India without incorporating IoT monitoring platform, Moon *et al.* [15] and Singh *et al.* [16] who presented a solution for an irrigation controller for cultivation of vegetable plants based on the fuzzy logic methodology. Also, not in line with the works of Wang *et al.* [17] and Navarro *et al.* [18] as their works did not involve construction of automatic device but only reviewed the Applications of the Internet of Things (IoT) for Agricultural Automation and smart irrigation.

8. Conclusion

In this study, a solar powered smart irrigation system using Internet of Things was simulated and constructed. Parameters such as moisture, temperature and humidity levels were monitored. All these were displayed via Blynk mobile Application. The results from the performance test of the constructed circuit agreed with the specification of the simulation outcome. The simulated smart irrigation system supports low water consumption because the water usage is being controlled and monitored automatically. This system also makes it easy for effective monitoring of the irrigation activities on the farm. Thus the system will only work effectively with the presence of internet on the Farm and on the Farmer's location.

Consent: As per international standard or university standard, respondents' written consent has been collected and preserved by the author(s).

Ethical Approval: It is not applicable.

REFERENCES

- [1] Hade AH, Sengupta MK. Automatic control of drip irrigation system & monitoring of soil by wireless. *Journal of Agriculture and Veterinary Science*. 2014;7(4):57–61.
- [2] Burton M. Water management issues at the farm level. In *Indian Irrigation Forum International Commission on Irrigation and Drainage (ICID) India Water Week*; 2016:1-19.
- [3] Patel AS, Agrawal A, Al-Amery AH. Smart irrigation system. *International Journal of Current Engineering and Scientific Research (IJCESR)* 2016;3(3):2394-0697.
- [4] Thakur DS, Sharma A, Sharma DK. A low cost design & monitoring of automatic irrigation system based on zigbee technology. *Int. J. Eng. Res. Technol.* 2013;2(5):1112-1121.
- [5] UK Essay. Solar Powered Smart Irrigation Monitoring System Using Iot. 2020. Accessed 15 October 2021. Available: [https://www.ukessays.com > Information-Technology](https://www.ukessays.com/information-technology).
- [6] Electrosome. Getting started with Proteus for Beginners. 2013. Accessed 10 October 2021. Available: <https://electrosome.com/getting-started-with-proteus-beginners-tutorial/>.
- [7] Soulé R, Gordon MI, Amarasinghe S, Grimm R, Hirzel M. Dynamic expressivity with static optimization for streaming languages. In *Proceedings of the 7th ACM international conference on Distributed event-based systems*. 2013;159-170. <https://doi.org/10.1145/2488222.2488255>.
- [8] Bello SR. Circuit diagram of the solar power supply. Message posted to research gate. 2012. Accessed 10 October 2021. Available: <https://www.researchgate.net/figure/circuit>.
- [9] Tooley M. *Electronic Circuits: Fundamentals and Applications*. 3rd ed. London: Routledge; 2007. Available: <https://doi.org/10.4324/9780080477503>.

- [10] Horowitz P, Hill W. The art of electronics. 2nd ed. Cambridge New York: Cambridge university press; 1989.
- [11] Verma A, Kumar A, Sikarwar A, Sahu A. Automatic Irrigation System Using DTMF. In National Conference on Synergetic Trends in Engineering and Technology, IJETR; 2014.
- [12] Balaji VR. Smart irrigation system using IoT and image processing. International Journal of Engineering and Advanced Technology (IJEAT). 2019;8(6S):115-120.
- [13] Bhuvanewari P, MG P. Smart indoor vertical farming monitoring using IoT. Journal of Contemporary Issues in Business and Government. 2021;27(3):1741-1753.
- [14] Harishankar S, Kumar RS, Sudharsan KP, Vignesh U, Viveknath T. Solar powered smart irrigation system. Advance in Electronic and Electric Engineering. 2014;4(4):341-346.
- [15] Moon A, Kim J, Zhang J, Son SW. Evaluating fidelity of lossy compression on spatiotemporal data from an IoT enabled smart farm. Computers and Electronics in Agriculture. 2018;154(1):304-313. <https://doi.org/10.1016/j.compag.2018.08.045>.
- [16] Singh A, Agrawal M. Effects of waste water irrigation on physical and biochemical characteristics of soil and metal partitioning in Beta vulgaris L. Agricultural Research. 2012;1(4):379-391. <https://doi.org/10.1007/s40003-012-0044-4>.
- [17] Wang E, Attard S, Linton A, McGlinchey M, Xiang W, Philippa B, Everingham Y. Development of A Closed-Loop Irrigation System for Sugarcane Farms using the Internet of Things. Computers and Electronics in Agriculture. 2020;172(1):105376. <https://doi.org/10.1016/j.compag.2020.105376>.
- [18] Navarro E, Costa N, Pereira A. A systematic review of IoT solutions for smart farming. Sensors. 2020;20(15):4231. <https://doi.org/10.3390/s20154231>.