

Thermal Error Analysis of Machine Tool Spindle Based on BP Neural Network

Abstract: With the continuous improvement of the accuracy of machine tools, the proportion of the thermal error of machine tools in the total error is increasing. In this paper, the thermal error of horizontal machining center is analyzed by finite element simulation, a three-dimensional model is established in SolidWorks, and some details (such as bolt holes) are simplified and imported into ANSYS Workbench to determine the heat generation model, heat dissipation model, convection heat transfer coefficient and other boundary conditions. On the basis of the temperature field, the thermal-structural coupling analysis is carried out, and the temperature cloud field of the whole machine tool is obtained through the analysis, which provides a theoretical basis for the experimental design. Then, the data are divided into four categories by fuzzy cluster analysis, and finally, the thermal error model is established by BP neural network based on time series. It provides a theoretical reference for the compensation of thermal error.

Keywords: machine, tool spindle, thermal error analysis, BP neural network, finite element analysis

0 Introduction

CNC machine tools cover traditional machine tools, electronic control technology, measurement technology, precision machining, etc. With the continuous improvement of machine tool precision, the influence of thermal error is increasing. In precision machine tools, thermal error can account for about 70% of the total error [1], and the higher the precision of the machine tool, the greater the proportion of thermal error. CNC machine tools are the mother machines of industry, and the production and processing of all kinds of products are inseparable from machine tools. Now, machine tool intelligent control system [2] is an important part of intelligent machine tool field in the future, and key technologies such as artificial intelligence technology, digital twin technology and cloud service will be the future development direction. Jorgensen et al. [3] established a comprehensive thermal error model of high-speed motorized spindle. In this model, the coupling analysis of bearing and spindle model was carried out by using lumped mass method, and the thermal steady state of motorized spindle under different lubrication modes was analyzed. The model provides a good choice for spindle design and optimization. Mian[4] simulated and analyzed the thermal characteristics of the machining center based on finite element simulation. Yang et al. [5] of the University of Michigan adopted the neural network algorithm, trained the experimental data, and processed the thermal error model of the whole machine in the machining center, which was more accurate. Domestically, Huang Lin [6] of Shanghai Jiaotong University studied the domestic horizontal machining center with double spindles, established a thermal characteristic model based on the principles of heat transfer and mechanics, obtained the thermal characteristics through finite element simulation, and then optimized the machining center to verify the accuracy of the thermal characteristic model. Yin Ling

[7] studied the robust compensation method of machine tool thermal error and the embedded integration of thermal error compensation in numerical control system.

The research object of this paper is a horizontal machining center, which mainly takes milling and drilling as the machining mode, and belongs to the mainstream type of machine tools. Studying the thermal error of this machine tool is of the same significance to similar models. With the continuous improvement of production needs, the accuracy of the machine tool is also constantly improved, and various optimization schemes of the machine tool emerge in endlessly. This paper mainly analyzes the thermal error of the machine tool.

At present, with the improvement of production automation, the precision of machine tools at home and abroad has been continuously improved, and the thermal error of machine tools has been paid more and more attention [8-9]. There are many sources of thermal errors in machine tools, and the errors caused by heat can't be avoided. In terms of modeling methods, the thermal error modeling of machine tools can be divided into two categories. One is empirical thermal error modeling, which mainly collects information (temperature, time, etc.) of each data point of machine tools, then identifies the thermal key points based on statistical models, and then makes corresponding compensation by modeling. The other is the theoretical thermal error modeling method, which is a differential equation based on heat transfer and constraints of force and displacement, and the thermal deformation is solved by solving the solution of the differential equation. In recent years, with the rapid development of computer technology, theoretical thermal error modeling method has been widely used.

1 the establishment of three-dimensional model

According to the two-dimensional drawings, build a three-dimensional model, and then assemble each part, as shown in Figure 1. The structure of the horizontal machining center mainly includes lathe bed, cross slide table, upright post, spindle box and other parts. The structure of machining center is complex and there are many parts. If the complete model is directly imported, it will be difficult to define the contact and solve it. In order to prevent the stress distortion of the model in finite element analysis, on the basis of ensuring that the calculation accuracy is not affected, the small structures such as bolt holes, chamfers and fillets in the three-dimensional model are simplified into entities. The simplified model is imported into ANSYS Workbench, and the contact surface is set as friction contact, which is convenient for heat transfer.

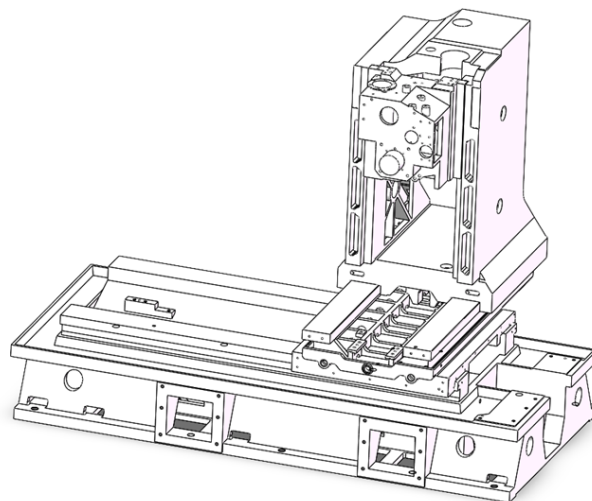

Figure 1 Three-dimensional model diagram of horizontal machining center

ANSYS Workbench integrates various grid generation methods, such as tetrahedron generation method, sweeping generation method, etc. This design adopts the method of automatic grid division, and the program will automatically select the best division method according to the structural characteristics. Set the cell size to 20mm, generating a total of 766,083 nodes and 432,829 cells. The division effect is shown in Figure 2.

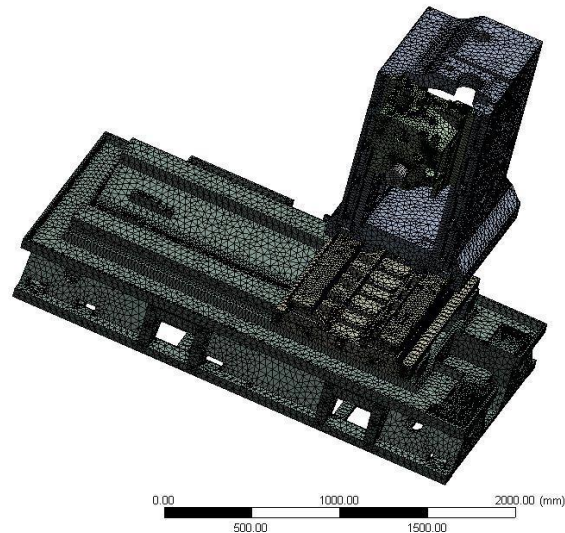

Figure 2 Grid diagram of horizontal machining center

Horizontal machining center is mainly composed of key parts such as bed, upright post, slide table, spindle, spindle box, etc. The movement between bed and slide table and between slide table and upright post is realized by ball screw feeding, which has the advantages of low friction coefficient and high transmission accuracy. The materials and mechanical properties of machine tools are shown in Table 1.

Table 1 Material Properties and Mechanical Properties

material	Elastic modulus Gpa	Density/m ³	Poisson's ratio	Specific heat capacity J/(kg*°C)
HT300	130	7300	0.25	460
45 steel	210	7850	0.3	434

2. Establishment of thermal characteristic model of machine tool.

2.1 heat transfer theory

When the machining center is machining, a large amount of heat will be generated due to the high-speed rotation of the spindle, and the bearing will also generate huge heat, as well as other heat sources. These heat will be transferred through the machine tool parts, thus making the temperature of each machine tool part different, and then causing tiny deformation, which is the reason for the heat transfer deformation of the machine tool. Usually, heat transfer can be divided into two categories, one is generalized heat transfer, and heat is transferred around us all the time. For example, computer heat is transferred to the air, and heat transfer is a science to study the basic law of heat transfer. The other is heat transfer in a narrow sense, which refers to the process of heat transfer between the hot fluid through the wall of a solid object and the cold fluid around the object. Therefore, heat transfer is a science that studies the way and speed of heat transfer. Heat transfer can be divided into three types: conductive heat transfer, convective heat transfer and radiative heat transfer.

1. heat conduction

Suppose the area of a flat plate is A , the thickness is L (m), and the temperatures on the left and right sides of the flat plate are T_1 and T_2 (K), respectively. The amount of heat transferred by heat conduction is:

$$\dot{Q} = Ak \frac{T_1 - T_2}{L} \tag{1}$$

Where k is the thermal conductivity, and the heat transfer per unit area is the heat flux Q , where the temperature gradient of the flat plate is $k(W/(m * K))q = \dot{Q}/A(W/m^2)$

$$\frac{dT}{dx} = \frac{T_2 - T_1}{L} \tag{2}$$

Therefore, the heat flux caused by heat conduction

$$q = -k \frac{dT}{dx} \tag{3}$$

This formula is a one-dimensional expression of Fourier law of heat conduction. The thermal conductivity k is a physical property, or thermophysical property, determined by the state of a substance such as its temperature and composition. On the premise of the same temperature gradient, the greater the thermal conductivity, the greater the heat transfer caused by heat conduction of the material. The thermal conductivity of different substances can vary greatly.

2. Thermal convection

Suppose the surface area of an object is A , the temperature is T_1 , and there is a fluid flowing around it with the temperature of T_2 . Because there is a temperature difference between the object and the surrounding air, convective heat transfer occurs. Around the object, there is a boundary layer whose temperature and velocity change. At this time, the relationship between heat transfer and temperature difference can be expressed by the following formula:

$$\dot{Q} = Ah(T_1 - T_2) \tag{4}$$

Where $h(W/m^2 * K)$ is the heat transfer coefficient. The heat transfer coefficient is different from the heat transfer coefficient, which is the inherent property of a substance, and changes with the flow rate and temperature of the fluid. If the area is dA (m²), the heat transfer amount is local heat flux density, and the relationship with the temperature difference can be expressed as $d\dot{Q}(W)q = d\dot{Q}/dA$

$$q = h(T_1 - T_2) \tag{5}$$

This formula is called Newton's cooling law.

Convection can be divided into natural convection and forced convection, in which natural convection refers to the buoyancy caused by the increase of fluid temperature and the decrease of fluid density, which leads to a certain convection. Forced convection refers to forced convection by external blowing or pump.

3. Thermal radiation

Every object has a certain temperature. Because of the existence of temperature, the object will radiate heat. Assuming that the temperature of an object is T (K), the thermal radiation per unit area is

$$E_b = \sigma T^4 \tag{6}$$

Where σ is the Stefan-Boltzmann constant. It is the blackbody emissivity, that is, the heat flux density of blackbody radiation. In this paper, the influence of thermal radiation is relatively small, so the thermal radiation is not analyzed. $\sigma(W/m^2 * K^4)\sigma = 5.67 * 10^{-8}W/(m^2 K^4)E_b(W/m^2)$

2.2 heat generation model

1 bearing heat generation model

In horizontal machining centers, the bearings are mainly rolling bearings, and the heat generated by the bearings mainly comes from the friction between the rolling elements and their contact surfaces. The heat generation of the bearing is related to the type of bearing, the type of lubricant, the rotating speed, etc. According to the empirical formula, the heat generation of the rolling bearing can be calculated by the following formula.

$$Q = 1.05 * 10^{-4} * M * n \tag{7}$$

Q is the heat generation of the rolling bearing, M is the total friction torque of the bearing, and N is the rotating speed of the bearing. Total bearing friction torque m includes viscous friction torque and rolling friction torque.

1) The viscous friction torque is caused by the viscous force of lubricant, and the calculation formula is as follows:

$$M_0 = \begin{cases} 10^{-7} f_0 (vn)^{2/3} D_m^3 & (vn > 2000 \text{cst} * r/min) \\ 160 \times 10^{-7} f_0 D_m^3 & (vn < 2000 \text{cst} * r/min) \end{cases} \tag{8}$$

Type-coefficient related to bearing type and lubrication mode, as shown in Table 2, f_0

—Diameter of bearing pitch circle, unit (mm) D_m

—kinematic viscosity, in mm²/sv

N— bearing speed, in r/min.

Table 2: Type-coefficient related to bearing type and lubrication mode

Bearing type	Oil injection	Grease lubrication	mist lubrication
axial contact ball bearing	0.7-1	1.5-2	3-4
Single row radial ball bearing	0.7-1	1.5-2	3-4
single file/row	1	2	4
biserial	2	4	8

2) Rolling friction torque is calculated by the following formula.

$$M_1 = f_1 P_1 D_m \tag{9}$$

Among them,

$$P_1 = f_p (X F_r + Y F_a) f_1 = x (P_0 / C_0)^y \tag{10}$$

Type-impact load coefficient f_p

P_0 -equivalent static load of bearing;

C_0 -rated static load of bearing

F_r -bearing radial load

F_a -bearing axial load

P_1 、 f_1 The calculation can refer to Table 3.

Bearing type	f_1	P_1
axial contact ball bearing	$0.0012 (P_0 / C_0)^{0.88}$	$\max(F_a, 2.3 F_r \tan \alpha + F_a)$
Single row radial ball bearing	$0.0009 (P_0 / C_0)^{0.55}$	$3 F_a - 0.1 F_r$
single file/row	$0.0013 (P_0 / C_0)^{0.88}$	$F_a - 0.1 F_r$
biserial	$0.001 (P_0 / C_0)^{0.88}$	$1.4 F_a - 0.1 F_r$

2. Heat generation model of screw nut

Ball screw is an important part of machine tool. Ball screw has the characteristics of high speed and high precision, and its heat mainly comes from friction heat generated by balls and environmental temperature. As the increase of heat leads to the deformation of the ball screw, the screw is a slender piece. Experience shows that when the temperature of the screw shaft rises by one degree Celsius, the elongation of the screw is about 0.012mm/m. For high precision machine tools, the error caused by temperature rise should not be underestimated. Therefore, the heat generation model of the screw nut is used to calculate the birth heat.

In this paper, the heat generation model of the screw nut is approximately equivalent to the heat generation of the bearing heat generation model plus the heat generation caused by the pre-tightening force of the screw nut, and the friction torque caused by the pre-tightening force of the screw nut is

$$M_p = \frac{F_p l(1-\eta^2)}{2\pi\eta} \quad (11)$$

Total friction torque is

$$M = M_0 + M_1 + M_p$$

Then, according to formula (7), the heat generation can be obtained.

3. Motor heat generation model

The mechanical structure of the spindle drive system of CNC machine tools has been greatly simplified. Traditional machine tools are driven by electric motor, belt drive and gear drive are used in the middle transmission, and modern CNC machine tools are mostly directly driven by built-in electric motor, commonly known as 'electric spindle'. This machine tool spindle motor adopts AC servo motor. The electric spindle has the advantages of compact structure, light weight, small inertia, small vibration, low noise and fast response.

The calculation formula of motor calorific value is:

$$Q = P(1 - \eta) \quad (12)$$

Where: P is motor power and motor efficiency. η

4. Heat generation model of guide rail slider

The heat generation of the guide rail mainly comes from the friction heat generation of the guide rail slider, and its heat generation model is:

$$Q = \mu F v \quad (13)$$

μ is the friction coefficient between guide rail and slider, f is the positive pressure between guide rail and slider, and v is the relative moving speed between slider and guide rail.

2.3 heat dissipation model

1. Natural convection heat transfer

Natural convection heat transfer is the thermal convection between the outer surface of the machine tool and the environment, which is the main heat dissipation mode of the machine tool. According to Nuschelt's criterion, the calculation method of heat transfer coefficient is: h

$$h = \frac{Nu^* \lambda}{L} \quad (14)$$

In this formula, Nu is Nuschert number, the thermal conductivity of the fluid, and l is the characteristic size. λ

The standard Nu-Serto criterion and Grachev equation for natural convection heat transfer are:

$$Nu = C(Cr \cdot Pr)^n \quad (15)$$

$$Gr = \frac{g\beta L^3 \Delta t}{\nu^2} \tag{16}$$

Where, C,n are constants, and the specific values are shown in Table 4. Gr is the Grashoff number, Pr is prandtl number, G is the acceleration of gravity, the bulk expansion coefficient of the fluid, L is the characteristic size, the temperature difference between the fluid and the wall, and V is the kinematic viscosity. $\beta\Delta t$

Table 4 C, value table of n

C	n	applicability	Heat exchange surface position	fluid state
0.59	1/4	$(Gr*Pr) \in [10^4, 10^9]$	Vertical wall	laminar flow
0.12	1/3	$(Gr*Pr) \in [10^9, 10^{12}]$	Vertical wall	turbulence
0.54	1/4	$(Gr*Pr) \in [10^5, 2 \times 10^7]$	The wall is horizontal and the hot side faces downward.	laminar flow
0.14	1/3	$(Gr*Pr) \in [2 \times 10^7, 3 \times 10^{10}]$	The wall is horizontal and the hot side faces upwards.	turbulence
0.27	1/4	$(Gr*Pr) \in [3 \times 10^5, 3 \times 10^{10}]$	The wall is horizontal and the hot side faces downward.	laminar flow

2. Forced convection of cooling water

Water-cooling device is used in the spindle, which can take away more heat. The calculation equation is:

$$Nu = 0.023Re^{0.8}Pr^{0.4} \tag{17}$$

$$Re = \frac{u*D}{\nu} \tag{18}$$

Where, U is the water flow velocity, in m/s, and D is the pipe diameter, in m.

The thermal conductivity of water is 0.54W/(m*k), the prandtl number Pr is 7, and the kinematic viscosity is 0.658 mm²/s. The diameter of the pipe is 8mm, and the cooling water flow rate is 5L/min. λ

3 Finite Element Analysis of Horizontal Machining Center

When the horizontal machining center is in operation, the heat source generated inside is transferred to different parts through heat transfer. At the same time, the components are also affected by gravity and contact force, and thermal-mechanical coupling occurs. Resulting in deformation of the final parts. Then it affects the machine tool-fixture-workpiece system, making the precision of machined parts lower. The steady-state thermal analysis module of AYSYS Workbench is used for analysis. Through the heat generation model and heat dissipation model, the boundary conditions of finite element simulation are calculated, and the steady-state temperature field distribution of the whole machine is solved. In order to get the influence of machining center heat on structural deformation, the static modules share the temperature results of steady-state thermal analysis by using the results of steady-state analysis, and the deformation under thermal-structural coupling is obtained.

3.1 Thermal characteristic model under simulation conditions

1. working condition setting

In order to find out the thermal deformation law in the simulation

environment, it is necessary to know what kind of working condition the machine tool is in. The horizontal machining center adopts FANUC numerical control system, which is a three-coordinate machining unit and supports 25 cutters. It can complete boring, drilling, milling, expanding, twisting, tapping and other machining processes, and is suitable for flexible machining production lines. See table 5 for specific working conditions.

Table 5 Working condition of horizontal machining center

Range of motion			Fast forward speed	Working speed	rotation speed	Maximum cutter diameter
X axis	Y axis	Z axis	X, y and z axes	X, y and z axes		
1100mm	500mm	600mm	24m/min	1-10000mm	3900rpm	110mm

Under this simulation condition, after consulting the empirical formula of machine tool cutting force calculation, it is calculated that the cutting force of the spindle connecting tool is $F_X=614N, F_Y=1660, F_Z=982N$.

3.2 Loading and Simulation of Thermal Boundary Conditions

The finite element thermal boundary conditions include heat generation constraint and heat dissipation constraint. There are six kinds of loads that can be applied to the finite element: temperature, heat flux, convective heat transfer, heat flux density, heat generation rate and thermal radiation rate, in which the heat generation rate is the heat generated by the object in unit unit of volume time or the heat generated by the surface of the object in unit area and unit time. These boundary conditions are loaded on the finite element, and the temperature cloud field of the whole machine is obtained. As shown in Figure 3.

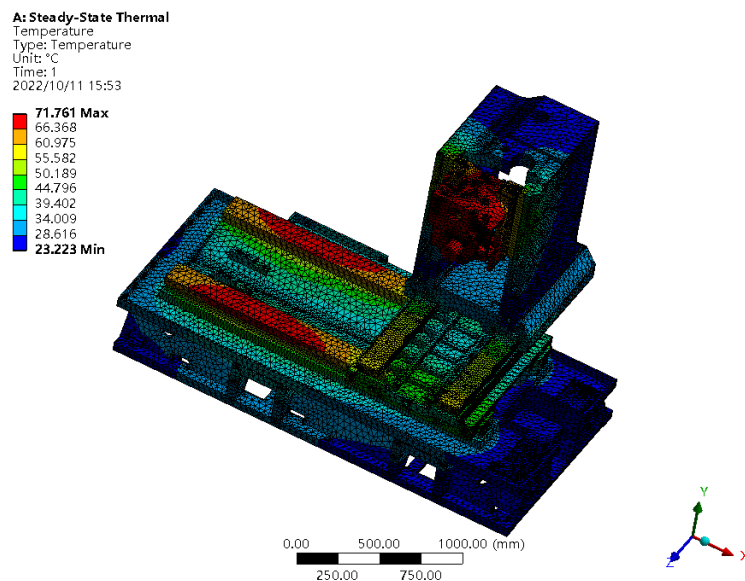

Fig. 3 Temperature field of horizontal machining center

It can be seen from the figure that the machine tool spindle box has the highest temperature, with the highest temperature of 71.761 degrees Celsius. This is because there is an electric spindle in the spindle box, which runs at a high speed, and the electric spindle heats itself, and the bearing supporting the electric spindle will also heat up seriously. Combined with various factors, the fever near the spindle box is serious. The uneven temperature of each part leads to the thermal deformation of the machine tool. In the following, detailed modeling, finite element analysis and neural network modeling will be carried out for the heating problem of the spindle system.

3.3 Deformation field analysis

After the steady-state temperature field of the machining center is obtained, this result is shared with the statics analysis module. Apply boundary conditions to the statics module, such as gravity, contact relationship, cutting force, etc. Then, mesh is divided and thermal-structural coupling analysis is carried out, and the deformation of the whole machine is obtained as shown in Figure 4.

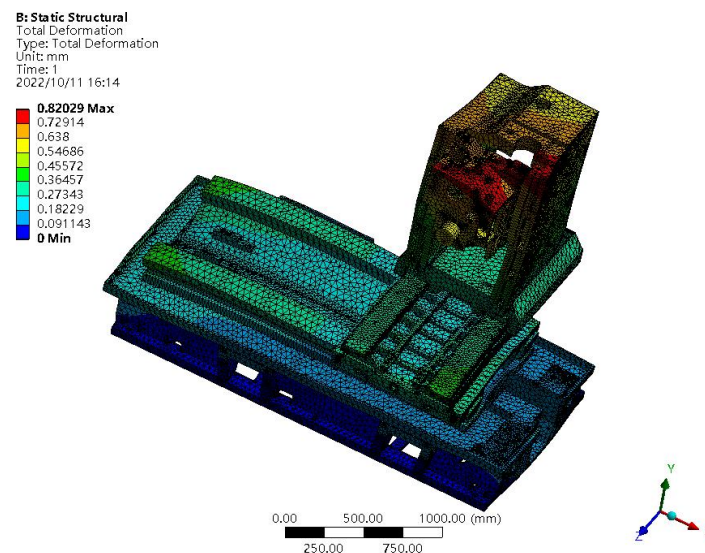

Fig. 4 cloud map of machine tool deformation

It can be seen from the figure that due to the influence of gravity, contact force and cutting force of parts, different parts of the machine tool have undergone different degrees of deformation, with the maximum thermal deformation occurring at the spindle, with a total deformation of 0.820mm. The thermal deformation of the bed and guide rail is small, and this stress-deformation cloud field can provide a theoretical reference for the later sensor layout.

4. Neural network based on time series optimizes the spindle thermal error analysis.

4.1 Finite Element Analysis of Machine Tool Spindle

For the establishment of the three-dimensional model of the spindle type of the machine tool, see Figure 5 for the sectional view of the three-dimensional model of the spindle of the machine tool. Then, the thermal-structural coupling analysis of the spindle is carried out. Firstly, the Transient Thermal module in WorkBench is opened for analysis, and the results of transient analysis are shared with the static analysis module. Get the temperature change of the first 6000s, and then extract the data of 36 temperature points, which are named as. Fig. 6 shows the temperature field of the machine tool at 20000s. It can be seen from the figure that the maximum temperature of the spindle of the machine tool is 39.492°C, and the highest point is in the middle of the spindle and the bearing. Generally, after the machine is turned on, it needs to be preheated. Different machine tools have different preheating time, and most machine tools preheat for about 30 minutes. $\Delta 1, \Delta 2, \Delta 3, \dots, \Delta 36$

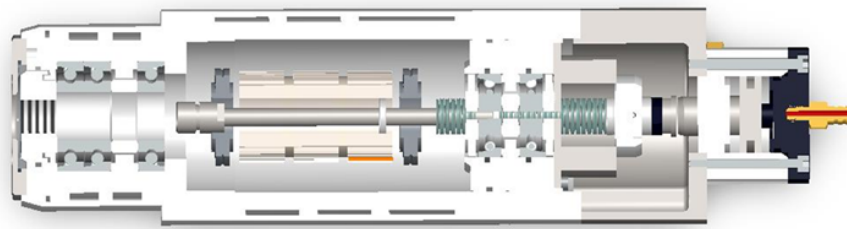

Figure 5 Three-dimensional model diagram of machine tool spindle

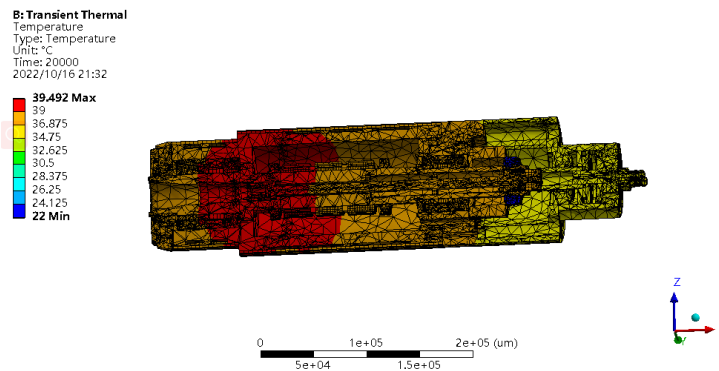

Fig. 6 Temperature field diagram of machine tool at 20000s

During the period from startup to 20000s, this is the temperature change chart of the outer ring of the spindle bearing of the machine tool with time, and the temperature rise data is named as As. As can be seen from Figure 7, the temperature of the machine tool rises rapidly at the beginning, and then the temperature of the machine tool gradually stabilizes at 10000s, which is in line with the actual situation. $\Delta 1$

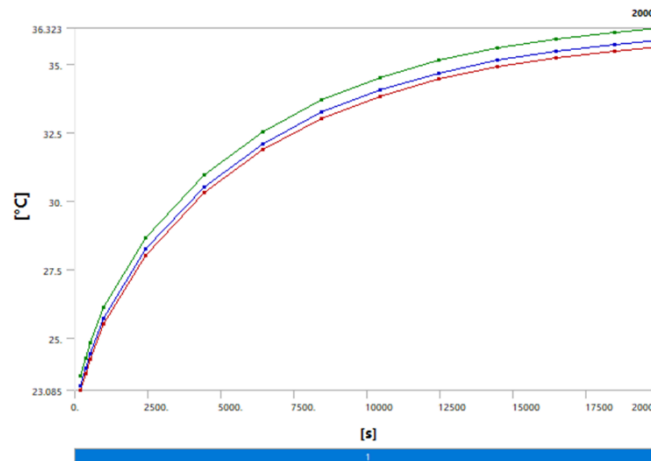

Fig. 7 Temperature-time curve of a certain point of bearing outer ring

4.2 Cluster analysis

According to the principle of selecting temperature measuring points, the data are analyzed by fuzzy clustering, and the fuzzy similarity matrix is established by using the correlation coefficient method. According to the fuzzy similarity matrix, the fuzzy equivalent matrix is obtained, and a certain threshold is selected for interception. Fig. 8 shows the relevant program for calculating fuzzy matrix, which is divided into four categories. Combining with the thermal deformation data, the complex correlation coefficient between nodes and thermal deformation is obtained,

and six better temperature sensitive points are selected.

```

1  c1c;
2  X=xlsread('wensheng');
3  R=[];
4  [m,n]=size(X);
5  for i=1:n
6      for j=1:n
7          A=X(:,i)-sum(X(:,i))/m;
8          B=X(:,j)-sum(X(:,j))/m;
9          C=sum(A.*B);
10         D=sqrt(sum(A.*A))*sqrt(sum(B.*B));
11         R(i,j)=C/D;
12     end
13 end
14 save dataR.txt R -ascii;
15 [m,n]=size(R);
16 P=[];
17 Q=[];
18 P=R;
19 while 0<1
20     for i=1:m
21         for j=1:n
22             Q(i,j)=max(min(P(i,:), transpose(P(:,j))));
23         end
24     end
25     if P==Q
26         Y=Q;
27     return;

```

Fig. 8 partial program chart of fuzzy cluster analysis

4.3 Thermal error modeling of neural network based on time series

BP neural network is a multi-layer feedforward neural network trained according to the error back propagation algorithm, which can correct the weight coefficients between neurons in different layers according to the prediction error until the error meets the requirements. It has been successfully applied to system modeling, digital recognition, speech classification and many other aspects. BP neural network has a good nonlinear fitting function. As a new spatial mapping method, it can establish a high degree of nonlinear mapping from space (n is the number of input neurons) to space (m is the number of output neural meridian elements) only by using sample data without building a complex system mathematical model. Mathematically, it has been proved that the three-layer neural network model can theoretically approximate any function. The neural network is a multi-layer perceptron structure, which can be divided into input layer, output layer and hidden layer, as shown in Figure 9.

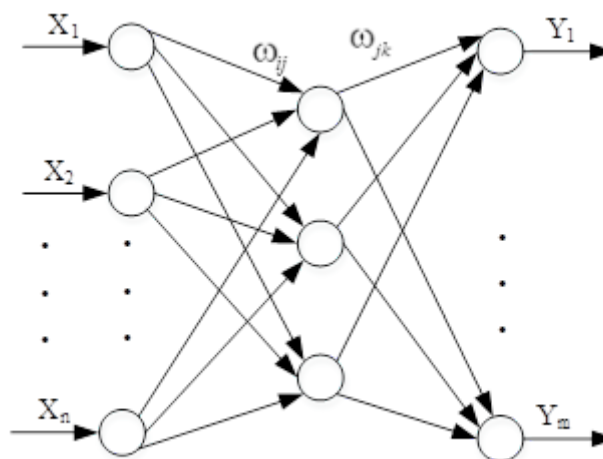

Fig. 9 Structure diagram of neural network

Then, the neural network based on time series and multiple linear regression analysis are used to model and analyze the data. A multiple linear regression can have one dependent variable and several independent variables. The spindle error of the machine tool is divided into axial error and radial error, so two multiple linear regression analyses are needed to compare the two algorithms and select the one with the best results.

Firstly, the data is normalized, and the method used here is the maximum-minimum method. $\Delta 1, \Delta 2, \Delta 3, \dots, \Delta 36$

Then the neural network of MATLAB time series is used for analysis. Figure 10 shows the error performance, from which it can be seen that the average variance gradually converges and the fitting effect is good. Figure 11 shows the regression curve. It can be seen from the figure that the regression effect is very good and the thermal error model of the machine tool is accurate.

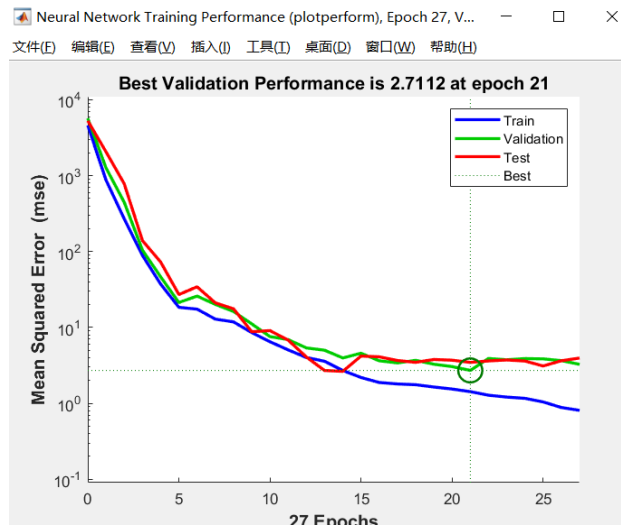

Fig. 10 error representation diagram

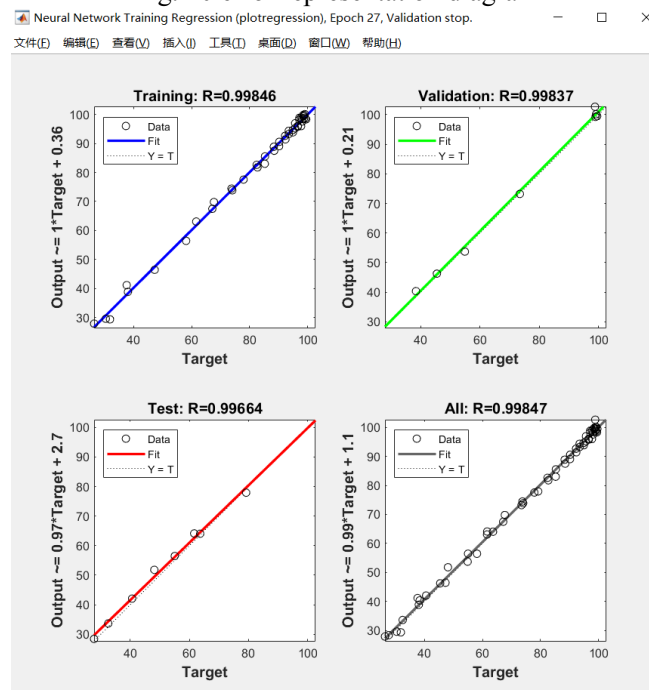

Fig. 11 Regression curve

4 Conclusion

In this paper, the horizontal machining center is taken as the object, and the thermal boundary conditions of the machining center under simulated conditions are calculated by establishing the thermal characteristic model of the machining center. Then, through finite element analysis, the temperature field distribution of the machine tool and the deformation law of the whole machine under the action of heat are obtained. It provides a theoretical reference for error compensation and machine tool optimization. For the serious problem of spindle heating, a detailed analysis of

the temperature source is carried out, and then 36 groups of temperature data are extracted. Then, the neural network based on time series is used to model and analyze the thermal error. Before machining, the machine tool is preheated to make the machine tool reach the thermal steady state.

references

- [1] Lu Yuandong, Xu Zhongxing, Liu Lixin, Equestrian Wen, Yan Shouhong. Thermal deformation error compensation technology of CNC machine tools [J]. *Machine Tools and Hydraulics*, 2007(02):43-45+50.
- [2] Meng Boyang, Li Maoyue, Liu Xianli, WANG Lihui, LIANG S Y, Wang Zhixue. Research progress on architecture and key technologies of machine tool intelligent control system [J]. *Journal of Mechanical Engineering*, 2021,57(09):147-166.
- [3] Jorgensen B R. Robust modeling of high-speed spindle-bearing dynamics under operating conditions[D]. West Lafayette: Purdue University, 1996.
- [4] Mian N S, Fletcher S, Longstaff A P, et al. Efficient thermal error prediction in a machine tool using finite element analysis[J]. *Measurement Science & Technology*, 2011, 22(8): 085107.
- [5] Yang Hong, Ni Jun. Dynamic neural network modeling for nonlinear, nonstationary machine tool thermally induced error[J]. *International Journal of Machine Tools & Manufacture*, 45(4-5): 455-465.
- [6] Huang Lin. Analysis and optimization of thermal characteristics of double spindle horizontal machining center [D]. Shanghai Jiaotong University, 2020.
- [7] Yin Ling. Research on robust compensation technology of machine tool thermal error[D]. Huazhong University of Science and Technology, 2011.
- [8] Zhaolong Li, Qinghai Wang, Bo Zhu, Baodong Wang, Wenming Zhu, Ye Dai, Thermal error modeling of high-speed electric spindle based on Aquila Optimizer optimized least squares support vector machine, *Case Studies in Thermal Engineering*, Volume, 39, 2022, 102432, ISSN 2214-157X,
- [9] Ji Peng, Ming Yin, Li Cao, Qihao Liao, Ling Wang, Guofu Yin, Study on the spindle axial thermal error of a five-axis machining center considering the thermal bending effect, *Precision Engineering*, Volume 75, 2022, Pages 210-226, ISSN 0141-6359,