

Design and Manufacture of Radiosonde Based on Arduino Pro Mini Using BME280 Sensor

ABSTRACT

Aims: To produce low-cost Radiosonde instruments with high accuracy, which are expected to be used as a reference in developing upper aerial observation instruments so as to reduce observation costs

Study design: Design of Radiosonde Based on Arduino Pro Mini Using BME280 Sensor.

Place and Duration of Study: Department of Physics, Udayana University, and Indonesian Agency of Meteorology, Climatology, and Geophysics (BMKG), Region-III Badung, between June 2022 and August 2022.

Methodology: Calibration is done by comparing the output value of the BME280 sensor and the BMKG calibration standard tool. The calibrated parameters are temperature, humidity, and air pressure. The relationship between the measurement value of the design tool and the standard tool is determined by the linear regression method to obtain the correction equation.

Results: Radiosonde instruments based on Arduino Pro Mini using the BME280 sensor have been produced. The measurement accuracy obtained for the temperature parameter is 99.9968% with uncertainty (U_{95}) of ± 0.18 °C, the humidity parameter is 99.296% with uncertainty (U_{95}) of $\pm 2.9\%$ RH, the air pressure parameter is 99.99998% with uncertainty (U_{95}) of ± 0.15 hPa. The accuracy value indicates that the resulting tool has a good level of accuracy to the standard tool.

Conclusion: In this research, has been produced a Radiosonde instruments at a low-cost with high accuracy and precision, which have been calibrated with BMKG standard tools.

Keywords: Radiosonde; transmitter; Arduino Pro Mini; BME280 sensor, telemetry.

1. INTRODUCTION

Observation of upper air profiles is an activity undertaken by Indonesian Agency of Meteorology, Climatology, and Geophysics (BMKG) to obtain weather parameter data on certain atmospheric layers. These data are useful for the numerical analysis of weather predictions that are very useful for the needs of operational forecasts [1]. Currently, upper air observations in BMKG are conducted using Pilots Balloon and Radiosonde [2]. Observations with Radiosonde provide more complete weather parameter observation data than the Pilots Balloon do, but observation of upper air profile using Radiosonde has not been done evenly in all meteorological stations. Observations using Radiosonde are still limited due to the high cost of observations. Based on these conditions, researchers are interested in conducting research to produce low-cost Radiosonde instruments with high accuracy, which are expected to be used as a reference in developing upper aerial observation instruments so as to reduce the cost of observations.

1.1 Radiosonde

Many researchers used Radiosonde data to evaluating their forecasting models. A Radiosonde invented in 1920 to measure the basic meteorological variables in the troposphere and stratosphere [3], [4]. Radiosonde comes from the words radio and sonde. Radio is an electromagnetic wave that propagates at frequencies of 100 kHz to 100 GHz, while sonde comes from French which means investigator, or in this case sensor [5]. Radiosonde (Rason) is an electronic device used to observe weather parameters in the upper air layer. Radiosonde data are the upper air data from the atmosphere, starting at three meters above the earth's ground surface. These upper air data received from Radiosonde are transmitted back to the receiver unit on the ground [6]. The data obtained by Radiosonde observations are air temperature, air humidity, air pressure in the earth's surface layer to the upper layer, wind direction and speed, as well as geographical position and transmitter height. By analyzing data on pressure, altitude, temperature, air humidity as well as

wind direction and speed, symptoms of changes in the nature of air masses can be detected. To detect the chances of rain, observational data is plotted into aerological diagrams either manually or automatically with Rawinsonde Observation (RAOB) software. Radiosonde consists of a transmitter and a receiver. The Radiosonde transmitter is equipped with a top-layer weather observation sensor flown with the help of a hot air balloon filled with hydrogen gas. The receiver system consists of an indoor receiver and an outdoor receiver that functions to receive data. The Radiosonde used by BMKG is currently the Meisei IMS-100 [7].

1.2 Arduino Pro Mini

Arduino Pro Mini is a microcontroller board based on the ATmega328P. The Arduino Pro Mini has 14 digital input/output pins, 6 analog input pins, a reset button and a hole for pin header mounting. Pin headers can be connected to FTDI cables or breakout boards for power supply and communication via Universal Serial Bus (USB). Arduino Pro Mini is intended for semi-permanent installation. On the Arduino Pro Mini board, the pin header is not paired directly, only the female sphere without a header allows the use of various types of connectors or with direct soldering [8].

1.3 BME280 Sensor

Bosch Sensortec's BME280 sensor is an integrated sensor with temperature, humidity, and air pressure sensors based on proven **sensing** principles. The BME280 is compatible with Bosch Sensortec's BMP180 digital pressure sensor [9]. The BME280 provides Serial Peripheral Interface (SPI) and Inter-Integrated Circuit (I2C) interfaces and can be supplied with an input voltage of 1.71 V to 3.6 V for sensor voltage supply (VDD) and 1.2 V to 3.6 V for interface supply (VDDIO). Sensor measurements can be triggered by the host or displayed periodically. When the sensor is disabled, the current consumption will drop to 0.1 μ A. In the I2C interface feature, there are Serial Clock (SCL), Serial Data (SDA), input voltage (VIN) and ground (GDN) pins [10].

2. MATERIAL AND METHODS

2.1 Design of System

The design used is shown in Figure 1. This design consists of a transmitter and receiver that will be assembled separately with different microcontrollers. The transmitter's design uses an Arduino Pro Mini microcontroller as a control center to handle routine data communication, while the receiver uses the Esp32. The **transmitter is designed** to do observations by utilizing the BME280 sensor to provide measurements of temperature, humidity, air pressure as well as a GPS module to provide longitude, latitude and altitude position data. The observation data is transmitted to the receiver through radio waves emitted by the LoRa module. Then, the data sent by the transmitter will be received by the LoRa module on the receiver. Observational data will be parsed and converted to be displayed on OLED.

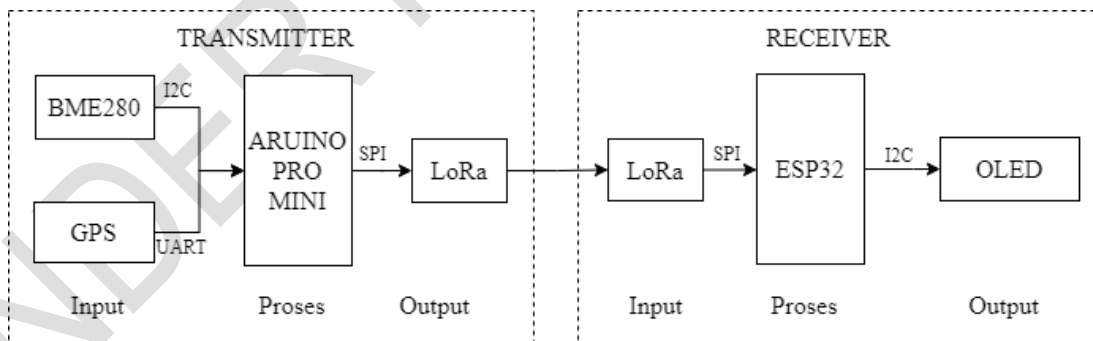

Figure 1. Block diagram of design tool.

2.2 Calibration Methods

Calibration is the application of observation equipment by comparing the designation of a measuring instrument with known and traceable standard values [11]. Data collecting for calibration is carried out by observing the output data of the BME280 sensor and BMKG standard tools. Calibration correction is performed by determining the relationship of the measurement value of the design tool with the standard tool using linear regression. This linear model is then applied to the program code on the design tool measurement model, so that the measurement results of the design tool will show good conformity with the standard tool [12]. The calibrated parameters are temperature, humidity, and air pressure.

3. RESULTS AND DISCUSSION

3.1 Result

Research on designing Radiosonde based on Arduino Pro Mini using BME280 sensor, carried out in the Electronics and Instrumentation Laboratory of Physics Department, Udayana University and Calibration Laboratory of the Meteorological, Climatological, and Geophysical, Region-III Badung, from June 2022 to August 2022. The design of Radiosonde based Arduino Pro Mini using BME280 sensor is shown in Figure 2 and the schematic design is shown in Figure 3

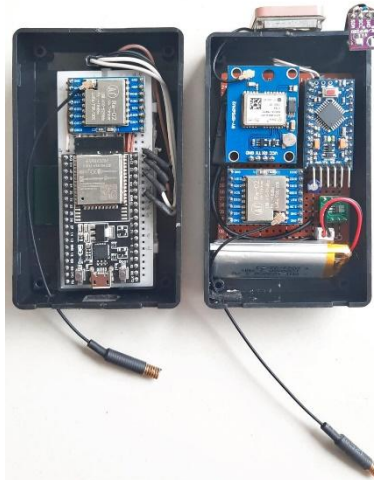

Figure 2. Result of design tool.

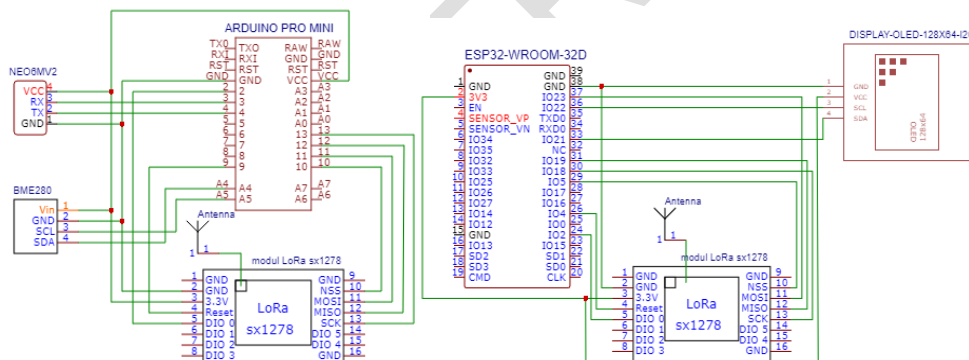

Figure 3. Schematic design

3.2 Discussion

3.2.1 Calibration of Temperature Parameter

Temperature calibration is carried out to test the temperature measurement value of the design tool with a Fluke Hart Scientific digital thermometer on the Temperature Test Chamber calibration media. Calibration is performed in the set point range of 0-50 °C in increments of 10 °C at each set point. The data on the calibration results of temperature parameters are shown in Table 1

Table 1. Calibration Data of Temperature Parameter

Set Point (°C)	Reference Tool (°C)	Design Tool (°C)	Correction (°C)	U ₉₅ (°C)	Deviation Standard
0	-0.06	0.85	-0.91	0.18	0.013
10	10.01	10.73	-0.72	0.18	0.006
20	20.04	20.67	-0.63	0.18	0.003
30	30.03	30.66	-0.63	0.18	0.000

40	40.08	40.42	-0.34	0.18	0.012
50	50.09	50.65	-0.56	0.18	0.024

*U95 = measurement uncertainty at a 95% confidence level

The data in Table 1 shows the uncertainty value (U_{95}) of the temperature measurement obtained at ± 0.18 °C. The value still meets the tolerance of the uncertainty value of the temperature measurement set by WMO, which is a maximum of ± 0.2 °C [11]. The standard deviation obtained shows a fairly small value, which indicates that the sensor has a good level of precision for the air temperature parameter. The calibration data in Table 1 is plotted into a linear test graph as shown in Figure 4.

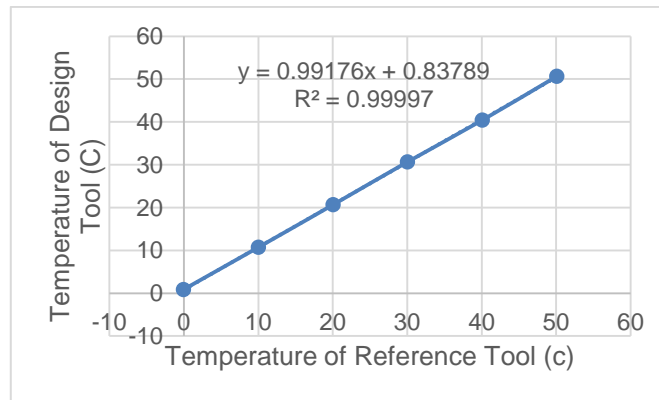

Figure 4. Graph of temperature parameter calibration.

Based on the plotted data, a linear equation was obtained with a regression coefficient (gradient) of 0.99176 and a constant of 0.83789 which indicates that there is still a potential deviation of the measurement results by the design tool against the measurement results of the standard tool. For this reason, it is necessary to make corrections to adjust the measurement results of the design tool to the standard tool. The results of temperature measurements that have been adjusted to the standard are shown in the graph in Figure 5

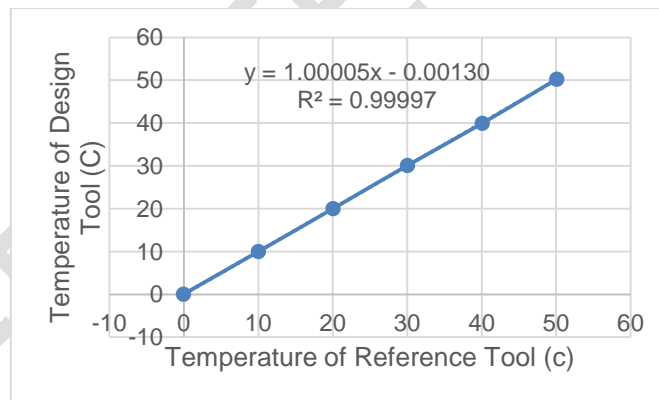

Figure 5. Graph of temperature parameter adjusted to standard.

The regression results in Figure 5 shows a linear equation, where in the equation a gradient of 1.00005 is obtained which is getting closer to one and a regression constant of -0.00130 which is getting closer to zero, so that an equation close to $y = x$ can be obtained. This shows that after correction, measurement results will be obtained between the design tool and the standard tool which is very close to the same. In addition, the value of the coefficient of determination (R^2) of 0.99997 was obtained. This value can be interpreted to mean that the level of accuracy of the measurement results of the design tool against the standard tool is 99.997%.

3.2.1 Calibration of Relative Humidity Parameter

Relative humidity calibration was carried out to test the air humidity measurement value of the design tool with the Vaisala Digital Thermohygrometer on the Peltier Climatic Chamber calibration media. Calibration is carried out at set points of 40, 60, 80 %RH. The data on the calibration results of humidity parameters are shown in Table 2

Table 2. Calibration Data of Humidity Parameter

Set Point (%RH)	Reference Tool (%RH)	Design Tool (%RH)	Correction (%RH)	U_{95} (%RH)	Deviation Standard
40	38.80	43.80	-5.00	2.9	0,03
60	58.48	61.19	-2.71	2.9	0,01
80	79.11	85.69	-6.58	2.9	0,03

* U_{95} = measurement uncertainty at a 95% confidence level

The data in Table 2 shows the uncertainty value (U_{95}) of air humidity measurements obtained at ± 2.9 %RH. This value still meets the tolerance of the uncertainty value of air humidity measurement set by WMO, which is a maximum of ± 3 %RH [11]. The standard deviation obtained shows a fairly small value, it indicates that the sensor has a good level of precision for air humidity parameters. The calibration data in Table 2 is plotted into a linear test graph as shown in Figure 6.

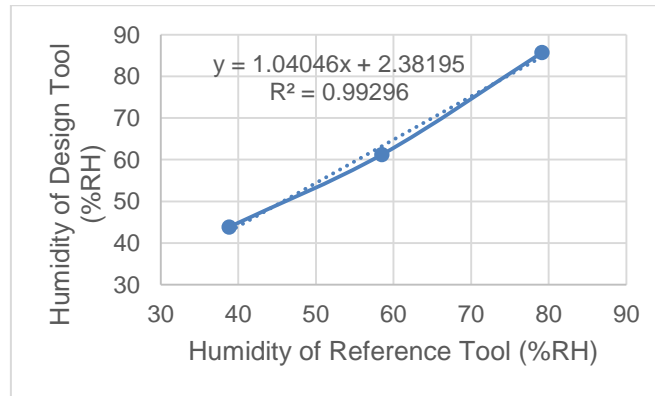

Figure 6. Graph of humidity parameter calibration.

Based on the plotted data, a regression coefficient (gradient) of 1.04046 and a constant of 2.38195 were obtained which indicated that there was still a potential deviation of the measurement results by the design tool against the measurement results of the standard tool. For this reason, it is necessary to make corrections to adjust the measurement results of the design tool to the standard tool. The results of humidity measurements that have been adjusted to the standard are shown in the graph in Figure 7

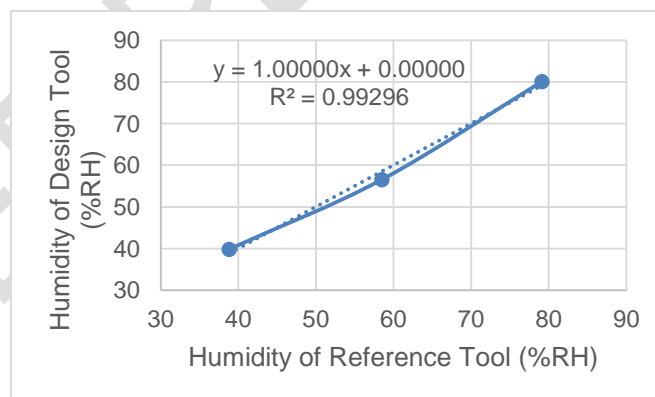

Figure 7. Graph of humidity parameter adjusted to standard.

The regression results in Figure 7 shows a linear equation, where in the equation a gradient is 1.0000 and the regression constant is 0. This shows that after correction, measurement results will be obtained between the design tool and the standard tool which is very close to the same. In addition, the value of the coefficient of determination (R^2) of 0.99296 was obtained. This value can be interpreted to mean that the level of accuracy of the measurement results of the design tool against the standard tool is 99.296%.

3.2.1 Calibration of Air Pressure Parameter

Pressure calibration is carried out to test the air pressure measurement value of the design tool with the Vaisala Digital Barometer on the Pressure Chamber Theodore calibration media. Calibration is carried out at set points of 800 – 1050

hPa in increments of 50 hPa per set point. The data on the calibration results of air pressure parameters are shown in Table 3

Table 3. Calibration Data of Air Pressure Parameter

Set Point (hPa)	Reference Tool (hPa)	Design Tool (hPa)	Correction (hPa)	U_{95} (hPa)	Deviation Standard
800	800.10	800.26	-0.16	0.07	0,02
850	850.14	850.37	-0.23	0.07	0,01
900	900.20	900.48	-0.28	0.08	0,05
950	950.33	950.62	-0.29	0.09	0,07
1000	1000.22	1000.48	-0.26	0.10	0,10
1050	1050.07	1050.30	-0.24	0.08	0,07

* U_{95} = measurement uncertainty at a 95% confidence level

The data in Table 3 shows the uncertainty value (U_{95}) of the obtained pressure measurement of ± 0.10 hPa. This value still meets the tolerance of the uncertainty value of pressure measurement set by WMO, which is a maximum of ± 0.15 hPa [11]. The standard deviation obtained shows a fairly small value, it indicates that the sensor has a good level of precision for the air pressure parameter. The calibration data in Table 3 is plotted into a linear test graph as shown in Figure 8.

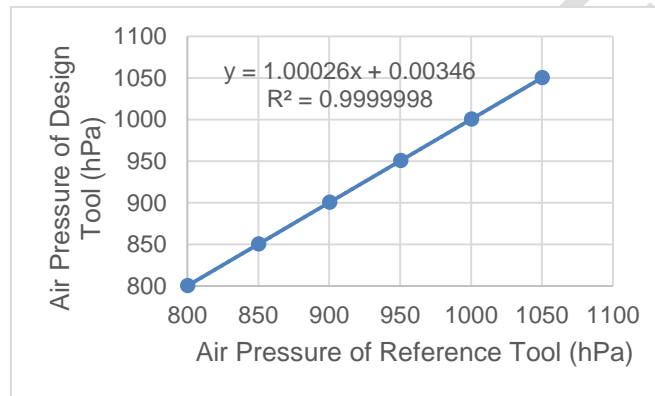

Figure 8. Graf of air pressure parameter calibration.

Based on the plotted data, a regression coefficient (gradient) of 1.00026 and a constant of -0.00346 were obtained which indicates that there is still a potential deviation of the measurement results by the design tool to the measurement results of the standard tool. For this reason, it is necessary to make corrections to adjust the measurement results of the design tool to the standard tool. The results of air pressure measurements that have been adjusted to the standard are shown in the graph in Figure 9

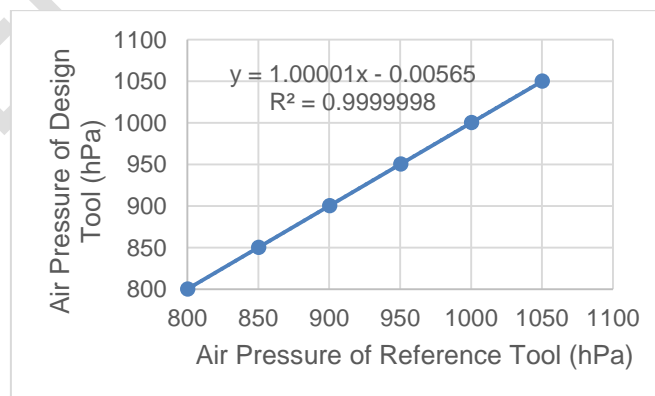

Figure 9. Graph of air pressure parameter adjusted to standard.

The regression results in Figure 9 shows linear equations, where in the equations a gradient of 1.00001 is obtained which is getting closer to one and a regression constant of 0.00565 which is getting closer to zero, so that an equation close to $y = x$ can be obtained. This shows that after correction, measurement results will be obtained between the design tool and the standard tool which is very close to the same. In addition, the value of the coefficient of determination (R^2) of

0.9999998 was obtained. This value can be interpreted to mean that the level of accuracy of the measurement results of the design tool against the standard tool is 99.99998%.

4. CONCLUSION

The conclusions obtained are:

1. Radiosonde instruments based on Arduino Pro Mini using the BME280 Sensor have been produced, which consists of a transmitter system and receiver.
2. The resulting instruments have been calibrated with BMKG standard tools. Calibration is carried out by comparing the measurement results of the design tool with the BMKG tool so that tool accuracy is obtained through the calculation of the coefficient of determination. The resulting tool has a good level of accuracy and precision for the measurement of temperature, humidity and air pressure parameters.

COMPETING INTERESTS

Authors have declared that no competing interests exist.

AUTHORS' CONTRIBUTIONS

This work was carried out in collaborating among all authors. All authors read and approved the final manuscript.

REFERENCES

1. Jaelani Hidayat, D., Tri Susanto, A., Maulana Rafi, A., & Krisna Lingga Aditama, G. Design a Radiosonde system for observation of upper air profiles. Proceedings of the Earth and Atmosphere Seminar. 2018; 568-575. South Tangerang: STMKG.
2. BMKG Class I Ngurah Rai. Operation of Radiosonde at Ngurah Rai Class I Meteorological Station Denpasar. In: A. S. Syahdian & L. Novita A. W., eds. Meteorological Equipment Park. Denpasar: Meteodrome, 2018; 19 - 21.
3. T. M. Griffin, S. R. Colwell, C. J. Wright, N. P. Hindley, and N. J. Mitchell, Radiosonde Observation of a Wintertime Meridional Convergence of Gravity Waves Around 60°S in the Lower Stratosphere, Geophysical Research Letters, vol. 47, 2020, doi: 10.1029/2020GL089740.
4. A. Martin, M. Weissmann, O. Reitebuch, M. Rennie, A. Geib, and A. Cress. Validation of Aeolus Winds Using Radiosonde Observations and Numerical Weather Prediction Model Equivalents. Atmospheric Measurement Techniques, vol. 14, pp. 2167-2183; 2021
5. BMKG Class I Ngurah Rai. Radiosonde (Rason). In: A. Fadianika and P. Rka. T., , eds. Upper Air Observations. Denpasar: Meteodrome; 2018; 16 - 20.
6. Joseph, J. J. et al. Weather Observation and Forecasting Using Radiosonde. Telkomnika (Telecommunication Computing Electronics and Control), vol. 20 (6), 2022, doi: 10.12928/TELKOMNIKA.v20i6.24247.
7. BMKG Class I Ngurah Rai. How to Observe the Weather in the Upper Air. In: B. Personal & L. Ariastuti, eds. Observing Upper Air Weather. Denpasar: Meteodrome; 2017; 16 - 19.
8. Arduino CC, 2021. *Arduino Pro Mini*. Accessed 5 Februari 2022. Available at: <https://www.arduino.cc/en/pmwiki.php?n=Main/ArduinoBoardProMini>
9. Utama, Y. A. K., Widiyanto, Y., Sardjono, T. A. & Kusuma, H. Quality comparison between air humidity sensors using Arduino Uno. Semarang, Proceedings of the National Seminar on Science and Technology, Faculty of Engineering, Wahid Hasyim University; 2019.
10. Bosch Sensortec GmbH, 2018. *BME280*. Accessed 8 Februari 2022. Available at: <https://www.bosch-sensortec.com/media/boschsensortec/downloads/datasheets/bst-bme280-ds002.pdf>

11. *World Meteorological Organization (WMO), Guide to Meteorological Instruments and Methods of Observation*, Geneva: *Publication WMO*; 2018.
12. Laksono, A. and Widagda, I.G.A., Calibration of the BMP280 and ESP-12 Based Wireless Atmospheric Pressure Measure Equipment Using a Pressure Chamber. *Buletin Fisika*, vol. 23 (1), 2021; 1-11, doi: 10.2483/BF.2022.v23.i01.p01.

UNDER PEER REVIEW