

Review on reinforcement-concrete bonded anchorage

ABSTRACT

In order to obtain the study of the bonding properties between the reinforcement-concrete and give full play to the material properties, a lot of research has been carried out on reinforcement-concrete. Existing reinforcement-concrete studies contain mainly reinforcement-concrete bonds, reinforcement lap, and anchorage of reinforcement. The reinforcement-concrete bond test mainly measures the bond-slip curve between the two to determine the bond strength between reinforcement and concrete. The reinforcement lap test is mainly used for the performance study of the anchorage length of reinforcement in concrete, whether the lap bars are in contact with each other, which can be divided into two forms: contact lap and indirect lap. The anchorage test of reinforcement is conducted to study the reduction of the connection length between reinforcement and concrete while meeting the force requirements. According to a large number of tests, the bond strength of the reinforcement is affected by the shape of the mixed reinforcement, the thickness of the protective layer of the diameter concrete, the spacing of the reinforcement, the transverse reinforcement restraint, and the material properties of the reinforcement and concrete. This paper discusses the test methods, influencing factors, and the lack of existing research in the study of the performance of reinforcement-concrete bonding, and lap and anchorage properties.

Keywords: reinforcement-concrete, bond, lap, anchorage, center pull out, bond-slip principal structure mode

1. Introduction

Reinforced concrete is a composite material made by combining two materials with different physical and mechanical properties, steel and concrete [1], and its intrinsic model is complex [2-22]. The bond-slip performance of steel and concrete has been a hot topic of research [23-35], but there are due to its many influencing factors, different test methods, etc. resulting in different variability of test results. This paper presents the existing domestic research on reinforcement-concrete bonding and anchorage etc. in recent years to provide a reference for the subsequent research. The rebar materials used in this paper are all hot-rolled ribbed rebar with ultimate tensile strength up to 400MPa without special explanation.

2. Steel-concrete bonding study

There are three existing test methods to study the bond between reinforcement-concrete, which are pull-out test (Figure 1), beam test (Figure 2) and axial tensile test. The pull-out test is mainly used to measure the bond stress and relative slip of the reinforcement-concrete, when the bond strength of the reinforcement-concrete is high, the specimen is more splitting damage, and therefore does not fully reflect the bond performance between the reinforcement and concrete, but because the specimen is easy to make and test the characteristics of the test method is widely used. Beam test specimens are not only subjected to tension, but also to shear and bending moment, so the beam test method is more suitable for the bond anchorage test at the end of the beam. The shortcomings of the beam test are the large size of the specimen, the high production cost and the complexity of the test. The axial tensile test can measure the inter-seam bond force and relative slip, and is generally used to simulate the bond characteristics between cracks in purely curved sections of beams, in contrast to axial tensile specimens which are not suitable for the study of bond slip curves between reinforcement-concrete.

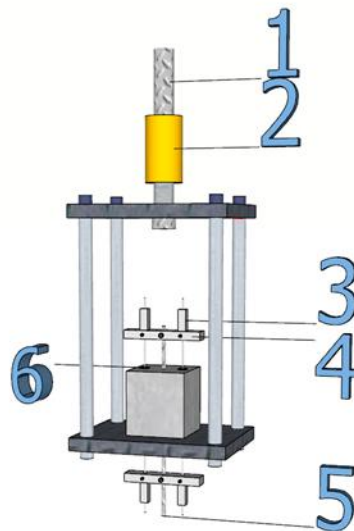

1 - upper chuck 2 - force transducer 3 - displacement meter
4 - displacement meter bracket 5 - lower chuck 6 - glass sheet

Figure 1. Bond test pull-out test loading schematic [36]

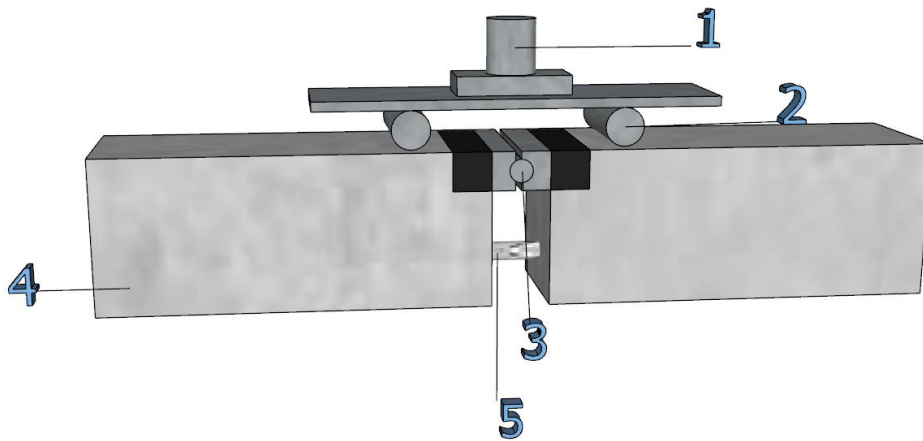

1- Upper loading device 2-Loading distribution point 3-Turning hinge
4-Test block 5-Rebar

Figure 2. Schematic diagram of the beam test loading device[36]

The bond strength of the deformed reinforcement is mainly expressed as the mechanical bite between the convex rib on the surface of the reinforcement and the concrete, but at the beginning of the loading mainly by the chemical bonding force and the friction force together, so the slip at the loading end is small when the pulling force is small, and the free end basically has no slip; with the increase of the pulling force, the chemical bonding force is gradually destroyed, and the free end starts to slip; when the pulling force continues to increase, the slip is gradually accelerated, and finally, due to the bite between the convex rib on the surface of the reinforcement and the bite force of the concrete produces a large transverse tensile stress, which causes the specimen to split. For the specimens without transverse hoops, the relative protection layer is thin and the splitting damage occurs; with the increase of the relative protection layer thickness, the damage form of the specimen changes to the anchor pulling damage; for the specimens with transverse hoops, the splitting damage does not occur because of the restraint of the hoops, and finally the concrete is crushed and the reinforcement is slowly pulled and damaged.

Yong Zhang [37] et al. analyzed the characteristics of reinforcement bond anchorage and the main factors affecting the bond anchorage strength through pull-out tests of 36 reinforcement and concrete bond anchorage specimens. The bond strength was found to increase with the strength of concrete due to the higher compressive strength of higher strength concrete under the action of reinforcement ribs. The influence of diameter on the bond strength was not significant when the diameter of the reinforcement was less than 16 mm, and the bond strength decreased significantly when the diameter was greater than 20 mm. The bond stress in the straight anchor section of the specimen with relatively long anchorage length is not uniformly distributed along the reinforcement, and the average bond stress is lower, while the bond stress in the straight anchor section of the specimen with small anchorage length is uniform and

plentiful, and the average bond stress is higher, so the bond strength of the specimen decreases as the anchorage length increases.

Weiping Zhao [38] et al. explained the reinforcement-concrete bond-slip intrinsic model through analysis (As in Figure 3, the test is a bond pull-out test, the red curve is the bond slip curve at the free end of the reinforcement, and the black curve is the bond slip curve at the loaded end of the reinforcement), explaining that the reason for the existence of the falling section of the curve is that when the concrete occlusal teeth between the ribs are sheared off, the transmission mechanism of the tapered wedge action no longer exists. As the reinforcement with inter-rib filled concrete is slowly pulled out, the bond stress decreases rapidly. The main reasons for this are twofold: first, the sheared concave-convex interface is gradually frustrated cementite particles grinding fine, grinding fine particles in the interface rolling thus leading to a negative exponential decay of the friction coefficient, the frictional resistance is reduced, the second, with the increase in the amount of slip concrete powder is constantly brought out, will lead to a reduction in the contact surface pressure.

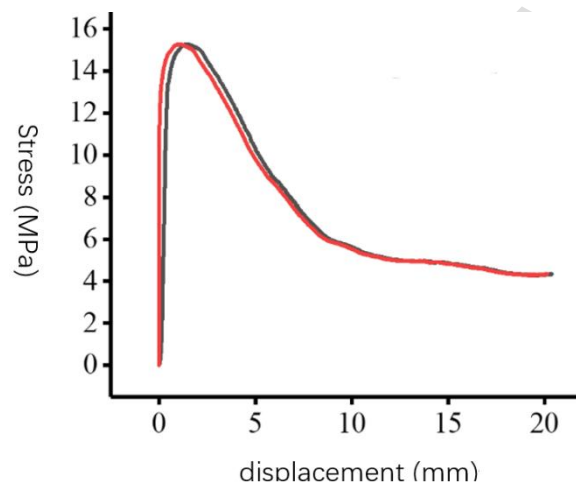

Figure 3. Bonding slip curve [38]

Minghua Zhao [39] et al, used 14mm diameter HRB400 (Hot-rolled ribbed steel bars with tensile strength up to 400MPa) grade reinforcement, concrete test 200mm*200mm*150mm by pull-out test to compare the results of an experimental study of bond strength of the natural aggregate and recycled aggregate concrete, the results show that the normalized bond strength is little affected by the factor that recycled aggregate replaces normal aggregate, meanwhile by calculating the design anchorage length provided by standards such as hair MC2010(The International Structural Concrete Association fib published a new version of the Model Code in 2012) and EC2(Eurocode for the design of concrete structures) can be applied to RAC (Recycled Coarse Aggregate Concrete).

An Xinzhen [40] et al. used HRB400E (hot-rolled ribbed steel bars with tensile strength up to 400 MPa to meet the seismic requirements) reinforcing bars in a center-drawing test to study the bonding performance of recycled concrete with 100% recycled coarse aggregate replacement, by varying the recycled fine aggregate replacement rate β (0%, 30%, 50%, 70%,

100%) and reinforcing bar diameter d (12 mm, 14 mm, 18 mm). 14mm, 18mm), 72 sets of 150mm*150mm*150mm center-drawn specimens were designed, in which the effective bond lengths were all 5D, with PVC (plastic pipe) sleeves at both ends and sealed. The bond-slip curves of the test results are shown in Fig. 4, Fig. 5, and Fig. 6, from which it can be found that the ultimate bond stress and initial bond stiffness of reinforced-regenerated concrete decrease with the increase of recycled fine aggregate replacement rate and reinforcement diameter.

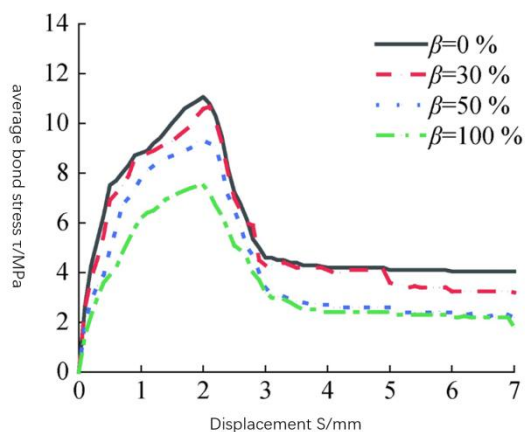

Figure 4. τ -s curve with different substitution rate β for 12mm diameter of steel bar [40]

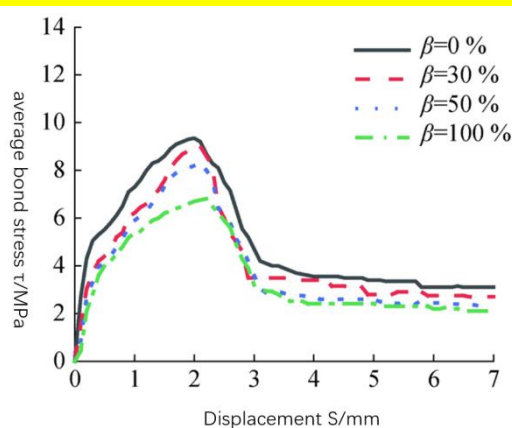

Figure 5. τ -s curve with different substitution rate β for 14mm diameter of steel bar [40]

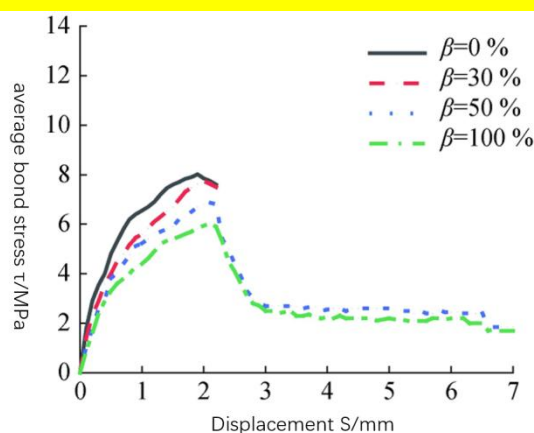

Figure 6. τ -s curve with different substitution rate β for 18mm diameter of steel bar [40]

3. Reinforced-concrete lap joint study

Reinforcing steel-concrete lap test is a special form of bond test, the lap performance between the reinforcing steel largely determines the anchorage length of the reinforcing steel. The lap joint of reinforcement in the steel-concrete bonding is tied lap joint and indirect lap joint, of which indirect lap joint is again one of the important forms of reinforcement connection in the assembly building. Tie lap is the reinforcement tied together with ties, and indirect lap is a certain distance between the reinforcement. There are usually 2 methods of lap joint test, which are two bars lap joint method (Figure 3) and four bars lap joint method (Figure 4), two bars lap joint method loading method is to pull 2 bars, and four bars lap joint method using 2 bars on one side connected together with connectors and then pull, four bars lap joint method and two lap joint method can eliminate the eccentric force generated by its pull test.[36]

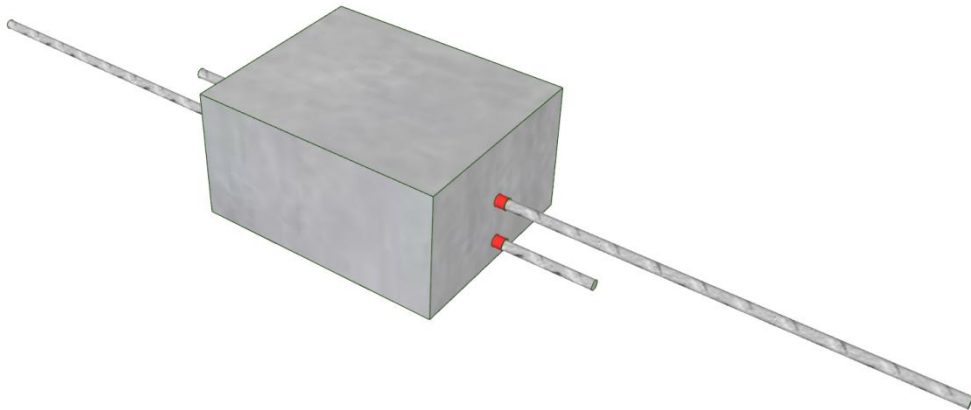

Figure 7: Double reinforcement lap test[36]

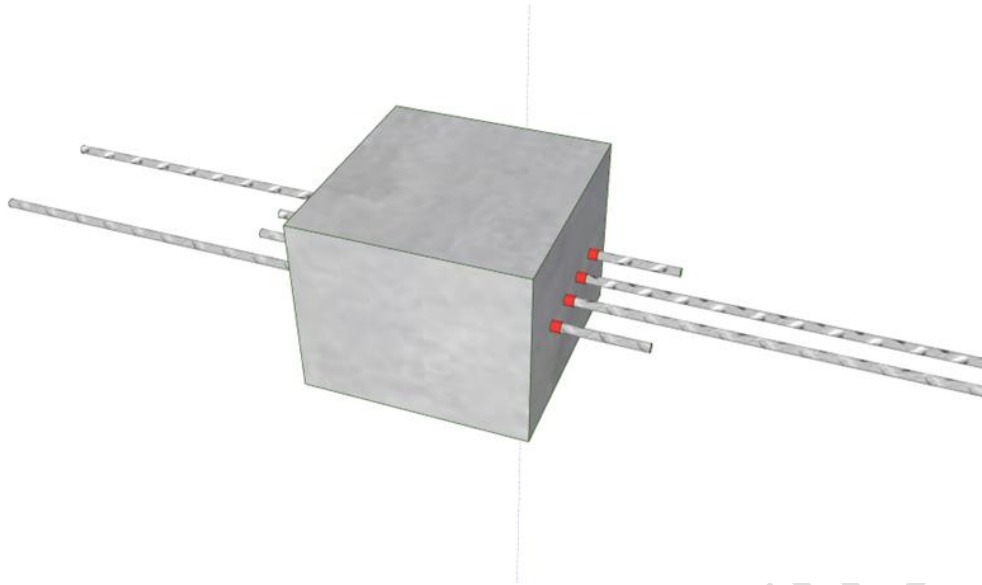

Figure 8: Four rebar lap test[41]

Yu'an Mei [42] et al. obtained by statistical analysis that the bond strength of lapped reinforcement and grout increased with the increase of split tensile strength of grout, protective layer thickness, and volumetric hoop ratio, and decreased with the increase of lap length of reinforcement, while the effect of net distance of reinforcement on bond strength was not obvious, and the effect of lap length of reinforcement and volumetric hoop ratio on bond strength was significant.

Shangjie Pan [41] et al. studied the principle and method of lap structure of lapped reinforcement out of horizontal splice lap of stacked slab shear wall, in order to study the force transfer efficiency of lap reinforcement at horizontal splice of stacked slab shear wall structure and its stress-strain situation, two groups of shear wall horizontal splice reinforcement lap specimens were designed and designed as 1 and 2 bars lap, the diameter of selected 1 steel lap reinforcement was Through the test, the stress-strain of lap bars at the horizontal splice of the laminated slab shear wall with different structural measures was studied and analyzed; the stress transfer efficiency of indirect lap bars and the damage pattern of the specimens. It was found that the single-row lap splice specimens and double-row lap splice specimens at the horizontal splice were damaged in tension at approximately the same location, and the damage pattern of the upper end of the single-row lap splice specimens was better without large cracks, while the upper end of the double-row lap splice specimens showed obvious cracks. The lower end of the specimens showed different degrees of diagonal tensile damage mainly because the protective layer thickness of the longitudinal tensile reinforcement in the prefabricated slab was insufficient. The test results are shown in Table 1, from which it can be found that the yield point and ultimate value of the single-row lap 16mm reinforcement specimen and double-row lap 12mm specimen are basically the same, and their displacement load curve trends basically match, this situation occurs because the test reinforcement lap length is too long, thus the reinforcement can reach the ultimate load value. The lap length of the reinforcement is too long so that its lap performance is excessive, and at the same time, the material is not fully utilized, and the specific condition of the reinforcement cannot be obviously known, thus the lap

performance of the reinforcement cannot be clearly reflected.

Table 1: Summary of test results [41]

Specimen number	Yield load (KN)	Ultimate load (KN)	Yield strength (MPa)	Ultimate load (MPa)	Forms of damage
The single row of reinforcement - 1	90.1	121.2	450.5	606	Rebar pulled off
The single row of reinforcement - 2	93	116.4	465	582	Splitting damage to the specimen
The single row of reinforcement - 3	87.9	120.5	439.5	602.5	Rebar pulled off
The double row of reinforcement - 1	92.8	115.6	410.6	511.1	Integral penetration damage to the specimen
The double row of reinforcement - 2	92.6	113.2	409.7	500.9	Shear damage to the specimen
The double row of reinforcement - 2	92.9	109.5	411.1	484.5	Shear damage to the specimen

Ying Lv [36] studied the indirect lap of reinforcement in the plate, considering one to one (i.e. one additional reinforcement and one prefabricated base plate reinforcement) pulling test exists eccentric force, thus the design is two to two (i.e. each group of specimens contains 2 groups of lap bars), through the test it was found that when the lap length is $0.8l_a$ (l_a represents the bonding length of the steel bar in concrete, and the bonding length is 35 times the diameter of the steel bar) of the lap length specified in GB50010 (China Concrete Structure Design Code), it can also meet the force requirements, and the diameter size changes in a small range No significant effect on the indirect lap strength.

In order to study the lap performance of indirect lap reinforcement in concrete and the influencing factors, Fan Yang [43] designed 24 beams, considering the loading method, reinforcement diameter, lap reinforcement spacing, and hoop restraint factors, so the loading methods were designed with four-point loading and three-point loading, the reinforcement diameters were selected as 18mm and 25mm, the lap reinforcement spacing was selected as 0, 2 times the reinforcement diameter, and 4 times the lap reinforcement. According to the test results, the indirect lap has influence compared with the contact lap, and the size of the influence depends on whether there are hoops or not, when there are hoops, the ultimate stress of the reinforcement increases with the increase of the lap spacing, when the indirect lap spacing is 4D, the ultimate stress is increased by 33%. When there is no hoop, the effect is not significant. The restraint effect of the hoop can significantly improve the bond strength of the reinforcement, and the three-point loading method has a significant increase of about 30% in the stress of the reinforcement compared with the four-point loading method.

4. Anchorage study of steel-concrete

The factors affecting the anchorage of reinforcement are divided into the following: First, there is a chemisorption force on the building surface, that is, there is a bonding force between the concrete and the surface of the reinforcement. Second, the structure of the building project is in a state of stress, the concrete and the surface of the reinforcement will form a friction force, and this force is correlated with the contact roughness of the concrete as well as the reinforcement. Third, the mechanical bite force. The surface of concrete and reinforcement is uneven, thus creating an occlusal force.

Kepeng Zhou [44] completed 16 proposed beam-column intermediate level end node members under the condition that the minimum construction requirements of the current code were met, and the strain distribution of the reinforcement was measured by using the method of embedding resistance strain gauges in slots on the surface of the reinforcement, with the reinforcement strength grade, concrete strength, protective layer thickness, hoop configuration, axial compression ratio, and node form as variables. The results of the study show that: all the proposed corner column node members suffer from side protective layer spalling damage; the anchorage capacity of bending reinforcement after yielding increases with the increase of axial pressure ratio, yield strength of reinforcement, and lateral restraint degree; under the most unfavorable conditions, the anchorage length of bending reinforcement that meets the requirements of our code cannot meet the requirements of reinforcement strength to yield ratio of 1.25. It is found that our code does not meet the requirements of seismic code for the anchorage of reinforcement. In order to meet the requirements of seismic code for the anchorage of reinforcement, it is suggested to add correction factor k for anchorage length of bent reinforcement. The 90° bending of reinforcement is a common mechanical anchorage method, which is widely used in reinforced concrete frame beam-column edge nodes to solve the anchorage length design problem that the height of the column section is not enough to provide sufficient anchorage length of straight reinforcement to achieve its design strength. The anchorage of reinforcement is extremely important in engineering practice, and when the connection length of reinforcement to concrete does not meet the requirements, anchorage can be selected to meet the design requirements.

Yi Ye [45] et al. In order to study the size and proportion of anchorage bearing capacity of each part of the bent reinforcement, by choosing the end bent 90° reinforcement, PVC sleeves were placed in each anchorage section of the bent reinforcement to eliminate the adhesion between the reinforcement and concrete, and the purpose of separating the anchorage bearing capacity was achieved through mutual comparison test. The test used HRB500 grade reinforcement as the anchorage reinforcement and completed 9 sets of mutual comparison tests with its horizontal projection length, bending radius, vertical projection length, and hoop spacing as variables, for a total of 36 anchorage performance tests of bending reinforcement in the beam-column end nodes of reinforced concrete frame intermediate floors. It was found that increasing the bending radius, horizontal projection length and vertical projection length could improve the anchorage strength of bending reinforcement, and the degree of influence was decreased in order. The degree of influence of increasing the radius of bend and horizontal

projection length is much higher than that of changing the vertical projection length.

Although the anchorage strength of the reinforcement can be significantly improved after bending, it may not meet the design requirements at any time, Yong Chen [3] In order to reduce the anchorage length of the reinforcement, alleviate the overdensity of the reinforcement in the node area, and avoid the uncompact concrete pouring, the anchorage plate, as a new form of mechanical anchorage, is gradually applied in reinforced concrete structural engineering. One hundred and eleven reinforced concrete pull-out specimens, including 15 straight reinforcement specimens and 96 anchorage plate specimens, were designed, and the effects of concrete strength, anchorage length, protective layer thickness, and hoop ratio on the bond-slip performance were investigated by comparative analysis. According to the test, the anchorage plate can not only improve the anchorage performance but also reduce the slip between the reinforcement and concrete, which can increase the ultimate bearing capacity by about 20%, and the anchorage strength of the specimens with anchorage plate increases with the increase of concrete tensile strength and protective layer thickness, while a certain degree of the hoop will also improve the anchorage strength. The calculation formula of anchorage strength of reinforcement with anchor plate is proposed.

Yong Chen's[3] test understood the influence of various influencing factors on the anchorage strength when the reinforcement end with an anchor plate, which solved the influencing factors of anchorage, but did not compare with the anchorage performance of straight steel reinforcement can be compared. In order to further understand and compare the anchorage performance of anchor plate reinforcement and straight reinforcement, and analyze the influence of different factors on the anchorage strength of anchor plate reinforcement and the distribution law of anchorage force, Yao Wang [46] used a drawing test, and the drawing reinforcement was made of HRB400 hot-rolled ribbed steel bars with nominal diameters of 18mm, 20mm, and 25mm, and the hoop diameter was 6mm, and the spacing was different according to the matching hoop rate C30, C35, C40 (C30 means: the compressive strength value of concrete cube of 150mm*150mm*150mm is 30Mpa) commercial concrete, the effects of concrete strength, anchorage length, protective layer thickness, hoop rate and other factors on the anchorage strength of reinforcement with anchor plate were investigated. It was found that delaying the damage of concrete is the key to improve the ultimate bearing capacity of anchor plate reinforcement specimens, and increasing the thickness of protective layer or configuring transverse hoop can prevent the concrete from splitting damage and improve the ductility of specimens. The reinforcement with anchor plate can effectively reduce the relative slip of reinforcement and concrete and improve the anchorage performance, which can improve the ratio about 20%. The anchorage strength increases with the increase of concrete tensile strength and relative protective layer thickness, and decreases with the increase of relative anchorage length; increasing the hoop ratio within a certain range can increase the anchorage strength to a larger extent.

The first two tests not only studied the influencing factors of anchorage, but also compared the anchorage performance of straight reinforcement and anchor plate reinforcement, but did not clarify the distribution relationship between anchorage reinforcement and anchor plate. In order

to know the intrinsic connection between anchorage plate and reinforcement more clearly and distinctly, Tianming Miao [47] set end plates at the end of reinforcement, which can effectively reduce the anchorage length of reinforcement in concrete. To study the distribution of the anchorage force of the reinforcement between the bonding action of the reinforcement in the straight anchor section and the bearing action of the end plate, pull-out tests were completed on 120 reinforced concrete prismatic specimens with the end plate of cross-sectional size 150 mm × 150 mm, and the reinforcement with end plate was arranged on the shaped center line of the cross-section. The specimens were subjected to longitudinal reinforcement HRB500 bars and HRB600 bars with three nominal diameters of 20mm, 22mm and 25mm respectively. The concrete strength classes of the specimens were divided into five types: C30, C40, C50, C60, and C70 (C30 means: the compressive strength value of a concrete cube of 150mm*150mm*150mm is 30Mpa). The effects of different nominal diameters d , yield strength f_y , anchorage length l_{ah} , and concrete strength on the anchorage performance of the bars were analyzed to obtain the distribution of anchorage force between the bonding action of the bars in the straight anchor section and the bearing action of the end plate when the bars were yielded in tension. It was found that the ratio of the compression effect of the reinforcement end plate to the anchorage force of the reinforcement decreased linearly with the increase of the relative anchorage length l_{ah}/d (l_{ah} denotes: rebar anchorage length, d denotes: rebar diameter) of the reinforcement with end plate, and increased linearly with the increase of the ratio of the yield strength f_y of the reinforcement to the tensile strength f_t of the concrete f_y/f_t . The effect of the anchorage length of reinforcement with end plates on the bonding action of the straight anchor section reinforcement is still greater. Therefore, it can be found that the effects of concrete strength grade, nominal diameter of reinforcement, and concrete protective layer thickness on the bonding action of reinforcement in the straight anchor section are very limited.

5. CONCLUSION

In this paper, through the introduction of domestic research on the reinforcement-concrete bond test, lap test, and anchorage test in recent years, subsequent researchers can have a clearer and more definite understanding of the existing research status of existing reinforcement-concrete, thus reducing the research time. This paper also introduces the methods of relevant experimental research and the advantages and disadvantages of each research method. It can be found that the bond test is appropriate to use the central pull-out test, the beam test is appropriate for reinforcement subjected to the joint action of tensile force, shear force, and bending moment, and the axial tensile test can be used to simulate the bond characteristics between cracks in purely bending sections of beams. According to the existing research, it can be seen that the research between reinforcement - concrete mostly stays between 14mm-25mm diameter of reinforcement, but for housing construction, the diameter of reinforcement used in slabs is mostly 8-12mm, but there is very little research on 8-12mm reinforcement, and subsequent researchers can study along this direction.

References

- [1] Zheng Shanlock, Pei Pei, Zhang Yixin, et al. A review of research on bond-slip of reinforced concrete[J]. *Materials Guide*, 2018,32(23):4182-4191.
- [2] Zhao M, Su SQ, Zhou XM, et al. Problems related to bond-slip of reinforced concrete [J]. *Construction Technology*, 2009,38(S1):5-9.
- [3] Chen Y, Zou SONGZHE, Yu JX, et al. Study on the slip performance of reinforcement bonded to concrete with anchor plates [J]. *Building Structures*, 2021,51(S1):1350-1355.
- [4] Behavior and Durability Evaluation of Recycled Aggregate Pervious Concrete[J].
- [5] Choi W, Jang S, Yun H. Bond and cracking behavior of lap-spliced reinforcing bars embedded in hybrid fiber reinforced strain-hardening cementitious composite (SHCC)[J]. *Composites Part B: Engineering*, 2017,108:35-44.
- [6] Choi H B, Kang K I. Bond behavior of deformed bars embedded in RAC[J]. *Magazine of Concrete Research*, 2008,60(6):399-410.
- [7] Kim S, Yun H, Park W, et al. Bond strength prediction for deformed steel rebar embedded in recycled coarse aggregate concrete[J]. *Materials & Design*, 2015,83:257-269.
- [8] Lee J. Bonding behavior of lap-spliced reinforcing bars embedded in Ultra-high Strength Concrete with steel fibers[J]. *KSCE Journal of Civil Engineering*, 2016,20(1):273-281.
- [9] Kim S, Yun H. Evaluation of the bond behavior of steel reinforcing bars in recycled fine aggregate concrete [J]. *Cement and Concrete Composites*, 2014,46:8-18.
- [10] Arezoumandi M, Steele A R, Volz J S. Evaluation of the Bond Strengths Between Concrete and Reinforcement as a Function of Recycled Concrete Aggregate Replacement Level[J]. *Structures*, 2018,16:73-81.
- [11] Rakhshanimehr M, Esfahani M R, Kianoush M R, et al. Flexural ductility of reinforced concrete beams with lap-spliced bars[J]. *Canadian Journal of Civil Engineering*, 2014,41(7):594-604.
- [12] Senthil K, Aswa S, Aswin C P. Influence of concrete strength and diameter of reinforcing bar on pullout tests using finite element analysis[J]. *Journal of Structural Engineering & Applied Mechanics*, 2018,1(3):105-116.
- [13] Karatas M, Turk K, Ulucan Z C. Investigation of the bond between lap-spliced steel bar and self-compacting concrete: The role of silica fume[J]. *Canadian Journal of Civil Engineering*, 2010,37(3):420-428.
- [14] Karatas M, Turk K, Ulucan Z C. Investigation of the bond between lap-spliced steel bar and self-compacting concrete: The role of silica fume[J]. *Canadian Journal of Civil Engineering*, 2010,37(3):420-428.
- [15] Elavarasi D, Saravana Raja Mohan K. On low-velocity impact response of SIFCON slabs under drop hammer impact loading[J]. *Construction and Building Materials*, 2018,160:127-135.
- [16] Robert Prince M J, Gaurav G, Singh B. Splice strength of deformed steel bars embedded in recycled aggregate concrete[J]. *Structures*, 2017,10:130-138.
- [17] Prince M J R, Gaurav G, Singh B. Splice strength of steel reinforcement embedded in recycled aggregate concrete[J]. *Construction and Building Materials*, 2018,160:156-168.
- [18] Breccolotti M, Materazzi A L. Structural reliability of bonding between steel rebars and recycled aggregate concrete[J]. *Construction and Building Materials*, 2013,47:927-934.
- [19] Rafi M M. Study of Bond Properties of Steel Rebars with Recycled Aggregate Concrete.

-
- Analytical Modeling[J]. *Strength of Materials*, 2019,51(1):166-174.
- [20] Hwang H, Park S Y. A study on the flexural behavior of lap-spliced cast-in-place joints under static loading in ultra-high performance concrete bridge deck slabs[J]. *Canadian Journal of Civil Engineering*, 2014,41(7):615-623.
- [21] Al-Quraishi H, Al-Farttoosi M, AbdulKhudhur R. Tension Lap Splice Length of Reinforcing Bars Embedded in Reactive Powder Concrete (RPC)[J]. *Structures*, 2019,19:362-368.
- [22] Santana Rangel C, Amario M, Pepe M, et al. Tension stiffening approach for interface characterization in recycled aggregate concrete[J]. *Cement and Concrete Composites*, 2017,82:176-189.
- [23] Qin, Shuai. Analytical model and experimental study of the bond-slip relationship between reinforced concrete[D]. Guangxi University, 2021.
- [24] Zhou Kepeng, Yi Weijian, Zhou Yun. Experimental study on the anchorage performance of bending reinforcement in reinforced concrete frame end nodes[J]. *Journal of Building Structures*, 2022:1-12.
- [25] Chen Jianping, Xu Xunqian, Bao Hua. Current status of research on bond-slip properties of reinforced concrete [J]. *Journal of Nantong University (Natural Science Edition)*, 2004(04):51-56.
- [26] Xu Youlin, Shen Wendu, Wang Hong. Experimental study on the anchorage performance of reinforced concrete bond [J]. *Journal of Building Structures*, 1994(03):26-37.
- [27] Li Xinxing, Zhou Quan, Li Shuisheng. Study on the slip performance and intrinsic structure relationship between steel and UHPC bond: China Civil Engineering Society 2021 Annual Conference [C], Changsha, Hunan, China, 2021.
- [28] Xu Youlin Shao Zhuo Min Shen Wendu. Bonding and anchorage strength of reinforcement to concrete [J]. *Construction Science*, 1988(04):8-14.
- [29] Zhao Yu Xi Jin Wei Liang. Experimental study on the relationship between reinforcement and concrete bonding principal structure [J]. *Journal of Building Structures*, 2002(01):32-37.
- [30] Gao Xiangling, Li J. Numerical simulation of the bonded intrinsic structure relationship between reinforcement and concrete [J]. *Journal of Computational Mechanics*, 2005(01):73-77.
- [31] Xu Youlin. Analytical study on the bonding and anchoring of reinforcement to concrete [J]. *Construction Science*, 1992(04):18-24.
- [32] Zhuang, Binbin, Xiao, Fernando, Liu, Qiang, et al. Experimental study on the bond-slip mechanical properties between concrete with different admixtures and rusted reinforcement [J]. *Silicate Bulletin*, 2022,41(08):2767-2773.
- [33] Wang, Jinlin. Calculation of anchorage length of tensile reinforcement [J]. *Construction workers*, 2013,34(07):42-43.
- [34] Du F, Xiao JZ, Gao XL. Research on test methods for bonding between reinforcement and concrete [J]. *Structural Engineer*, 2006(02):93-97.
- [35] Xiao Jianzhuang, Li Pisheng, Qin Wei. Bond slip performance between recycled concrete and steel reinforcement [J]. *Journal of Tongji University (Natural Science Edition)*, 2006(01):13-16.
- [36] Lv Ying. Study on the anchorage and indirect lap performance of reinforcement in laminated slabs [D]. Tsinghua University, 2019.
- [37] Zhang Y, Chen M. Experimental Study on the Bonding and Anchorage Properties of Reinforcing Steel and Concrete: The Twenty-eighth Annual Meeting of the Beijing Mechanics

Society [C], Beijing, China, 2022.

[38] Zhao Weiping, Xiao Jianzhuang. The ontological model of bond-slip between ribbed reinforcement and concrete[J]. *Engineering Mechanics*, 2011,28(04):164-171.

[39] Zhao M. H., Ye C. Q., Wei J. J., et al. Structural reliability analysis of steel-recycled aggregate concrete bond[J]. *Journal of Bengbu College*, 2022,11(05):8-14.

[40] An XZ, Wang LX, Jiang YJ, et al. Experimental study on the bonding performance of deformed reinforcement with recycled concrete [J]. *Journal of Hebei Engineering University (Natural Science Edition)*, 2022,39(01):60-64.

[41] Pan Shangjie. Analysis of force transfer of lapped reinforcement at horizontal splice of laminated slab shear wall structure [D]. *Anhui University of Architecture*, 2021.

[42] Mei Yu'an, Tian Shui, Gu Qian, et al. Study on the strength of indirect lap joint bond based on statistical analysis[J]. *Journal of the Wuhan University of Technology*, 2022,44(09):58-63.

[43] Yang Fan. Study on flexural performance of indirect lap joint reinforced concrete beams[D]. *Hunan University*, 2020.

[44] Zhou Kepeng, Yi Weijian, Zhou Yun. Experimental study on the anchorage performance of bending reinforcement in reinforced concrete frame end nodes[J]. *Journal of Building Structures*, 2022:1-12.

[45] Ye Y. Experimental study on anchorage performance of 90° bending reinforcement [D]. *Hunan University*, 2021.

[46] Wang Yao. Experimental study on the anchorage performance of HRB400 steel bars with anchor plates [D]. *Zhengzhou University*, 2021.

[47] Miao Tianming. Study on the anchorage force of reinforcement with end plates and the local compression load-bearing capacity under end plates[D]. *Harbin Institute of Technology*, 2020.