

Review on reinforcement-concrete bonded anchorage

ABSTRACT

In order to obtain the study of the bonding properties between the reinforcement-concrete and give full play to the material properties, a lot of research has been carried out on reinforcement-concrete. Existing reinforcement-concrete studies contain mainly reinforcement-concrete bond, reinforcement lap and anchorage of reinforcement. The reinforcement-concrete bond test mainly measures the bond slip curve between the two to determine the bond strength between reinforcement and concrete. The reinforcement lap test is to study the lap performance between the reinforcement and the reinforcement. The anchorage test of reinforcement is conducted to study the reduction of the connection length between reinforcement and concrete while meeting the force requirements. According to a large number of tests, the bond strength of the reinforcement is affected by the shape of the mixed reinforcement, the thickness of the protective layer of the diameter concrete, the spacing of the reinforcement, the transverse reinforcement restraint and the material properties of the reinforcement and concrete. This paper discusses the test methods, influencing factors and the lack of existing research in the study of the performance of reinforcement-concrete bonding, lap and anchorage properties.

Key words: reinforcement-concrete, bond, lap, anchorage

1. Introduction

Reinforced concrete is a composite material made by combining two materials with different physical and mechanical properties, steel and concrete [1], and its intrinsic model is complex [2]. The bond-slip performance of steel and concrete has been a hot topic of research [3-15], but there are due to its many influencing factors, different test methods, etc. resulting in different variability of test results. This paper presents the existing domestic research on reinforcement-concrete bonding and anchorage etc. in recent years to provide a reference for the subsequent research.

2. Steel - concrete bonding study

There are three existing test methods to study the bond between reinforcement-concrete, which are pull-out test (Figure 1), beam test (Figure 2) and axial tensile test. The pull-out test is mainly used to measure the bond stress and relative slip of the reinforcement-concrete, when

the bond strength of the reinforcement-concrete is high, the specimen is more splitting damage, and therefore does not fully reflect the bond performance between the reinforcement and concrete, but because the specimen is easy to make and test the characteristics of the test method is widely used. Beam test specimens are not only subjected to tension, but also to shear and bending moment, so the beam test method is more suitable for the bond anchorage test at the end of the beam. The shortcomings of the beam test are the large size of the specimen, the high production cost and the complexity of the test. The axial tensile test can measure the inter-seam bond force and relative slip, and is generally used to simulate the bond characteristics between cracks in purely curved sections of beams, in contrast to axial tensile specimens which are not suitable for the study of bond slip curves between reinforcement-concrete.

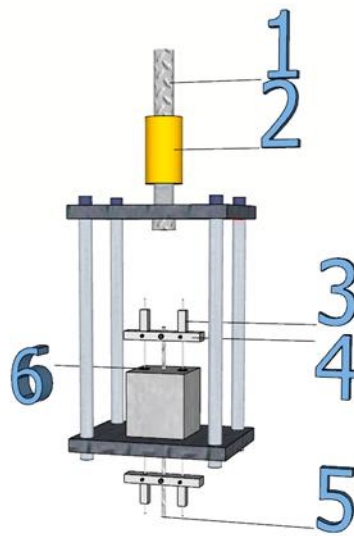

1 - upper chuck 2 - force transducer 3 - displacement meter
4 - displacement meter bracket 5 - lower chuck 6 - glass sheet

Figure 1: Bond test pull-out test loading schematic

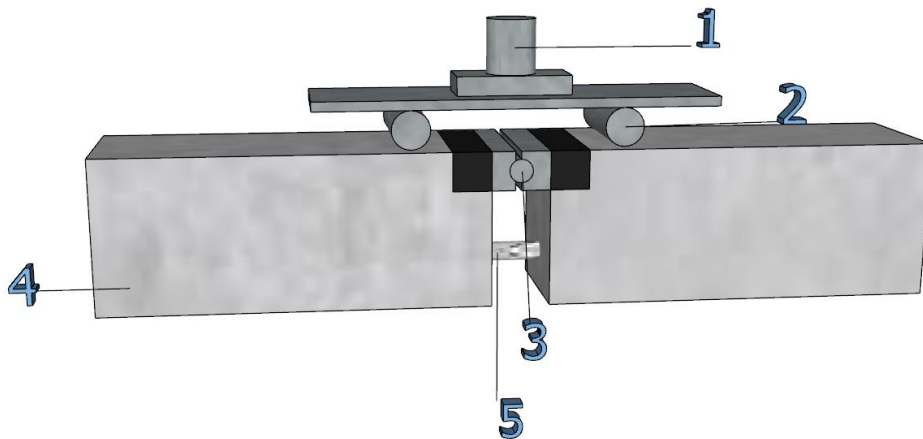

1- Upper loading device 2-Loading distribution point 3-Turning hinge
4-Test block 5-Rebar

Figure 2: Schematic diagram of the beam test loading device

The bond strength of the deformed reinforcement is mainly expressed as the mechanical bite between the convex rib on the surface of the reinforcement and the concrete, but at the beginning of the loading mainly by the chemical bonding force and the friction force together, so the slip at the loading end is small when the pulling force is small, and the free end basically has no slip; with the increase of the pulling force, the chemical bonding force is gradually destroyed, and the free end starts to slip; when the pulling force continues to increase, the slip is gradually accelerated, and finally, due to the bite between the convex rib on the surface of the reinforcement and the concrete produces a large transverse tensile stress, which causes the specimen to split. For the specimens without transverse hoops, the relative protection layer is thin and the splitting damage occurs; with the increase of the relative protection layer thickness, the damage form of the specimen changes to the anchor pulling damage; for the specimens with transverse hoops, the splitting damage does not occur because of the restraint of the hoops, and finally the concrete is crushed and the reinforcement is slowly pulled and damaged.

Yong Zhang [16] et al. analyzed the characteristics of reinforcement bond anchorage and the main factors affecting the bond anchorage strength through pull-out tests of 36 reinforcement and concrete bond anchorage specimens. The bond strength was found to increase with the strength of concrete due to the higher compressive strength of higher strength concrete under the action of reinforcement ribs. The influence of diameter on the bond strength was not significant when the diameter of the reinforcement was less than 16 mm, and the bond strength decreased significantly when the diameter was greater than 20 mm. The bond stress in the straight anchor section of the specimen with relatively long anchorage length is not uniformly distributed along the reinforcement, and the average bond stress is lower, while the bond stress in the straight anchor section of the specimen with small anchorage length is uniform and

plentiful, and the average bond stress is higher, so the bond strength of the specimen decreases as the anchorage length increases. Weiping Zhao [17] et al. explained the reinforcement-concrete bond-slip intrinsic model through analysis, explaining that the reason for the existence of the falling section of the curve is that when the concrete occlusal teeth between the ribs are sheared off, the transmission mechanism of the tapered wedge action no longer exists. As the reinforcement with inter-rib filled concrete is slowly pulled out, the bond stress decreases rapidly. The main reasons for this are twofold: first, the sheared concave-convex interface is gradually frustrated cementite particles grinding fine, grinding fine particles in the interface rolling thus leading to a negative exponential decay of the friction coefficient, the frictional resistance is reduced, the second, with the increase in the amount of slip concrete powder is constantly brought out, will lead to a reduction in the contact surface pressure. Minghua Zhao [18] et al, used 14m diameter HRB400 grade reinforcement, concrete test 200mm*200mm*150mm by pull-out test to compare the results of experimental study of bond strength of natural aggregate and recycled aggregate concrete, the results show that the normalized bond strength is little affected by the factor that recycled aggregate replaces normal aggregate, meanwhile by calculating the design anchorage length provided by standards such as hair MC2010 and EC2 can be applied to RAC. Xinzheng An [19] et al. selected HRB400E reinforcement using a center-drawing test to investigate the bond performance of recycled concrete with 100% recycled coarse aggregate replacement, by varying the recycled fine aggregate replacement rate (0%, 30%, 50%, 70%, 100%) and reinforcement diameter (12mm, 14mm, 18mm), and designing 72 150mm*150mm* 150mm center-drawn specimens, in which the effective bond lengths were all 5D, with PVC sleeves at both ends and sealed, it was found that the ultimate bond stress and initial bond stiffness of reinforcement-recycled concrete decreased with the increase of recycled fine aggregate replacement rate and reinforcement diameter.

3. Reinforced-concrete lap joint study

Reinforcing steel - concrete lap test as a special form of bond test, the lap performance between the reinforcing steel largely determines the anchorage length of the reinforcing steel. The lap joint of reinforcement in the steel-concrete bonding is tied lap joint and indirect lap joint, of which indirect lap joint is again one of the important forms of reinforcement connection in the assembly building. Tie lap is the reinforcement tied together with ties, and indirect lap is a certain distance between the reinforcement. There are usually 2 methods of lap joint test, which are two bars lap joint method (Figure 3) and four bars lap joint method (Figure 4), two bars lap joint method loading method is to pull 2 bars, and four bars lap joint method using 2 bars on one side connected together with connectors and then pull, four bars lap joint method and two lap joint method can eliminate the eccentric force generated by its pull test.

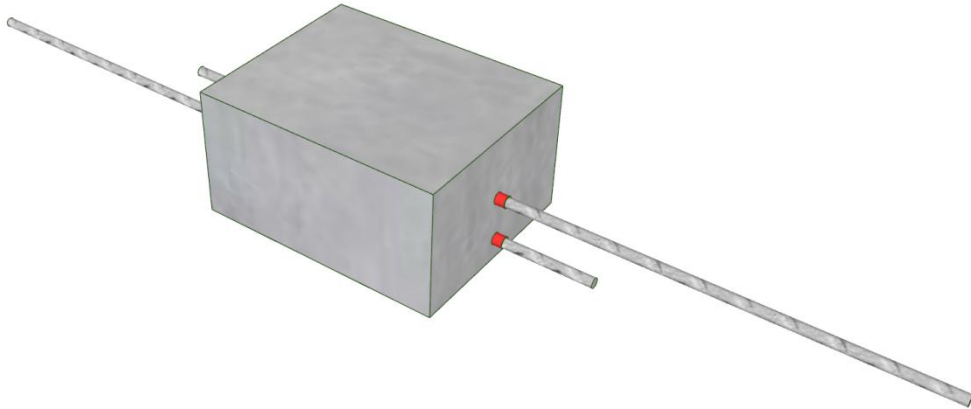

Figure 3: Double reinforcement lap test

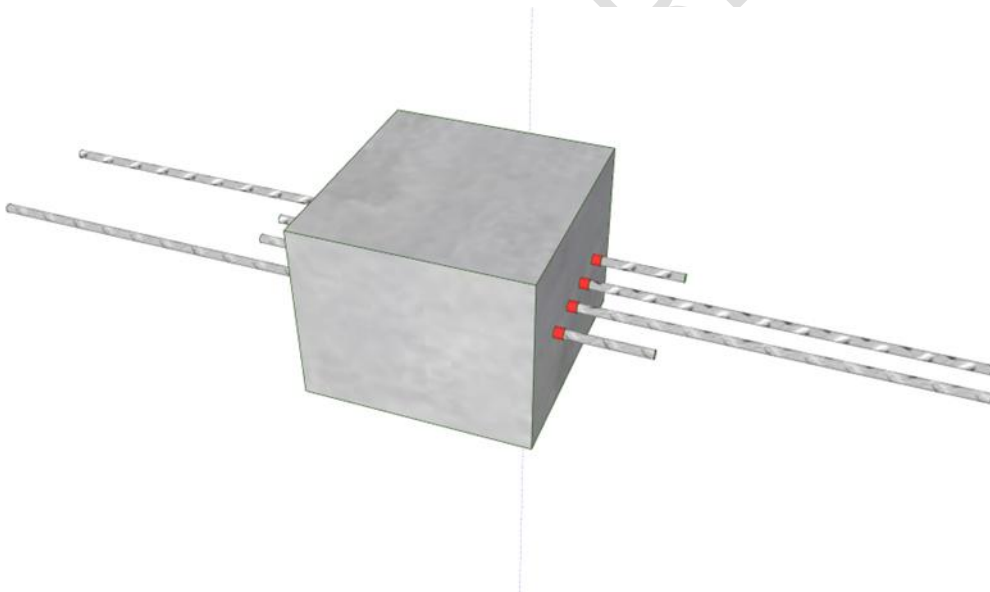

Figure 4: Four rebar lap test

Yu'an Mei [20] et al. obtained by statistical analysis that the bond strength of lapped reinforcement and grout increased with the increase of split tensile strength of grout, protective layer thickness and volumetric hoop ratio, and decreased with the increase of lap length of reinforcement, while the effect of net distance of reinforcement on bond strength was not obvious, and the effect of lap length of reinforcement and volumetric hoop ratio on bond strength was significant. Shangjie Pan [21] et al. studied the principle and method of lap structure of lapped reinforcement out of horizontal splice lap of stacked slab shear wall, in order to study the force transfer efficiency of lap reinforcement at horizontal splice of stacked slab shear wall structure and its stress-strain situation, two groups of shear wall horizontal splice

reinforcement lap specimens were designed and designed as 1 and 2 bars lap, the diameter of selected 1 steel lap reinforcement was Through the test, the stress-strain of lap bars at the horizontal splice of the laminated slab shear wall with different structural measures was studied and analyzed; the stress transfer efficiency of indirect lap bars and the damage pattern of the specimens. It was found that the single-row lap splice specimens and double-row lap splice specimens at the horizontal splice were damaged in tension at approximately the same location, and the damage pattern of the upper end of the single-row lap splice specimens was better without large cracks, while the upper end of the double-row lap splice specimens showed obvious cracks. The lower end of the specimens showed different degrees of diagonal tensile damage mainly because the protective layer thickness of the longitudinal tensile reinforcement in the prefabricated slab was insufficient. The yield points and ultimate values of the single-row lapped 16 mm reinforcement specimens and the double-row lapped 12 mm specimens were basically the same, and their displacement load curves were basically consistent. The although studied the lap performance of different steel bars when indirectly lapped, the test rebar lap length was too long and the lap performance of the rebar was excessive, failing to make reasonable use of the material, and the collective condition of the rebar could not be obviously known, thus the lap performance of the rebar could not be clearly reflected. Ying Lv [22] studied the indirect lap of reinforcement in the plate, considering one to one (i.e. one additional reinforcement one prefabricated base plate reinforcement) pulling test exists eccentric force, thus the design is two to two (i.e. each group of specimens contains 2 groups of lap bars), through the test it was found that when the lap length is 0.8 l_a of the lap length specified in GB50010, it can also meet the force requirements, and the diameter size changes in a small range No significant effect on the indirect lap strength.

In order to study the lap performance of indirect lap reinforcement in concrete and the influencing factors, Fan Yang [23] designed 24 beams, considering the loading method, reinforcement diameter, lap reinforcement spacing, and hoop restraint factors, so the loading methods were designed with four-point loading and three-point loading, the reinforcement diameters were selected as 18mm and 25mm, the lap reinforcement spacing was selected as 0, 2 times the reinforcement diameter, and 4 times the lap reinforcement. According to the test results, the indirect lap has influence compared with the contact lap, and the size of the influence depends on whether there are hoops or not, when there are hoops, the ultimate stress of the reinforcement increases with the increase of the lap spacing, when the indirect lap spacing is 4D, the ultimate stress is increased by 33%. When there is no hoop, the effect is not significant. The restraint effect of hoop can significantly improve the bond strength of the reinforcement, and the three-point loading method has a significant increase of about 30% in the stress of the reinforcement compared with the four-point loading method.

4. Anchorage study of steel-concrete

The factors affecting the anchorage of reinforcement are divided into the following: First, there is a chemisorption force on the building surface, that is, there is a bonding force between the concrete and the surface of the reinforcement. Second, the structure of the building project is in a state of stress, the concrete and the surface of the reinforcement will form a friction force, and

this force is correlated with the contact roughness of the concrete as well as the reinforcement. Third, the mechanical bite force. The surface of concrete and reinforcement is uneven, thus creating an occlusal force. Kepeng Zhou [24] completed 16 proposed beam-column intermediate level end node members under the condition that the minimum construction requirements of the current code were met, and the strain distribution of the reinforcement was measured by using the method of embedding resistance strain gauges in slots on the surface of the reinforcement, with the reinforcement strength grade, concrete strength, protective layer thickness, hoop configuration, axial compression ratio, and node form as variables. The results of the study show that: all the proposed corner column node members suffer from side protective layer spalling damage; the anchorage capacity of bending reinforcement after yielding increases with the increase of axial pressure ratio, yield strength of reinforcement and lateral restraint degree; under the most unfavorable conditions, the anchorage length of bending reinforcement that meets the requirements of our code cannot meet the requirements of reinforcement strength to yield ratio of 1.25. It is found that our code does not meet the requirements of seismic code for anchorage of reinforcement. In order to meet the requirements of seismic code for anchorage of reinforcement, it is suggested to add correction factor k for anchorage length of bent reinforcement. The 90° bending of reinforcement is a common mechanical anchorage method, which is widely used in reinforced concrete frame beam-column edge nodes to solve the anchorage length design problem that the height of column section is not enough to provide sufficient anchorage length of straight reinforcement to achieve its design strength. The anchorage of reinforcement is extremely important in engineering practice, and when the connection length of reinforcement to concrete does not meet the requirements, anchorage can be selected to meet the design requirements. Yi Ye [25] et al. In order to study the size and proportion of anchorage bearing capacity of each part of the bent reinforcement, by choosing the end bent 90° reinforcement, PVC sleeves were placed in each anchorage section of the bent reinforcement to eliminate the adhesion between the reinforcement and concrete, and the purpose of separating the anchorage bearing capacity was achieved through mutual comparison test. The test used HRB500 grade reinforcement as the anchorage reinforcement, and completed 9 sets of mutual comparison tests with its horizontal projection length, bending radius, vertical projection length and hoop spacing as variables, for a total of 36 anchorage performance tests of bending reinforcement in the beam-column end nodes of reinforced concrete frame intermediate floors. It was found that increasing the bending radius, horizontal projection length and vertical projection length could improve the anchorage strength of bending reinforcement, and the degree of influence was decreasing in order. The degree of influence of increasing the radius of bend and horizontal projection length is much higher than that of changing the vertical projection length.

Although the anchorage strength of the reinforcement can be significantly improved after bending, it may not meet the design requirements at any time, Yong Chen [26] In order to reduce the anchorage length of the reinforcement, alleviate the overdensity of the reinforcement in the node area, and avoid the uncompact concrete pouring, the anchorage plate, as a new form of mechanical anchorage, is gradually applied in reinforced concrete structural engineering. One hundred and eleven reinforced concrete pull-out specimens, including 15 straight reinforcement specimens and 96 anchorage plate specimens, were

designed, and the effects of concrete strength, anchorage length, protective layer thickness and hoop ratio on the bond-slip performance were investigated by comparative analysis. According to the test, the anchorage plate can not only improve the anchorage performance but also reduce the slip between the reinforcement and concrete, which can increase the ultimate bearing capacity by about 20%, and the anchorage strength of the specimens with anchorage plate increases with the increase of concrete tensile strength and protective layer thickness, while a certain degree of hoop will also improve the anchorage strength. The calculation formula of anchorage strength of reinforcement with anchor plate is proposed.

Yong Chen's [26] test understood the influence of various influencing factors on the anchorage strength when the reinforcement end with anchor plate, which solved the influencing factors of anchorage, but did not compare with the anchorage performance of straight steel reinforcement can be compared. In order to further understand and compare the anchorage performance of anchor plate reinforcement and straight reinforcement, and analyze the influence of different factors on the anchorage strength of anchor plate reinforcement and the distribution law of anchorage force, Yao Wang [27] used a drawing test, and the drawing reinforcement was made of HRB400 hot-rolled ribbed steel bars with nominal diameters of 18mm, 20mm, and 25mm, and the hoop diameter was 6mm, and the spacing was different according to the matching hoop rate C30, C35, C40 commercial concrete, the effects of concrete strength, anchorage length, protective layer thickness, hoop rate and other factors on the anchorage strength of reinforcement with anchor plate were investigated. It was found that delaying the damage of concrete is the key to improve the ultimate bearing capacity of anchor plate reinforcement specimens, and increasing the thickness of protective layer or configuring transverse hoop can prevent the concrete from splitting damage and improve the ductility of specimens. The reinforcement with anchor plate can effectively reduce the relative slip of reinforcement and concrete and improve the anchorage performance, which can improve the ratio about 20%. The anchorage strength increases with the increase of concrete tensile strength and relative protective layer thickness, and decreases with the increase of relative anchorage length; increasing the hoop ratio within a certain range can increase the anchorage strength to a larger extent.

The first two tests not only studied the influencing factors of anchorage, but also compared the anchorage performance of straight reinforcement and anchor plate reinforcement, but did not clarify the distribution relationship between anchorage reinforcement and anchor plate. In order to know the intrinsic connection between anchorage plate and reinforcement more clearly and distinctly, Tianming Miao [28] set end plates at the end of reinforcement, which can effectively reduce the anchorage length of reinforcement in concrete. To study the distribution of the anchorage force of the reinforcement between the bonding action of the reinforcement in the straight anchor section and the bearing action of the end plate, pull-out tests were completed on 120 reinforced concrete prismatic specimens with end plate of cross-sectional size 150 mm × 150 mm, and the reinforcement with end plate was arranged on the shaped center line of the cross-section. The specimens were subjected to longitudinal reinforcement HRB500 bars and HRB600 bars with three nominal diameters of 20mm, 22mm and 25mm respectively. The concrete strength classes of the specimens were divided into five types: C30, C40, C50, C60

and C70. The effects of different nominal diameters d , yield strength f_y , anchorage length l_{ab} and concrete strength on the anchorage performance of the bars were analyzed to obtain the distribution of anchorage force between the bonding action of the bars in the straight anchor section and the bearing action of the end plate when the bars were yielded in tension. It was found that the ratio of the compression effect of the reinforcement end plate to the anchorage force of the reinforcement decreased linearly with the increase of the relative anchorage length l_{ah}/d of the reinforcement with end plate, and increased linearly with the increase of the ratio of the yield strength f_y of the reinforcement to the tensile strength f_t of the concrete f_y/f_t . The effect of anchorage length of reinforcement with end plates on the bonding action of the straight anchor section reinforcement is still greater. Therefore, it can be found that the effects of concrete strength grade, nominal diameter of reinforcement, and concrete protective layer thickness on the bonding action of reinforcement in the straight anchor section are very limited.

5. CONCLUSION

This paper introduces the study of reinforcement-concrete bond test, lap test and anchorage test, so that the subsequent researchers can understand the existing research status of reinforcement-concrete more clearly and explicitly, and also introduces the methods of relevant experimental research and the advantages and disadvantages of each research method, so that the subsequent researchers can provide a research reference for a more reasonable choice of test methods. According to the existing research, it can be seen that the research between reinforcement-concrete mostly stays between 14mm-25mm diameter of reinforcement, but for housing construction, the most amount of reinforcement is the slab, and the slab is equipped with reinforcement diameter of 8-12mm, but the existing research on such research is very little. In summary, the study of 8-12 mm diameter reinforcement is extremely necessary.

REFERENCES

- [1] Shansuo Zheng, Pei Pei, Yixin Zhang, et al. A review of reinforced concrete bond-slip research [J]. *Materials Guide*, 2018,32(23):4182-4191.
- [2] Ming Zhao, Sanqing Su, Ximao Zhou, et al. Problems related to bond slip of reinforced concrete [J]. *Construction Technology*, 2009,38(S1):5-9.
- [3] Shuai Qin. Analytical model and experimental study of bond-slip relationship between reinforced concrete [D]. Guangxi University, 2021.
- [4] Binbin Zhuang, Chaoxiong Xiao, Qiang Liu, et al. Experimental study on the bond-slip mechanical properties between concrete with different admixtures and rusted steel bars[J]. *Silicate Bulletin*, 2022,41(08):2767-2773.
- [5] Kaipeng Zhou, Weijian Yi, Yun Zhou. Experimental study on the anchorage performance of bending reinforcement in reinforced concrete frame end nodes[J]. *Journal of Building Structures*, 2022:1-12.
- [6] Jianping Chen, Xunqian Xu, Hua BAO. Current status of research on bond-slip properties of reinforced concrete [J]. *Journal of Nantong University (Natural Science Edition)*, 2004(04):51-56.
- [7] Youlin Xu, Wendu Shen, Hong Wang. Experimental study on the anchorage performance of reinforced concrete bond [J]. *Journal of Building Structures*, 1994(03):26-37.
- [8] Xinxing Li, Quan Zhou, Shuisheng Li. Study on the slip performance and intrinsic structure relationship between steel and UHPC bond: China Civil Engineering Society 2021 Annual Conference [C], Changsha, Hunan, China, 2021.
- [9] Youlin Xu, Zhuomin Shao, Wendu Shen. Bonding and anchorage strength of reinforcement and concrete [J]. *Construction Science*, 1988(04):8-14.
- [10] Feng Du, Jianzhuang Xiao, Xiangling Gao. Study on the test method of bonding between reinforcement and concrete [J]. *Structural Engineer*, 2006(02):93-97.
- [11] Wang Jinlin. Calculation of anchorage length of tensile reinforcement [J]. *Construction workers*, 2013,34(07):42-43.
- [12] Yuxi Zhao, Weiliang Jin. Experimental study on the relationship between reinforcement and concrete bonding principal structure [J]. *Journal of Building Structures*, 2002(01):32-37.
- [13] Xiangling Gao. Numerical simulation of the principal structure relationship between reinforcement and concrete bond[J]. *Journal of Computational Mechanics*, 2005(01):73-77.
- [14] Youlin Xu. Analytical study on the bonded anchorage of reinforcement to concrete [J]. *Construction Science*, 1992(04):18-24.
- [15] Jianzhuang Xiao, Pisheng Li, Wei Qin. Bond slip properties between recycled concrete and reinforcement [J]. *Journal of Tongji University (Natural Science Edition)*, 2006(01):13-16.
- [16] Yong Zhang, Mingliang Chen. Experimental study on the bonding and anchoring properties of reinforcement and concrete: The 28th Annual Meeting of the Beijing Mechanics Society [C], Beijing, China, 2022.
- [17] Weiping Zhao, Jianzhuang Xiao. Ontological model of bond slip between ribbed reinforcement and concrete[J]. *Engineering Mechanics*, 2011,28(04):164-171.
- [18] Minghua Zhao, Changqing Ye, Jinjin Wei, et al. Structural reliability analysis of

-
- steel-recycled aggregate concrete bond[J]. Journal of Bengbu College, 2022,11(05):8-14.
- [19] Xingzheng An, Lixin Wang, Yujin Jiang, et al. Experimental study on the bonding performance of deformed reinforcement with recycled concrete [J]. Journal of Hebei Engineering University (Natural Science Edition), 2022,39(01):60-64.
- [20] Yu'an Mei, Shui Tian, Qian Gu, et al. Study on the strength of indirect lap bond based on statistical analysis[J]. Journal of Wuhan University of Technology, 2022,44(09):58-63.
- [21] Shangjie Pan. Analysis of force transfer of lap bars at horizontal splices in laminated slab shear wall structures[D]. Anhui University of Architecture, 2021.
- [22] Ying Lv. Study on the anchorage and indirect lap performance of reinforcement in laminated slabs[D]. Tsinghua University, 2019.
- [23] Fan Yang. Study on flexural performance of indirect lap reinforced concrete beams[D]. Hunan University, 2020.
- [24] Kepeng Zhou, Weijian Yi, Yun Zhou. Experimental study on the anchorage performance of bending reinforcement in reinforced concrete frame end nodes[J]. Journal of Building Structures, 2022:1-12.
- [25] Yi YE. Experimental Study on Anchorage Performance of 90° Bent Steel Bar [D]. Hunan University, 2021.
- [26] Yong Chen, Songzhe Zou, Jinshen Yu, et al. Study on bonding and sliding behavior of Reinforced concrete with anchorage plates [J]. Building Structures, 201,51(S1):1350-1355.
- [27] Rao wang. Experimental Study on Anchoring Performance of HRB400 Steel Bar with Anchoring Plate [D]. Zhengzhou University, 2021.
- [28] Tianming Miao. Study on Anchorage Force of Steel Bar with End Plate and Local Bearing Capacity of End Plate [D]. Harbin Institute of Technology, 2020.