

# Development and Testing of Hydrocyclone Separator for Biodiesel

## ABSTRACT

Hydrocyclone is an equipment that uses a cyclone or tangential injection flow process with centrifugal forces to separate liquids of different densities. The denser liquid move downwards in a spiral path into an underflow chamber, while clean liquid which is less dense move upwards to the center of the spiral, towards the top outlet. Colman and Thew's hydrocyclone geometry analysis approached was used in the design and the assumed inlet chamber diameter (D) used for this design was 150 mm and a reducing section length of 1500 mm at a reducing angle of 20°. The capacity of the designed hydrocyclone system in volume is 5.5 liters. The developed machine was tested with 15 liters of palm kernel oil (PKO) as raw material using two different pressures gauge (70 and 80 kPa) and also effect acid concentration (sulphuric acid) at 3 different experimental runs. After the experiments, it was deduced that at constant temperature level, as the pressure rate increases, there is a corresponding increase in the discharge rate at the underflow and overflow outlets where 2.04 minutes and 1.67 minutes were used to separate biodiesel and glycerin under 70 and 80 kPa respectively. Also, it was deduced experimentally that PKO with sulphuric acid gives a higher yield of biodiesel of 47.74% while the one without has 38.49% yield under same experimental and operational conditions.

Keywords: *Hydrocyclone, Glycerol, Biodiesel, Design, Palm Kernel Oil, Cyclone.*

## 1. INTRODUCTION

According to IEA [1,2] report, apart from hydroelectricity and nuclear energy, the majority of the world's energy demands are met by petrochemical sources, coal and natural gases which are limited and might soon run out at current consumption rates. The use of vegetable oil as a fuel source in diesel engines is as old as the diesel engine itself, but the demand to develop and utilize plant oils and animal fats as biodiesel fuels has been limited until recently [3]. Based on research outputs from Petrovsky *et al.* [4], existing technologies allow for the direct conversion of such fuel source into heat or power as well as the production of gaseous, liquid, or solid fuels from such waste; biodiesel, bioethanol, and biogas are seen to have the most promise.

Biodiesel is easy to use, environmentally benign and biodegradable and are created by chemical transesterification of vegetable oil [5]. As the degree of purity impacts the performance of the fuel and the dependability of systems using it, the resulting biodiesel contains contaminants like glycerin or particle matter that need to be separated [6]. Simple and cost effective technologies for separating contaminants should be made available for the process of purification of the mixture produced [7]. According to He *et al.*

[8] engineering wise, hydrocyclones are frequently employed for separating solid-liquid, gas-liquid and liquid-liquid mixtures. For the liquid-liquid case, both dewatering and deoiling methods have been mostly utilized in the oil industry [9]. Hydrocyclones have emerged as an economical and effective alternative for produced water deoiling and other applications over the conventional methods [4]. Looking at the cost implication of installing industrial hydrocyclone with complex operational process, it is important to design a laboratory size low cost hydrocyclone that can be used for experimental purpose. This study focuses on the design of economical and easy to use laboratory size liquid-liquid hydrocyclone (LLHC) to remove glycerol from biodiesel using a conventional gravity based approach.

## **2. METHODOLOGY**

The Alternate Energy Laboratory of the Department of Agricultural Engineering, Federal University of Technology Akure has designed a LLHC for Biodiesel separation. The LLHC hydrocyclone is designed to work using centrifugal forces which acts on suspended particles in the swirling liquid stream [10; 11]. Unlike centrifuges, the designed LLHC machine separates without the need of mechanically moving parts. The only equipment used in this design is a pump and the necessary vortex motion is induced by the fluid itself. Based on density difference, the dense liquid move outward to the hydrocyclone wall, at which they are transported downwards to the apex of the hydrocyclone.

### **2.1 Description of Hydrocyclone**

The low-cost hydrocyclone consists of four major compartments:

- i. the inlet chamber which is a cylindrical type has a designed capacity of 2.5 liters. It comprise of a cylindrical feed chamber which serves to convert the incoming flow to a tangential flow with minimal turbulence.
- ii. the reducing section which is a very important section of the hydrocyclone At this section, there is a movement of the pumped liquid in a particular order which help to allow return and separation of the glycerol from the biodiesel.
- iii. the tapered section which is designed at an angle of  $1.5^\circ$ . The tapered section is incorporated majorly to allow the backward flow of the biodiesel.
- iv. the tail pipe section leads to the underflow. This is the area that delivers the glycerol to the underflow exit. It is characterized with a long, straight cylindrical pipe.

The hydrocyclone uses centrifugal pump and the effect of vortex finder to separate the biodiesel from the glycerol. The glycerol is collected via the underflow exit of the tail pipe section while the biodiesel leaves through the overflow exit. The pump is connected through the inlet chamber section with a pressure gauge attached to determine the pressure at which the pump is jetting the mixture into the inlet chamber. Likewise the vortex finder aids the effective upward flow of the biodiesel. The capacity of the designed hydrocyclone system in volume is 5.5 liters.

### **2.2 Design Calculation for the Hydrocyclone**

The hydrocyclone design calculation was resolved based on Colman and Thew's hydrocyclone geometry analysis and ration following the diagram in image 1. The Colman and Thew [12] geometry was specifically applied in the design of this liquid-liquid hydrocyclone. For the purpose of this research, the diameter of cylindrical inlet section called a characteristics diameter (D). This D is assumed at the initial stage of design calculation and this is the only assumed parameter that resulted to the remaining dimensions of the hydrocyclone component design.

This geometry rations approach has been used in dimension calculation and design of LLHC by different researchers like [13; 14; 15; 16; 11; 4 and 10]. The inlet chamber diameter (D) was assumed as 150 mm and this gave the bases for the design. The ratio for the inlet chamber height to the diameter is given by the formula according to Colman and Thew [12] in Equation 1. The height of the inlet chamber was noted "L<sub>1</sub>" = D = 150 mm.

$$\frac{L_1}{D} = 1 \quad (1)$$

The reducing section which is the next part to the inlet chamber was also designed for with the diameter of the base of the reducing section noted as D<sub>n</sub>. The ratio of the diameter of the base of the reducing section to the diameter of the inlet chamber is 0.5 based on Coleman and Thew's hydrocyclone geometry analysis as seen in Equation 2.

$$\begin{aligned} \frac{D_n}{D} &= 0.5 \\ \frac{D_n}{150} &= 0.5 \\ D_n &= 75 \text{ mm} \end{aligned} \quad (2)$$

The angle of reducing section is  $\alpha$  which geometrically determined using right angle triangle formula.

$$\alpha = 20^\circ$$

The section next to the reducing chamber is the tapered section. The diameter of the base of the tapered section is denoted by D<sub>u</sub> and the ratio of the diameter of the base of the tapered section to that of the diameter of the inlet chamber is 0.25 as expressed in Equation 3

$$\begin{aligned} \frac{D_u}{D} &= 0.25 \\ \frac{D_u}{150} &= 0.25 \\ D_u &= 37.5 \text{ mm} \end{aligned} \quad (3)$$

The reducing angle of the tapered section is noted with the symbol " $\beta$ " = 1.5°. The last section of the hydrocyclone is the tail pipe section. The length of the tail pipe section is noted as L<sub>3</sub> and the ratio of L<sub>3</sub> to D must not be greater than 15 as established by Colman and Thew's hydrocyclone geometry analysis and ration.

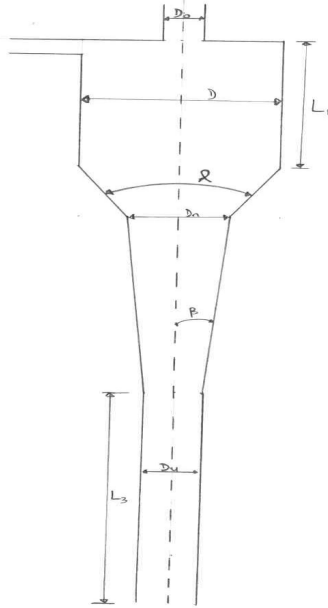

Image 1: Colman and Thew's hydrocyclone geometry analysis and ration

Equations 4, 5 and 6 provide the expression for calculating the length of the tail pipe, tapered angle and diameter of overflow exit pipe as established by Wang *et al.* [17].

$$\frac{L_3}{D} \leq 15 \quad (4)$$

$L_3$  used for this designed is 1500 mm.

$$3.0^\circ < \beta > 0.75^\circ \quad (5)$$

The diameter of the overflow exit pipe is denoted by  $D_0$ . The ratio of the diameter of the overflow exit to that of the diameter of the inlet chamber is

$$\frac{D_0}{D} < 0.05 \quad (6)$$

For this design,  $D_0$  was taken as 7.0 mm.

The Colman and Thew [12] geometry has been applied in this project work with 150 mm diameter of cylindrical inlet section called a characteristics diameter ( $D_c$ ). This  $D_c$  is assumed at the initial stage of design calculation and this is the only assumed parameter that resulted to the remaining dimensions of the hydrocyclone component design.

### 3. RESULTS AND DISCUSSION

The results obtained from the experimental testing of hydrocyclone are discussed in this section. The sectional and pictorial view of the developed hydrocyclone can be seen in Figure 1 and 2 respectively.

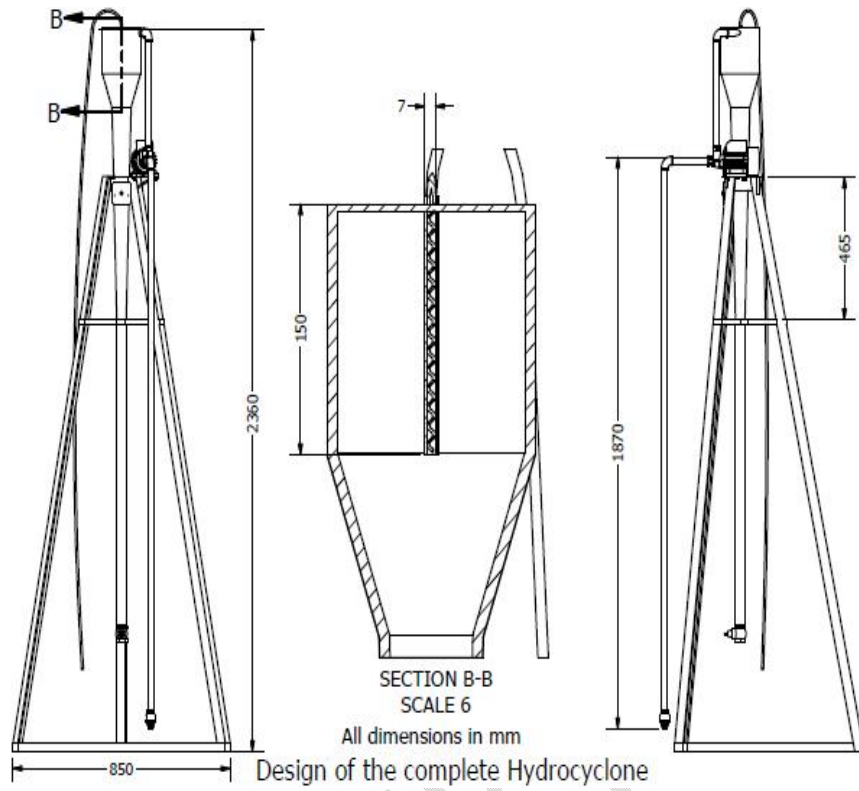

Figure 1: Sectional View of the Designed LLHC



Figure 2: Developed HHLC machine.

### 3.1 Machine Test Procedure

The developed machine was tested using Palm Kernel Oil (PKO) as the biodiesel source. 15 liters of PKO and 3.0 liters of methanol (i.e. 20 % by volume of oil) were utilized in the test batch production. In order to completely remove or reduce the level of FFA in the PKO, sulphuric acid was added to the PKO before pre-heating. 15 liters of palm kernel oil containing 1.87 liters of acid was pre-heated to a steady temperature of 60 °C using a magnetic heater/stirrer. With the aid of the measuring cylinder 3.0 liters of methanol was measured and poured into the beaker. 135.0 g of NaOH pellet was measured using an electronic precision scale (KD-TBE-1200) with a sensitivity of 0.01 g and maximum load of 1200 g and added to the methanol. The content of the beaker was stirred vigorously using Chemglass 135 mm round top analog hot plate stirrer system until the NaOH was completely dissolved in the methanol to form sodium methoxide (CH<sub>3</sub>ONa). The CH<sub>3</sub>ONa was poured into a stainless bucket containing the preheated oil and stirred using the round top analog hot plate stirrer system at a steady temperature of 60 °C (Thermo-hygrometer (CENTER 315) was used to take the temperature reading of the hot oil). This method has been effectively utilized by Ojolo *et al.* [18] and Eze *et al.* [19].

The heating and stirring was stopped after 40 minutes and the product was poured into another container through which the pre-heated mixture is transferred via a centrifugal pump (1 HP Single Impeller Centrifugal Pump CM 32 - 1980 GPH - 110V/220V - 1PH) for the separation process. The hydrocyclone was opened at the bottom allowing the glycerin at the bottom to run off after which the biodiesel was collected through the overflow section and stored. This process is continued with variation in the speed of the centrifugal pump using a variable frequency drive, which consists of an alternating current (AC) motor and a variable frequency controller (VFC). As the speed of the centrifugal pump is varied, the corresponding pressure is also noted for evaluation purpose. Readings were taken throughout the process and the time used for each turn of separation viz a viz the speed was also noted for efficiency evaluation of the hydrocyclone.

### 3.2 Effect of acid concentration on cyclone collection efficiency

Effect of acid concentration was investigated in the testing of the developed hydrocyclone to detect the efficiency of the hydrocyclone. Variation in the density and viscosity of biodiesel and glycerol in relation to the proportion of chemical mixture was firstly evaluated and analyzed. Two different experiments were carried out with respect to addition of sulphuric acid. In the first experimental run, 3.0 liters of methanol (20 % of PKO) was measured and poured into the beaker, with 135.0 g of NaOH pellet which was allowed to completely dissolve in the methanol was allowed to react with 15 liters of PKO pre-heated to temperature between 60 and 55 °C for 40 minutes before allowed to pass through the hydrocyclone for the separation of biodiesel and glycerol.

The second experimental run was carried out with same amount of Methanol and NaOH but the PKO was mixed with 1.87 liters of Sulphuric acid (ratio of PKO to acid = 8:1) before pre-heating to 60 °C and mixed with methanol and NaOH mixture. After the two experimental runs, it was deduced that the amount of

biodiesel discovered when sulphuric acid was added was higher than that with no addition of sulphuric acid. And this occur as a result of the chemical reaction that took place when sulphuric acid was added reducing the amount of PKO wasted as a result of saponification. These findings result is consistent with most of the previous studies of Zhang *et al.* [20], Xu *et al.* [21] and Tang *et al.* [22] when they investigated the effect of acid concentration, loading and viscosity on the collection efficiency of biodiesel and glycerol. The results of this experimental runs is tabulated in Tables 1 and 2.

Table 1: Results for the PKO separation experiment without sulphuric acid.

<b>Experimental conditions</b>	<b>1<sup>st</sup> Run</b>	<b>2<sup>nd</sup> Run</b>	<b>Average</b>
Reaction temperature (°C)	60.00	60.00	60.00
Reaction time (min)	40.00	40.00	40.00
PKO quantity (liters)	15.00	15.00	15.00
Methanol quantity (liters)	3.00	3.00	3.00
NaOH concentration (g)	135.00	135.00	135.00
Biodiesel obtained (liters)	6.85	6.97	6.91
Glycerol obtained (liters)	5.65	5.53	5.59
Losses (liters)	5.47	5.41	5.44
<b>Biodiesel yield (%)</b>	<b>38.15</b>	<b>38.72</b>	<b>38.49</b>

Table 2: Results for the PKO separation experiment with sulphuric acid.

<b>Experimental conditions</b>	<b>1<sup>st</sup> Run</b>	<b>2<sup>nd</sup> Run</b>	<b>Average</b>
Reaction temperature (°C)	60.00	60.00	60.00
Reaction time (min)	40.00	40.00	40.00
PKO quantity (liters)	15.00	15.00	15.00
Methanol quantity (liters)	3.00	3.00	3.00
NaOH concentration (g)	135.00	135.00	135.00
Sulphuric acid quantity (liters)	1.87	1.87	1.87
Biodiesel obtained (liters)	9.07	9.90	9.48
Glycerol obtained (liters)	5.30	4.40	4.85
Losses (liters)	4.42	4.46	4.44
<b>Biodiesel yield (%)</b>	<b>45.67</b>	<b>49.82</b>	<b>47.74</b>

### 3.3 Effect of inlet velocity on cyclone efficiency

For the experimental testing of the fabricated hydrocyclone, the inlet velocity of the pump was used to determine the effect on the efficiency of the machine as related to the discharge rate at the underflow and overflow section of the hydrocyclone. The variable frequency drive was utilized to control the speed of the pump so as to determine the effect on the discharge rate and cyclone efficiency as a whole. Two different pump pressures were utilized to determine the effect of inlet velocity on the cyclone efficiency. The

Pressure at inlet for the first run of experiment was fixed at 70 kPa and that of the second run was fixed at 80 kPa. It was recorded that at constant temperature of 60 °C as the pressure rate increases, there is a corresponding increase in the discharge rate at the underflow and overflow outlets. Stopwatch was used to determine the suction rate and discharge rate. It was established that for experimental run of 70 kPa, 15 liters of PKO, 2.04 minutes was used to suck and separate the PKO and 1.67 minutes was used to separate that of 80 kPa. It was also noticed that the separation efficiency was higher during the experimental run with the higher pressure due to increase in swirling force created as a result of high pressure from the pump similar results was recorded by Oriaku *et al.* [23], Jing-Xuan *et al.* [24] and Lianjun *et al.* [25] when they carried out effects of inlet velocity on cyclone collection efficiency for different hydrocyclones designed. Figure 3 shows the picture of the separated glycerol and biodiesel in one of the experimental runs.



Figure 3: Glycerol and Biodiesel in container after separating process.

#### 4. CONCLUSION

This research work at completion developed a hydrocyclone for production of biodiesels from palm kernel oil. The experiment gave a percentage conversion of palm kernel oil to biodiesel as 80%. The research also established the effect of applying the use of hydrocyclone in the separation of biodiesel as it is more time efficient compared with using decantation as a mode of separation. Furthermore it has established the effect of velocity variation and acid addition over the machine efficiency and also the yield of biodiesel.

#### References

- [1] IEA International Energy Agency (2017). World Energy Outlook 2017, IEA, Paris. <https://www.iea.org/reports/world-energy-outlook-2017>, License: CC BY 4.0.
- [2] IEA International Energy Agency (2021). Key World Energy Statistics 2021. IEA Publications, Paris 1-81.
- [3] Marek, W, Lakhbir, S. B. and Grzegorz, L. (2021). Effect of the central rod dimensions on the performance of cyclone separators - optimization study, *Separation and Purification Technology*, 274:1-21.
- [4] Petrovsky, E. A., Bashmur, K. A., Kolenchukov, O. A., Kachaeva, V. A. and Sinitskaya, A. Ye. (2021). Experimental testing of the effectiveness of novel hydrocyclones for separation of impurities in biofuels. *Journal of Physics: Conference Series*. 2094(052045): 1-6.
- [5] Mizik, T. and Gyarmati, G. (2021). Economic and Sustainability of Biodiesel Production—A Systematic Literature Review. *Clean Technology*. 3:19–36. <https://doi.org/10.3390/cleantechnol3010002>
- [6] Bockey, D. (2019). The significance and perspective of biodiesel production – A European and global view. *Oilseeds & fats Crops and Lipids*. 26(40): 1-8.
- [7] Qian, F., Huang, Z., Chen, G. and Zhang, M. (2006). Numerical study of the separation characteristics in a cyclone of different inlet particle concentrations. *Computers and chemical engineering*, 31: 1111-1122.
- [8] He, M., Zhang, Y., Ma, L., Wang, H., Fu, P. and Zhao, Z. (2018). Study on flow field characteristics in a reverse rotation cyclone with PIV, *Chemical Engineering and Processing*, 126:100–107.
- [9] Li, S., Li, R. N., Nicolleau, F. C. G. A., Wang, Z. C., Yan, Y. J., Xu, Y. and Chen, X. (2020). Study on oil–water two phase flow characteristics of the hydrocyclone under periodic excitation. *Chemical Engineering Research and Design*. 159: 215–224.
- [10] Zhang, Y., Ge, J., Jiang, L., Wang, H. and Duan, Y. (2022). Effect of Internal Vortex-Finder on Classification Performance for Double Vortex-Finder Hydrocyclone. *Separations*, 9(88): 1-15.
- [11] Bibek, A., Printhivi, G., Rakish, S. and Aman, K. (2019). Design, Fabrication and Testing Of Hydrocyclone Separator as Sediment Separation System. *KEC Conference Proceedings*. 7-11.
- [12] Colman, D. A. and Thew, M. T. (1983). Correlation of separation results from light dispersion hydrocyclones. *Chemical Engineering Research and Design*. 61:233–240.
- [13] Gomez, C. Caldentey, J. and Wang, S. (2001). Oil-Water Separation in Liquid-Liquid Hydrocyclones (LLHC) – Experiment and Modeling, *SPE Annual Technical Conference and Exhibition. 2001, New Orleans, Louisiana, Sep 30-Oct 3, 2001, Paper No. SPE 71583*.
- [14] Motsamai, O. S. (2010). Investigation of the Influence of Hydrocyclone Geometric and Flow Parameters on Its Performance Using CFD. *Advances in Mechanical Engineering*. Article 593689:1-12.
- [15] Praveen, G. D. A. G. (2011). Study on design and performance evaluation of hydrocyclone separator for micro irrigation system. *International Journal of Agricultural Engineering*, 4(2): 200-205.

- [16] Elsayed, K. and Lacor, C. (2014). Analysis and Optimisation of Cyclone Separators Geometry Using RANS and LES Methodologies. In: Deville, M., Estivalezes, J. L., Gleize, V., Lê, T. H., Terracol, M., Vincent, S. (eds) *Turbulence and Interactions. Notes on Numerical Fluid Mechanics and Multidisciplinary Design*, Springer, Berlin, Heidelberg. 125: 65-75.
- [17] Wang, W., Yu, J., Zheng, X., Lu, X. and Lin, W. (2017). A New Method for Predicting the Hydrocyclone Efficiency with the Light Dispersed Phase. *Energy Procedia* 105: 4428 – 4435.
- [18] Ojolo, S. J., Adelaja, A. O. and Sobamowo, G. M. (2012). Production of Bio-Diesel from Palm Kernel Oil and Groundnut Oil. *Advanced Materials Research*. 367:501-506.
- [19] Eze, S. O., Ngadi, M. O., Alakali, J. S. and Odinaka, C. J. (2013). Quality Assessment of Biodiesel Produced From After Fry Waste Palm Kernel Oil (PKO). *European Journal of Natural and Applied Sciences*. 1(1):38-46.
- [21] Xu, Y., Tang, B., Song, X. and Yu, J. (2019). A high-efficiency hydrocyclone designed by response surface methodology for acid hydrolysis residue recycling. *Royal Society Open Science* 6(1): 172339.
- [20] Zhang, Y., Cai, P., Jiang, F., Dong, K., Jiang, Y. and Wang, B. (2017). Understanding the separation of particles in a hydrocyclone by force analysis. *Powder Technology*, 322: 471-489.
- [22] Tang, Z., Yu, L., Wang, F., Li, N., Chang, L. and Cui, N. (2019). Effect of particle size and shape on separation in a hydrocyclone. *Water*. 11(1):16.
- [23] Oriaku, E. C., Agulanna C. N., Edeh C. J. and Adiele I. D. (2014). Correlation Between Entry Velocity, Pressure Drop And Collection Efficiency In A Designed Stairmands Cyclone. *American Journal of Engineering Research*. 03(06):120-126.
- [24] Jing-Xuan, Y., Guo-Gang, S., Yu-Ming, Z., Qiang, M. and Chuan L. (2017). The Effect of Inlet Velocity on the Performance of Oil Shale Ash Cyclone Separator. *Oil Shale* 34(2):155–166.
- [25] Lianjun, C, Hui, M., Zhenjiao, S., Guanguo, M., Pengcheng, L., Chunkui, L. and Xiaochun, C. (2022). Effect of inlet periodic velocity on the performance of standard cyclone separators. *Powder Technology*. 402: 117347.