

# DESIGN, FABRICATION AND PERFORMANCE EVALUATION OF A SINGLE SCREW EXTRUDER FOR THE PRODUCTION OF FLOATING FISH FEED

## Original Research Article

---

**Abstract:** An extruding machine for the production of floating fish feed was designed and fabricated. Performance evaluation of the fabricated floating fish feed extruding machine was done. The design of the hopper, shaft, barrel, screw and die of the machine were done using standard equations. Effect of extrusion parameters which are moisture content (20% 25%, 30%, 35%, and 40%) die size (2mm, 4mm, 6mm, 8mm and 10mm) and screw speed (150 rpm, 200 rpm, 250rpm, 300rpm and 350rpm) on expansion ratio, floatability, specific mechanical energy and efficiency were evaluated. The result shows that moisture content has significant effect on all the variables, as highest expansion ratio of 32% was obtained at 30% moisture content and 6mm die size. Highest feed floatability was 97% at 30% moisture content and 6mm die size. The highest specific mechanical energy of the machine was 30kJ/kg at 40% moisture content and 4mm die size. Die size variation also shows high impact on the machine performance, showing highest efficiency of 83% at 10mm die size and 250 rpm while the floatation rate was 98% at 6mm die size. Screw speed has significant effect on efficiency having the highest as 85% at 150rpm and floatability of 93% at 150rpm while the specific mechanical energy of 29kJ/kg was the highest at 350rpm. Operation condition was at its best at 30% moisture content, 6mm die size and 150 rpm of screw speed. The feed moisture content, machine die size and screw speed have significant effect on the performance of the machine. Careful selection and combination of these factors will give optimum performance of the machine during extrusion of resin.

---

**Keywords:** extrusion, floating fish feed, expansion, Screw Speed, die size

## 1.0 INTRODUCTION

Extrusion technology has been on the rise for decades, it was initially known in the plastic industry and the metallurgical industry. Today; agro processing and food processing industry have inculcated the use of extrusion cooking technology in their processing system (Moscicki, 2011). Food extruders or extrusion cookers are known to have high temperature and pressure with low retention time cooking technique i.e. HTST - high temperature short time equipment (Moscicki, 1984, Idowu *et al.*, 2019, Olaoye *et al.*, 2022). Extruders have been placed under two types which are single screw extruder SSE and twin-screw extruder TSE (self-cleaning extruder) according to Leszek (2011). The single screw extruder is attributed to high temperature generated as a result of frictional force, between the screw and the barrel and the heating element in the barrel. Fundamentally; extrude that are of cereal based e.g. fish feed composite are easily extruded directly into different shapes and sizes with the use of die in different shapes and sizes (Moscicki, 1984).

Demand for aquaculture produce for human consumption has been on the rise in the past decades which as necessities, the need to improvise quick method of feeding for fishes, in which pelleting the feed will be of good advantage, most fish feed in America are in pellet to improve the quality of aquaculture. Anon(1991). On the other hand, pelleted feeds produce from pelletizer cannot give the expected quality of feed. Feed produced by pelletizer will sink immediately on water; while that of extruder will surly float on water as a result of gelatinization during processing - for aquaculture to consume it conveniently. According to Behnke (2001), floating fish feed from extruder is considered better than sinking feeds because of it physical and nutritional benefits. Its physical benefits ranges from, ease of handling by man and aquacultures, improved surface attractiveness, reduction in percentage of food waste; while its nutritional

benefits are good digestibility and high conversion rate. Extrusion machine is a good device in the agro-process industry, for its ability to produce feeds faster and improve the nutritional value of the feed. Its performance being dependent of its geometry (shape and size); control of product quality, improved digestibility and more extensive performance (Karaj and Müller, 2011). Extruder component contain several static and kinematic parts for the objectives of its fabrication to be achieved. Static components of the machine are hopper; barrel, die, cooling jacket and head etc. while the kinematic components are motor shaft; chain, sprocket, screw conveyor and cutting device. Also, it contains a feeding system to regulate the feeding rate. The objective of this research work is to design, fabricate and evaluate a floating fish feed extruder.

## 2. Materials and Methods

### 2.1 Material Selection and Production Planning

In the table below are the summary of the design prerequisites and materials used in the fabrication of the machine component. All materials were sourced locally after which examination was conducted on each of the component, to locate point and position they will occupy. The below information was used to carry out production plane and later assembly plane. Electrodes; hammer, block, sniper, welding machine, cutting machine, grinding machine, drilling machine, hack saw, vise and lathe machine, are the machine tools and equipment used in fabrication and construction of this machine.

**Table 1** List of component parts of the machine

Component parts	Dimension	Material used	Quantity
Hopper	$\Phi 300 \times 435\text{mm}$	Mild steel plate	1
Barrel	$\Phi 166 \times 800\text{mm}$	Stainless steel (aco pipe)	1
Feeder barrel	$\Phi 55 \times 266\text{mm}$	Stainless steel (aco pipe)	1
Screw conveyor	$\Phi 136 \times 1000\text{mm}$ (inner shaft), $\Phi 20 \times 750\text{mm}$ (sleeve pipe)	Stainless steel	1

Feeder screw conveyor	$\Phi 45 \times 333\text{mm}$ (inner pipe) $\Phi 5 \times 250\text{mm}$ (sleeve pipe)	Stainless steel	1	
Die head plate	$\Phi 172 \times 20\text{mm}$	Stainless steel	1	
Frame	$4\text{mm} \times 4\text{mm}$	Angle iron 6		
Sprocket	$\Phi 350\text{mm}$	Mild steel	1	
Fasteners (bolt and nut)	$\Phi 15 \times 50\text{mm}$	Mild steel bold		20
	$\Phi 20 \times 50\text{mm}$ (for barrel casing)	Nut	6	
Pillow bearing	$\Phi 60$	-	2	
Flat bar	$\Phi 40\text{mm} \times 80\text{mm}$	Mild steel	1	
Stainless steel welding	Gauge 10 and 12	Stainless steel		2packets
Mild steel welding	Mild steel		2	
Electrode		-		2
Grinding disk	-	-		4
Electric motor	22 horse power	-		1
Feeder electric motor	2	-	1	
Chain	30mm thickness	-		1

## 2.2 Machine Design

The design of this machine was done by putting into consideration of all mathematical constraints being the dependent of engineering principles, inclusion of cost analysis and consideration of couple with accessibility, ease of operation, stress and strain, durability, works and efficiency. The design of this machine was divided into two sections:

(1) **Design of the static components:** this involves the principles governing each component parts and mathematical calculations on the factors that may affect the design. These parts are, barrel, die, hopper, head and frame.

(2) **Design of kinematic component:** This encompasses component like chain and sprocket unit, motor and screw conveyor design.

(3) **Design Analysis:** Hopper was designed with the intertwine of two shapes, for easy flow of feed materials be it granular or fine particle. This consists of a frustum of a pyramid and a cub, with their mathematical proven below.

Volume of the hopper = volume of a frustum of a pyramid + volume of a cub

$$V_1 = \frac{1}{3}h(B_1 + B_2 + \sqrt{B_1B_2}) \quad (1)$$

$$V_2 = L \times B \times H$$

$$(2)V_3 = \frac{1}{3}h(B_1 + B_2 + \sqrt{B_1B_2}) + L \times B \times H$$

(3)Where

$V_1$  is the volume of the frustum of pyramid  $\text{cm}^3$ ,

$V_2$  is the volume of the cub,

$V_3$  is the volume of the hopper,

$h$  is the height of the frustum,

$B_1$  is the area of the top of the frustum,

$B_2$  is the area of base of the frustum,

$L$  is the length of the cub,

$B$  is the breath of the cub,

$H$  is the height of the cub,

**T is the** Thickness of the hopper

$$T = r_1 - r_2 \quad (4)$$

$$\text{Since; } \textit{density} = \frac{\textit{mass}}{\textit{volume}}$$

Mass of hopper = density of mild steel  $\times$  volume of the hopper

$$M = \rho \times V \quad (5)$$

Weight of the hopper = mass of the hopper × Acceleration due to gravity.

$$W = m \times g \quad (6)$$

The flow factor  $f$  can be determined with the use of known factors that determine the flow factor, angle  $\Theta$ , wall friction, internal friction and the semi included angel of the metal.

$$W = H(\theta) \frac{CAS}{\rho^0 g / g_c} \quad (7)$$

$$H(\theta) = 1 + \frac{\theta}{180} \quad (8)$$

Coefficient of friction between the surface of the hopper and the feed materials is expressed in terms of angle of phase  $\theta$  that is

$$\theta = Tan^{-1}(\mu) \quad (9)$$

$\Delta y$  and  $\Delta x$  are effective angle internal friction rise and run respectively.

$$\mu = \frac{\Delta y}{\Delta x} \quad (10)$$

$$= \frac{1.0}{1.73} = 0.578$$

$$\theta = tan^{-1}(0.578)$$

$$\theta = 30^\circ$$

To get the wall friction angle from the rise and run chart of (George, 1996)

$$tan\sigma_\omega = \frac{\Delta y}{\Delta x} = \frac{1.03}{3.0} = 0.343$$

$$\sigma_\omega = tan^{-1}(0.3433)$$

$$\sigma_{\omega=19^{\circ}}$$

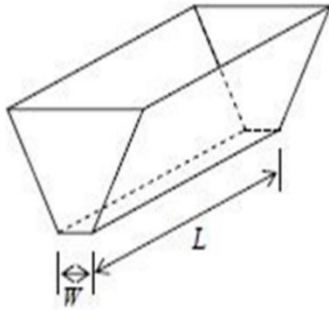

The semi included angle =  $28^{\circ}$   $H = 2.47$  and the flow factor  $ff = 1,84$  was obtained from (George, 1996)

$$w = 2.47 \frac{(0.83)(1) 1000}{1800 \times 9.81}$$

$$w = \frac{2.47 \times 0.83 \times 1 \times 1000}{1800 \times 9.81}$$

$$w = 0.1161$$

The minimum width of the symmetrical slot outlet hopper is 0.1161 ( $W \times L$ )

### 2.2.1 Determining mass flow rate of the symmetrical hopper

The discharge rate of the symmetrical hopper was obtained by the use of Jenike, (1964) equation.

$$M = \rho^{\circ} A \sqrt{\frac{Bg}{2(1+m)\tan(\theta)}} \quad (11)$$

Where:

$\theta$  is semi included angle of the hopper ( $^{\circ}$ )

$m$  is discharge rate (Kg/ sec)

$\rho^{\circ}$  is the bulk density (kg/m<sup>3</sup>)

g is gravity acceleration ( $9.807\text{ms}^{-2}$ )

B is  $w(m)$ ,  $m = 0$  in symmetric hopper

Area  $A = \text{width } W \times \text{Length } L$

$$A = WL(m^2) \quad (12)$$

The stress acting on the hopper is given in the assumption below by Jassen (1985)

$$P_v = \frac{\rho \cdot gW}{4\mu k g_c} \left(1 - \exp\left(-\frac{4\mu kz}{D}\right)\right) \quad (13)$$

g is the gravity constant to convert conversion factor and w is the maximum width of the hopper.

$$P_w = kp_v \quad (14)$$

### 2.2.2 Capacity design for a given electric motor rating

The electric motor selected is able to start the machine and run it effectively while fully loaded.

From,

$$\text{power} = \frac{\text{workdone}}{\text{time}}$$

$$\text{workdone} = \text{force } f \times \text{distance } d$$

$$\text{power} = \frac{\text{force } f \times \text{distanc } d}{\text{time } t}$$

$$\text{power } P = \frac{f \times d}{t}$$

$$P = F \times V \quad (15)$$

Where:

P is power in watts,

F is rotational force acting on the shaft in newton (N)

V is linear velocity of the electric motor shaft ( $\text{ms}^{-1}$ )

Recall,

$$F = ma \quad (16)$$

M is mass of rotating shaft(kg)

a is angular acceleration of the shaft part( $\text{rad/s}^{-2}$ )

$$a = w^2r \quad (17)$$

W is angular velocity of the motor( $\text{rad/s}$ ),

$$w = \frac{v}{r}$$

$$v = rw \quad (18)$$

Therefore, Force becomes

$$F = mw^2r \quad (19)$$

And power becomes

$$P = Mw^2r \times \omega r \quad (20)$$

$$W = \frac{2\pi N}{60} \quad (21)$$

$$P = M \left(\frac{\pi N}{60}\right)^3 r^2 \quad (22)$$

### 2.2.3 Design of screw conveyor diameter and power to drive conveyor

The diameter and power of the screw conveyor needed for material conveying at a flow rate of 3kg/min. for capacity of segmented screw conveyor was calculated from the use of Spirakorsky and Dyachkov, (1966)

$$D^2 = \frac{4Q}{60\pi S n \Phi \rho c} \quad (23)$$

Where;

Q is capacity of screw conveyor

S is the screw pitch

n is speed of conveyor-loading efficiency

p is free bulk density of the material

c is loading factor depending on the inclined angle to the horizontal for slow flowing abrasive material it was recommended that  $S = 0.8D$ ,  $\varphi = 0.125$ ,  $C = 1$  our recommended minimum and maximum speed of conveyor is between 50 – 500rpm.

$$D^2 = \left( \frac{2000}{60 \times 3.142 \times 0.8D \times 120 \times 0.125 \times 1800 \times 1} \right)$$

$$D = \left( \frac{2000}{4072032} \right) 0.3$$

$$D = 0.101m$$

Hence; our screw conveyor diameter is 0.101m

$$P_r = \frac{QL}{367} (\omega o + \sin \beta^\circ) \quad (24)$$

Where  $\omega$  is 4.0 for slow abrasive material, inclination angle of conveyor ( $\beta^\circ$ ) is  $0^\circ$

L = length of conveyor.

$$P_r = \frac{130000 \times 1}{367} (4 + 0) = 1.416 \text{kw}$$

#### 2.2.4 Design of pitch and pitch circle diameter

The design of pitch diameter was done with the use of this equation

$$P = D \sin\left(\frac{\theta}{2}\right) \quad (25)$$

We know that  $\theta = \frac{360^\circ}{T}$

$$P = D \sin \frac{180^\circ}{T} \quad (26)$$

$$P = 0.10 \sin 20$$

$$P = 0.0342 \text{m}$$

$$D_o = D + 0.8d_1 \quad (27)$$

$D_o$  is outside diameter of the sprocket(m)

D is diameter of the pitch circle

T is number of teeth on the sprocket

$d_1$  is diameter of the chain roller

$$D_o = 0.10 + 0.8 \times 0.015$$

$$D_o = 0.10 + 0.012$$

$$D_0 = 0.112m$$

### 2.2.5 Determining the velocity ratio of the chain drive

The velocity ratio of the chain was determining with the use of this equation

$$V.R = \frac{N_1}{N_2} = \frac{T_2}{T_1} \quad (28)$$

Where;

$N_1$  is the speed of rotation of smaller sprocket in rpm

$N_2$  is speed of rotation of lager sprocket in rpm

$T_1$  is number of teeth in the smaller sprocket

$T_2$  is number of teeth on the larger sprocket.

### 2.2.6 Determination of chain length and its center distance.

The length of the chain was calculated from the use of this equation;

$$L = K.P \quad (29)$$

$$K = \frac{T_1+T_2}{2} + \frac{2X}{P} + \left[\frac{T_1+T_2}{2\pi}\right]^2 \frac{P}{X} \quad (30)$$

$$K = \frac{9+14}{2} + \frac{2 \times 0.9}{0.034} + \left[\frac{14-9}{2 \times 3.142}\right]^2 \frac{0.034}{0.9}$$

$$K = 64$$

Therefore; the length of the chain is

$$L = K.P$$

$$L = 64 \times 0.034 = 2.19 = 2.2m$$

### 2.2.7 Determination of the center distance

The center distance between the center distance  $x$  was calculated with the use of this equation Spivakovsky, (1967).

$$k = \frac{p}{4} \left[ K - \frac{T_1 + T_2}{2} + \sqrt{\left[ \left( K - \frac{T_1 + T_2}{2} \right)^2 - 8 \left( \frac{T_1 - T_2}{2\pi} \right)^2 \right]} \right] \quad (31)$$

$$X = \frac{0.0342}{4} \left[ 64 - \frac{9 + 14}{2} + \sqrt{\left( 64 - \frac{9 + 14}{2} \right)^2 - 8 \left( \frac{14 - 9}{2 \times 3.142} \right)^2} \right]$$

$$X = 0.83m$$

### 2.2.8 Determination of power transmission in chain

Power transmitted by chain was derived from Jenike (1964) equation

$$P = \frac{W_B \times v}{n \times K_s} \quad (32)$$

Where;

$W_b$  is breaking load in newton's,

$V$  is velocity of chain in m/s

$n$  is factor of safety

$k_s$  is service factor

## 2.3 Performance Evaluation of the Machine

**Specific Mechanical Energy(SME):** the amount of energy generated from the machine and being converted to heat energy that transform the extrude – the work done by the machine on the extruder which also called specific mechanical energy of the machine.

$$SME = \frac{2\pi \times \tau \times \frac{S_s}{60}}{F_r} \times 3.6(kj/kg) \quad (33)$$

Where;

$\tau$  is the torque(Nm)

$S_s$  is screw speed (rpm)

$F_r$  is feed rate(kg/h)

Calculation of machine torque was done with the use of this equation.

$$\tau = \frac{60p}{2\pi N} \quad (34)$$

$$MC = \frac{M_e}{T} \quad (35)$$

$$\dot{\eta} = \frac{M_e}{M_i} \quad (36)$$

The efficiency of the machine was determined with the use of this mathematical equation.

Efficiency of the machine( $\dot{\eta}$ ) in (%) was done by determining the capacity of the machine(MC) in (kg/min),  $M_e$  the mean mass of the extrude in (kg),  $T$  is the mean retention time(min) and  $M_i$  is the mean initial mass of the resin.

## 2.4 Evaluation Parameters

The evaluation of the machine was performed in a factorial design which consist of moisture content, die size and screw speed each at five different level. The different levels of

moisture content are 20,25,30,35 and 40%, while the different levels of die sizes are 2, 4, 6, 8 and 10mm and screw speed are 150, 200, 250, 300 and 350rpm respectively. This is the experimental procedure that was used to determine the effect of these extrusion factors on these extrusion variables that are considered: expansion ratio, floatability, specific mechanical energy and machine efficiency.

## **2.5 Preparation of Samples**

Soybean crud was use to replace ground nut cake(GNC) in order to improve it level of compatibility and reduce the percentage of oil in the fish feed. Other components are sourced from farm support Nigeria limited along Ilesa Owo road Akure. The grinding was done in farm support factory, to increase the rate of compatibility of the resin during extrusion process, by reducing the surface area of the component. Mixing of the component was done mechanically for uniform and appropriate mixing of the composition before, during and after extrusion.

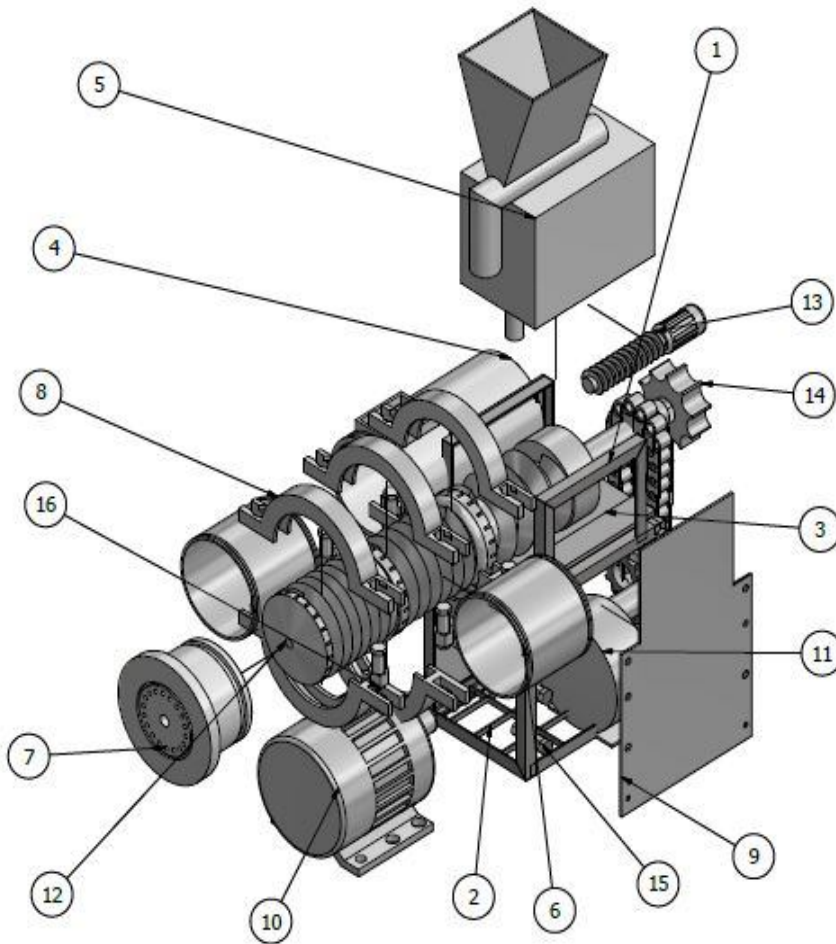
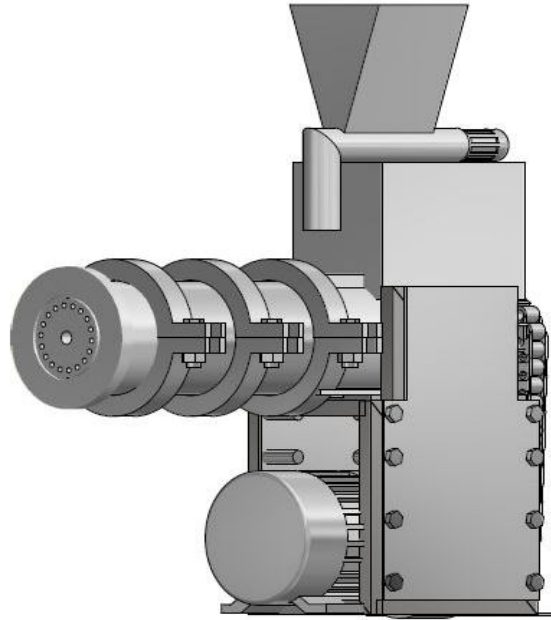

PARTS LIST			
ITEM	QTY	PART NUMBER	DESCRIPTION
1	1652.4	AISC - L 2 x 2 x 00 mm	Angle Steel
2	2100.0	AISC - 1/4x13/16 - 27.559	Flat Bar Steel
3	1	Plate 2	
4	1	Barrel 1	
5	1	Feeder	
6	2	Barrel 2	
7	1	Die	
8	6	Extruder Clip	
9	2	Plate 1	
10	1	Motor	
11	1	Gear	
12	1	Screw	
13	1	Feeder Scerw	
14	1	Sprocket	
15	22	Bolt 1	
16	6	Extruder Nut	

**Figure. 1** Extrusion machine and its exploded view

**Table 2 Ingredient Composition in Percentage**

Feed ingredients	percentage (%)
Maize	14
Soybean residue	30
Starch	10
Wheat bran	25
Soybean meal	10
Fish meal	10
Vitamin C	0.3
Methionine	0.4
Antioxidant	0.3

### 3.0 Results and Discussion

#### 3.1 Effect of Moisture Content on Expansion Ratio, Floatability, Specific Mechanical Energy and Efficiency of the Machine

Expansion ratio is the rate at which the extrude expanded in relative to the die size, varying the level of the moisture content and die size while the screw speed is kept constant. Moisture content of the resin played important role in the rate at which expansion takes place. The expansion ratio increased initially as the moisture content increases but later decreases with increase in moisture content. The highest rate of expansion was 32% which occurred at 30% moisture content and 6 mm die size; while the lowest was 18% at 40% moisture content, supported by Alam *et al.* (2016), Olaoye *et al.* (2022). The floatability of the extrude produced from the machine was affected by moisture content. It has significant effect on the floatability of the feed at 0.05 level of significant, while 97% highest floatability was recorded at 30% moisture content and the lowest at 40% moisture content of 66% value; this is in agreement with Khater *et al.* (2010) in their research on floatation. Specific mechanical energy was also significantly affected by moisture content; the lowest SME was obtained at 30% and the highest at 40% moisture content 17kJ/kg and 30kJ/kg respectively. This is in consonance with what Daood *et al.* (2007) observed in their research work. The highest efficiency of the machine is 87% which was

obtained at 30% moisture content and 6mm die size; while the lowest is 70% obtained at 40% moisture content. This is in-line with what Ojomo *et al.* (2010) came about in their research on palletization.

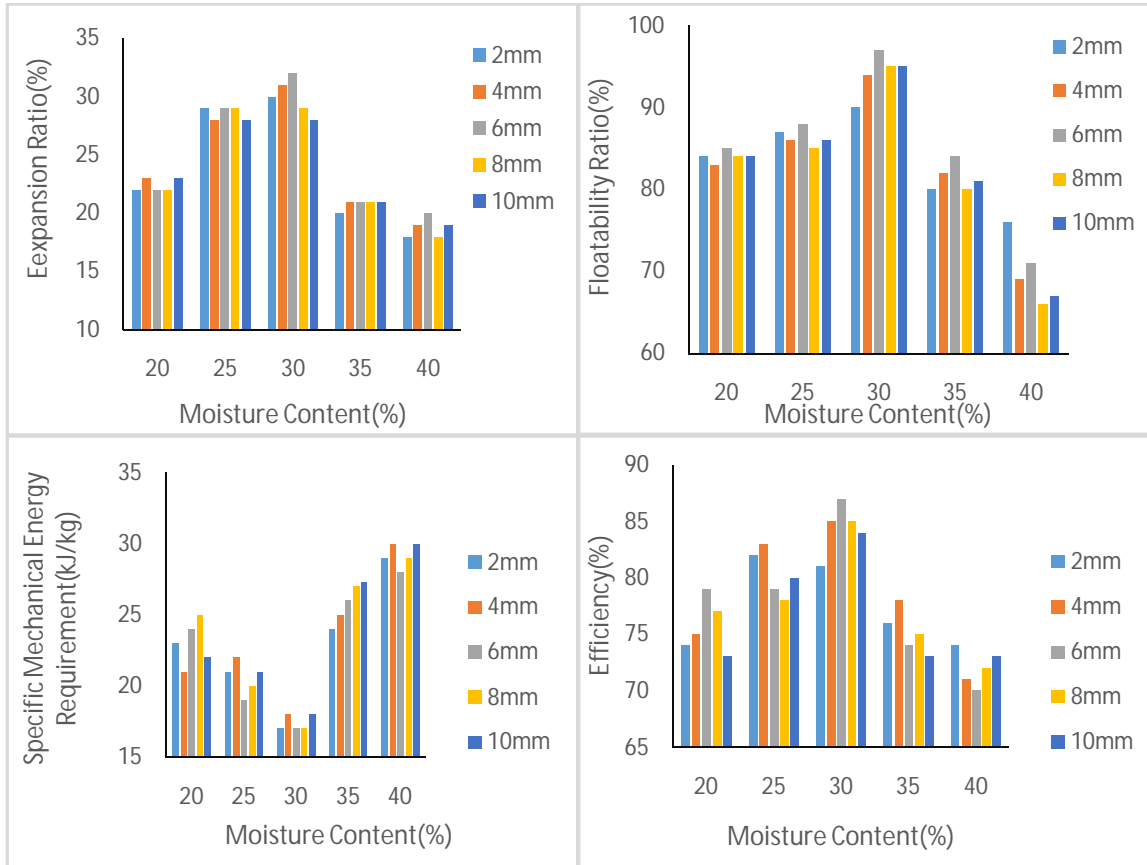

Figure 2 Graphical presentation of effect of moisture content on variables considered

### 3.2 Effect of Die Size on Expansion Ratio, Floatability, Specific Mechanical Energy Required and Efficiency

Expansion ratio of the resin was affected by the differences in die sizes as we varied the die sizes during our research work. The highest expansion ratio of 31% was recorded at 6mm die size while the lowest expansion ratio of 19% was obtained at 2mm die size; this is in similarity with the result of Abubakare *et al.* (2016). Likewise; the floatability ratio was at the zenith at 6mm die size of 98% while the lowest was at 10mm die size of 77% value, this is in line with Khater *et al.*

al. (2014). Specific mechanical energy consumption of 30kJ/kg was the highest at 2mm die size, while the lowest 17kJ/kg at 10mm die size Saheed *et al.* (2022) in their research work reported similar result. Efficiency of the machine increase as the die size increases from 2mm to 10 mm, this is in corroboration with what Ojo *et al.*, (2014) reported that the lowest efficiency was obtained at 2mm die size while the highest was recorded at 10mm die size.

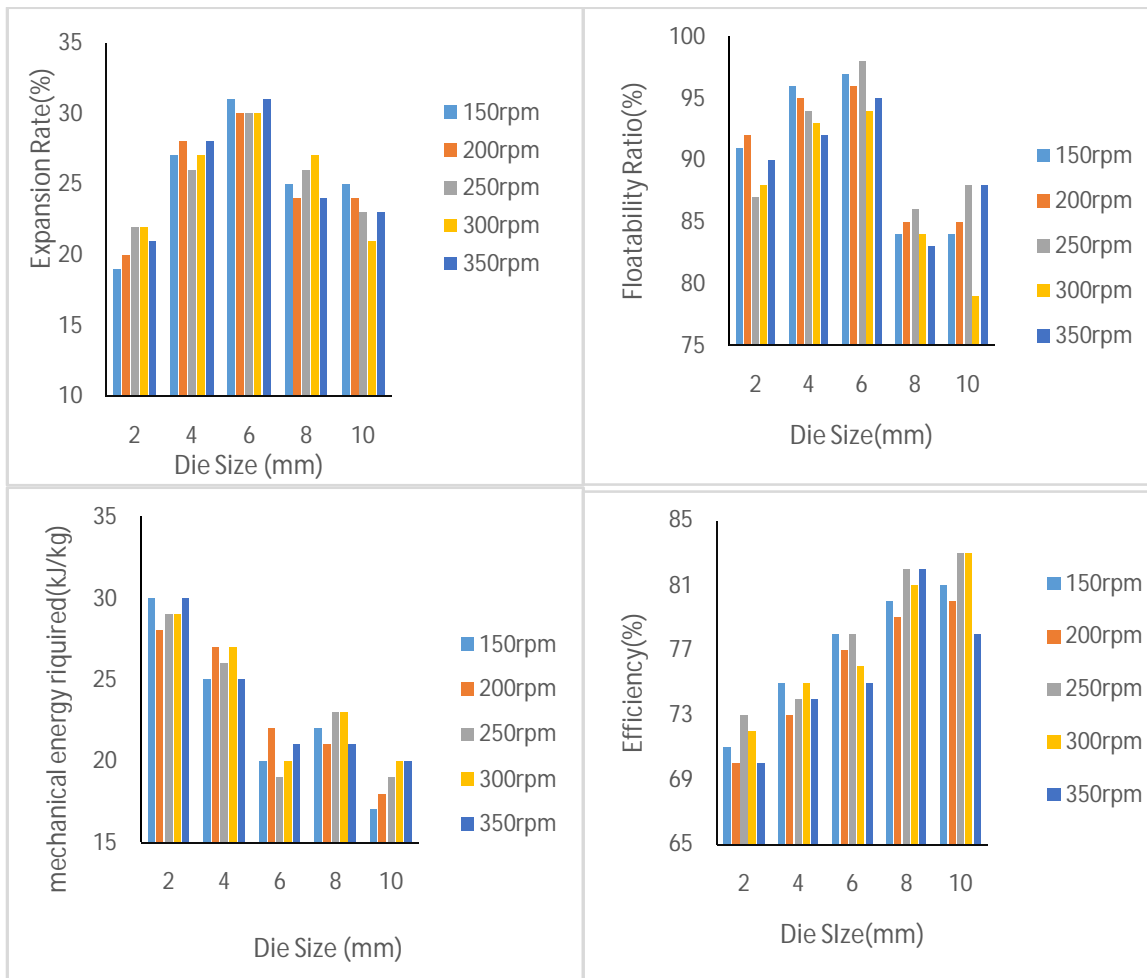

Figure 3 Graphical presentation of effect of die size on variables considered

### 3.3 Effect of Screw Speed on Expansion, Floatability, Specific Mechanical Energy Requirement and Efficiency

The variation in screw speed shows differences in responses on the variables considered. The expansion ratio does not show much difference at different level of screw speed. The highest expansion rate was observed at 150 rpm and 30% moisture content while the lowest was recorded at 250 rpm and 40% moisture content 32% and 20% respectively. Though; the effect of screw speed on expansion ratio was insignificant at 5% level of probability. Oduntan and Koya (2015) had similar result at screw speed less than 150 rpm. The highest floatability ratio of 93% was recorded at 150 rpm while the lowest floatability rate of 79% was observed at 300 rpm, Olaoye *et al.* (2022) also obtain a similar result. The specific mechanical energy 29kJ/kg was the maximum at 350 rpm which may be as a result of increase in torque required, this is in contrast with what stated by Folasayo and Zhongjie (2015) stated that energy consumption of single screw extruder has the lowest specific mechanical energy of 20kJ/kg was obtained at 250 rpm. Efficiency was at the highest point of 88% at 150 rpm while the lowest was 72% at 350 rpm. This result is similar to what Salawu *et al.* (2015) observed in their own research work. Idowu *et al.*, (2019) gave a consonance result in their experiment stating the significance of screw speed on the performance of fabricated decorticating machine.

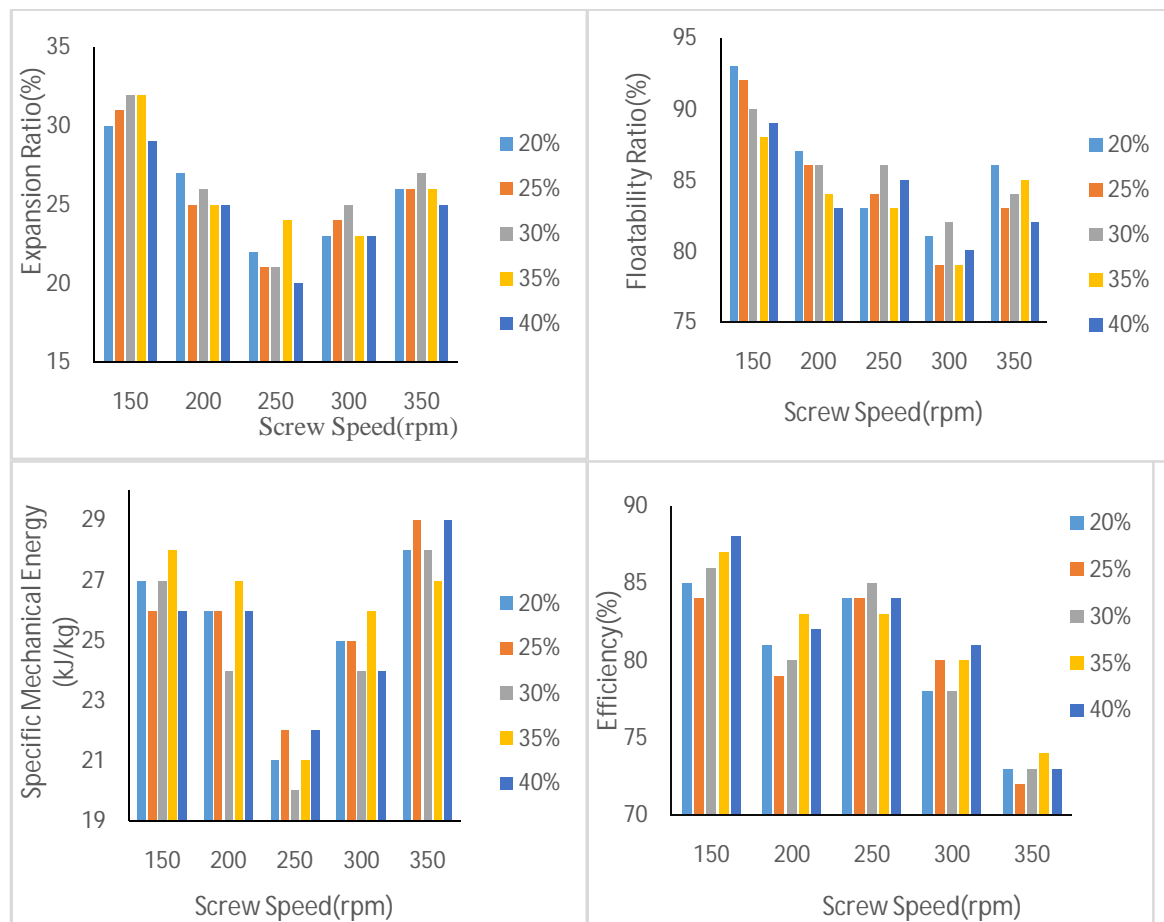

Figure 4 Graphical presentation of effect of screw speed on variables considered

#### 4.0 Conclusion

The design, fabrication and performance evaluation of the floating fish feed extruding machine was done. The result of the performance evaluation shows that moisture content has significant effect on expansion of which the highest value was at 30% moisture content and 6mm die size. Highest floatability was recorded at 30% moisture content and 6mm die size. Specific mechanical energy was at the lowest at 30% moisture content and die sizes 6, 8 and 10mm. The efficiency of the machine was best at 30% moisture content and 6mm die size. Die size has significant effect on expansion ratio according the result, 6mm die size is the most efficient die size on this machine, due to it optimization on the variables considered. Variation in screw speed

gave different response on the variable considered, resulted to an outcome that 150rpm was the best speed of operation for the machine.

## Reference

- Abubakar M. Y, Momoh A. T, and Ipinjolu JK. (2016) Effect of pelletizing machines on floatation and water stability of farm-made fish feeds, *International Journal of Fisheries and Aquatic Studies*. vol. 4 No. 3 pp.98-103.
- Alam, M. S., Kaur, J., Khaira, H., and Gupta, K. (2016). Extrusion and Extruded Products, *Food Science and Nutrition*, Vol. 56.pp 132-140.
- Anon, (1991). Feed Milling Equipment Developments. World Grain, *Sosland Publishing Company, WorosterPark, Surrey, England*. 9(8): 15-19.
- Behnke, K.C. (2001). Department of Grain Science and Industry, *Kansas State University, Manhattan, Kansas, USA, and was edited and published in FeedTech 2001 Vol 5 Nr 4*.
- Daood, V.M, Morad, M.; M.K. Afify, and U. Kaddour, (2007). Study on Some Engineering Parameters Affecting the Performance of Fish Feed Pelleting Machine. *Misr J.Ag.Eng.*, 24(2): 259-282.
- Folasayo, F. and Zhongjie, H., (2015).Energy Consumption and Efficiency in Single Screw Extrusion Processing of Selected Starchy Crops.*Journal of Natural Sciences Research*, vol. 5, no. 12, pp. 12-18.
- George, G. (2010) Chase, Hopper Design. *The University of Akron, solids notes*10, pp10-1-12.
- Idowu, D.O., S.A. Olaoye, E.O. Owolabi and Adebayo, J.M. (2019). Effect of Hydrothermal Pre-Treatment on Snake Gourd Seed Shelling. *International Journal of Current Microbiology and Applied Science*. Vol. 8, no. 2, pp. 1848-1858.
- Janssen, L.P.B.M., Noomen, G.H., and Smith, J.M. (1975) The temperature distribution across a single screw extruder channel. *Plast. Polym.*, 43, 135–140.
- Jenike, A.W (1964), Storage and Flow of Solids, *Utah Engineering Experiment Station, University of Utah, Salt Lake City, USA Bulletin No. 123* (Revised edition 1970)
- Karaj, S. and J. Müller, (2011). Optimizing mechanical oil extraction of *Jatropha curcas L. seeds with respect to press capacity, oil recovery and energy efficiency*. *Ind. Crops Prod.*, 34: 1010-1016.
- Khater, E.-S. G., Bahnasawy, A. H., and Ali, S. A. (2014). Physical and Mechanical Properties of Fish Feed Pellets. *Journal of Food Processing & Technology*, Vol. 5, pp.879-881.

- Leszek, M, and Dick J. (2011). *Extrusion-Cooking and Related Technique WILEY-VCH Verlag GmbH & Co. KGaA, Weinheim* ISBN: 978-3-527-32888-8.
- Moscicki, L., Mitrus, M., and Wojtowicz, A. (2011) *Technika ekstruzji w przetwórstwie rolnospożywczym* (in Polish), PWRiL, Warszawa.
- Moscicki, L.; Wojcik, S; Plaur, K.; van Zuilichem, D.J. (1984) *Extrusion cooking to improve the animal feed quality of broad beans*. *Journal of Food Engineering* vol. 3 issue 4. pp. 307-316.
- Oduntan, O., and Koya, O. (2015). Effect of speed, die sizes and moisture contents on resin. *Research of Agricultural Engineering*, Vol. 61, pp. 1262-1270.
- Ojo, S. T, Olukunle O. J, Aduewa T. O. and Ukwenya A. G. (2014) Performance Evaluation of Floating Fish Feed Extrude *Journal of Agriculture and Veterinary Science* Volume 7, Issue 12 Ver. pp 103-113.
- Ojomo, A. O., Agbetoye L. A. S. and Ologunagba F. O. (2010). Performance Evaluation of a Fish Feed Pelletizing Machine. *ARPN Journal of Engineering and Applied Sciences*, vol. 5, no. 9, pp. 88-97.
- Olaoye S. A, Owoseni O. T and Olalusi A. P. (2022). Optimization of Some Physical and Functional Properties of Extruded Soybean Crude Residue-Base Floating Fish Feed. *Turkish Journal of Agricultural Engineering Research (TURKAGER)*, vol. 3, no.1, pp. 31-50.
- Saheed A. O, Olanrewaju T. O., Olufunso O. O. (2022). Effect of Drying Temperature on the Proximate Composition of Soybean Crude Residue-Base Fish Feed. *International Journal of Food Science and Biotechnology*. Vol. 7, No. 2, pp. 40-47.
- Salawu, A.T. Isiaka, M. and Suleiman, L. (2015). Development of an Oil Extraction Machine for *Jatropha curcas* Seeds. *Journal of Scientific Research & Reports*, vol. 6, no. 4, pp. 313-328.
- Spivakovsky, A and Dyachkov. V (1966) *Conveyors and related equipment. Translated from the Russian by Don danemanis, peace publishers.*