

Graph Theoretic Technique to the Global Stability Analysis of the Discrete Age Structured SVEIR Model with Application to Ebola Virus Disease

1

Abstract

Discrete age structured models provide a better approach of discussing the spread of infectious diseases with infectivity, mortality and recovery being age dependent. Measures such as vaccination are carried out in discrete time or applied to individuals in certain age-groups. In the past Ebola Virus disease (EVD) outbreaks, infections in children under 5 years was associated with high mortality rates. In this work, a general discrete SVEIR epidemic model with age structure is formulated. The study establishes the existence of the endemic equilibrium and further shows that it is globally stable using the graph theoretic approach on the method of Lyapunov functions. The model is then applied to EVD dynamics to study the impact of vaccination on the age structured population. The numerical simulation of the discrete age case scenario demonstrates that vaccination of children under 5 years of age against EVD has a great impact in reducing their susceptibility because of the active immune system as compared to the older population who have a poor response to vaccine immunity. For the older population, vaccination is not very effective in reducing their susceptibility.

Keywords: Discrete, Age Structure

1 Introduction

Mathematical models are instrumental in providing guidance regarding the future projections of ongoing public health crises, and in assessing the potential impact various intervention strategies may have towards the transmission control. Age has been connected to symptom severity and mortality in several diseases like Ebola Virus Disease (EVD) and Corona virus (COVID-19) [6]. Age is also a clear modifier of survival probability, with very high values of case fatalities in young children and the elderly. An Ebola vaccines working group meeting of April 2019 recommended the vaccination of expectant women, lactating women and children below 5 years [12]. The report further suggested that manufacturers of candidate Ebola vaccines should prioritize the development of a strategy to generate safety, immunogenicity and efficacy data for children aged under 5 years [12].

Disease transmission models with age dependent contact rates are more realistic [2], which

makes the models with age dependent susceptibility relevant for vaccination planning [6]. Factors in an immunization program such as target groups and the number of doses recommended can be actualized easily in an age-structured framework. Age structure in disease models has been studied using continuous and discrete approaches in literature and they include ordinary differential equations for discrete age groups [4] and for continuous ages [9]. The challenge for ordinary differential equations models lies in the high dimensionality and scale of the system. This makes the establishment of the uniqueness and global stability of the endemic equilibrium when the effective reproduction number is greater than one very difficult. Discrete age structured models are regarded as nonlinear differential equations coupled on transmission networks.

With regard to transmission dynamics of a given infection there has to be interaction among the age groups and the subgroups and transition among the subgroups, which is analogous to the directed oriented paths in Graph Theory. A graph G can be drawn within age groups and between subgroups, because of the strong connectivity, which guarantees the existence of an oriented path. From a given age group, a unicyclic sub-graph can be formed by adding the infection arcs to the corresponding tree T which is equivalent to the total population N . Therefore the total number of infections can be considered as a sum over all the unicyclic graphs representing the interactions.

The study adapts a discrete age structured SVEIR epidemic model to analyze EVD data from the Democratic Republic of Congo and examine the effects of vaccination for children under 5 years. The paper is organized as follows; in section 2 the discrete age structured SVEIR model is developed and the effective reproduction number derived. In section 3, the global stability of the endemic equilibrium is discussed. In section 4, a model with three age groups is developed to analyze the impact of vaccination on the various age groups.

2 Description and Formulation of the Model

In this section, a general model is developed that subdivides the human population into classes of susceptible $S(t)$, vaccinated $V(t)$, exposed $E(t)$, infected $I(t)$ and recovered $R(t)$ with variations with respect to age. The susceptible population is recruited at the rate Λ and are vaccinated at the rate α and acquire infection at the rate β_{kj} , the vaccinated individuals acquire infection at the rate β'_{kj} upon interaction with the infected and recover at the rate θ , infected individuals die as a result of infection at the rate δ and recover at the rate π and natural death occurs in all classes at the rate μ . The total population is given by;

$$N(t) = S_k(t) + V_k(t) + E_k(t) + I_k(t) + R_k(t), k = 1, 2, \dots, n \quad (1)$$

The resulting model is represented by the flow diagram below;

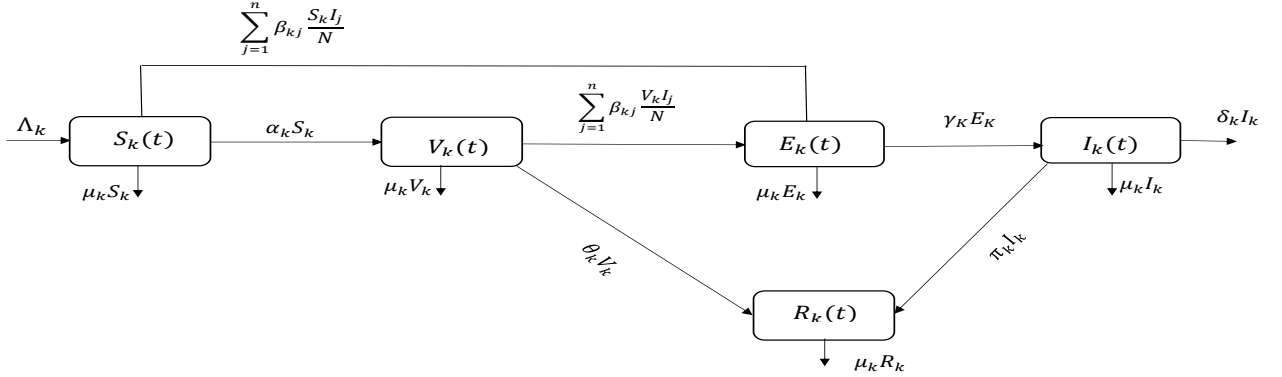

Figure 1: Discrete Age Structured Model flow diagram

The system of differential equations describing the dynamics of the model is as follows;

$$\begin{aligned}
 \frac{dS_k}{dt} &= \Lambda_k - \sum_{j=1}^n \beta_{kj} \frac{S_k I_j}{N} - (\mu_k + \alpha_k) S_k \\
 \frac{dV_k}{dt} &= \alpha_k S_k - \sum_{j=1}^n \beta'_{kj} \frac{V_k I_j}{N} - (\mu_k + \theta_k) V_k \\
 \frac{dE_k}{dt} &= \sum_{j=1}^n \beta_{kj} \frac{S_k I_j}{N} + \sum_{j=1}^n \beta'_{kj} \frac{V_k I_j}{N} - (\mu_k + \gamma_k) E_k \\
 \frac{dI_k}{dt} &= \gamma_k E_k - (\mu_k + \delta_k + \pi_k) I_k \\
 \frac{dR_k}{dt} &= \pi_k I_k + \theta_k V_k - \mu_k R_k
 \end{aligned} \tag{2}$$

$k = 1, 2, \dots, n$

and takes the initial condition;

$$S(t_0) = S(0), V(t_0) = V(0), E(t_0) = E(0), I(t_0) = I(0), R(t_0) = R(0); t_0 = 0$$

where S_k, V_k, E_k, I_k, R_k denote the k^{th} population segregated in terms of age that are susceptible, vaccinated, exposed, infected and recovered respectively.

3 Qualitative Analysis of the Model

3.1 Positivity and boundedness of Solutions

Since the model describes human population, the state variables of model (1) can be shown to be non-negative and ultimately bounded in $\Gamma(\mathbb{R}^5)$. Therefore, the model is

biologically meaningful and mathematically well posed.

3.2 The Effective Reproduction Ratio and Equilibrium

Definition 3.1. *The Effective reproduction number (R_v) is the average number of secondary infections due to a single infectious individual introduced in a fully susceptible population over the course of the infectious period in which vaccination is introduced as an intervention measure. If $R_v < 1$ it means that on average, an infected individual produces less than one new infected individual while $R_v > 1$ means each infected individual produces more than one new infection on average.*

R_v for model (2) is computed as the spectral radius of the next generation matrix [11] and is given by;

$$R_v = \left(\frac{\gamma_k(\beta_{kj}S_k + \beta'_{kj}V_k)}{N(\mu_k + \gamma_k)(\mu_k + \delta_k + \pi_k)} \right) \quad (3)$$

3.3 The Endemic Equilibrium \mathbf{E}^*

This is a state where the disease persists in a given population.

Proposition 3.1. *The endemic equilibrium $\mathbf{E}^*(S_k^*, V_k^*, E^*, I_k^*, R_k^*)$ of system (2) exists whenever $R_v > 1$.*

Proof. To prove the existence of the endemic equilibrium, it is shown that $\frac{dI}{dt} > 0$ whenever $R_v > 1$. From equation (4) of system (2);

$$\frac{dI_k}{dt} = \gamma_k E_k - (\mu_k + \delta_k + \pi_k) I_k \quad (4)$$

but from equation (3) of system (2),

$$E_k = \sum_{j=1}^n \frac{(\beta_{kj}S_k + \beta'_{kj}V_k)I_j}{N(\mu_k + \gamma_k)} \quad (5)$$

Therefore substituting for E_k equation (5) into equation (4) yields,

$$\frac{\gamma_k(\beta_{kj}S_k + \beta'_{kj}V_k)I_k}{N(\mu_k + \gamma_k)} - (\mu_k + \delta_k + \pi_k)I_k > 0 \quad (6)$$

Simplifying equation (6) using equation (3) gives;

$$(R_v - 1)I_k > 0 \quad (7)$$

□

Theoretically, if $R_v < 1$ the disease dies out and if $R_v > 1$, then the disease persists in a given population.

3.4 Global Stability of the Endemic Equilibrium

In this section results from [5] and [10] are reviewed to study the stability analysis of system (2).

Definition 3.2. Let $B = (\beta_{kj})_{n \times n}$ be a real matrix. If β_{kj} are non-negative for all k and j , then B is called a non-negative matrix. If B and $F = (f_{kj})_{n \times n}$ are both non-negative, then $B - F \geq 0$ if and only if $\beta_{kj} \geq f_{kj}$ for all k and j .

Definition 3.3. Let $B = (\beta_{kj})_{n \times n}$ be a non-negative matrix. If B satisfies one of the following properties, then B is called reducible.

(i) $n = 1$ and $B = 0$

(ii) $n \geq 2$, there exists a permutation matrix Q , such that; QBQ^T

$$\begin{pmatrix} B_1 & 0 \\ B_2 & B_3 \end{pmatrix}$$

where B_1 and B_3 are square matrices and Q^T is the transpose of matrix Q . Otherwise, B is called irreducible.

Consider the linear system $\bar{B}v = 0$, where;

$$\bar{B} = \begin{pmatrix} \sum_{l \neq 1} \bar{\beta}_{1l} & -\bar{\beta}_{21} & \dots & \dots & -\bar{\beta}_{n1} \\ -\bar{\beta}_{12} & \sum_{l \neq 2} \bar{\beta}_{2l} & \dots & \dots & -\bar{\beta}_{n2} \\ \vdots & \vdots & \vdots & \vdots & \vdots \\ \vdots & \vdots & \vdots & \vdots & \vdots \\ -\bar{\beta}_{n1} & -\bar{\beta}_{n2} & \dots & \dots & \sum_{l \neq n} \bar{\beta}_{nl} \end{pmatrix}$$

and $\bar{\beta}_{kj} \geq 0$. Let $L = G(B)$ be the laplacian matrix of the directed graph $G(B)$ associated to matrix B . The matrix $B = \beta_{kj}$ and $B^1 = \beta_{kj}^1$ codes patterns of interaction and transmission among groups that are built into the model. A directed graph $L = G(B)(G(B^1))$ whose vertex k represents the k^{th} group, $k=1,2,\dots,n$ associated to $B(B^1) = \beta_{kj}(\beta'_{kj})$ can be constructed with vertices $1,2,\dots,n$ and a directed arc (k,j) from k to j , if and only if $\beta_{kj}(\beta'_{kj}) > 0$. Since matrix $B(B^1)$ is irreducible then $G(B)(G(B^1))$ is strongly connected, this implies that any two distinct vertices are joined by an oriented path. Biologically, any two age groups k and j have an indirect or direct transmission route which is analogous to the oriented path.

Lemma 3.1. [1]

If B is non-negative and irreducible, then;

(1) The spectral radius $\rho(B)$ is a simple eigenvalue of B and B has a positive eigenvector $w = (w_1, w_2, \dots, w_n)$ corresponding to $\rho(B)$.

(2) If $B \leq F$, then $\rho(B) \leq \rho(F)$ and furthermore, if $B < F$ and $B + F$ is irreducible, then $\rho(B) < \rho(F)$.

(3) If F is a diagonal and positive matrix, then BF is irreducible.

Lemma 3.2. [3]

If matrix \overline{B} is irreducible and $n \geq 2$, then the following properties hold.

(1) The solution of the linear system $\overline{B}v = 0$ is the space of dimension 1, with a basis

$$\{(v_1, v_2, \dots, v_n)\} = \{(C_{11}, C_{22}, \dots, C_{nn})\}$$

where C_{ii} is the cofactor of the i^{th} diagonal entry of matrix \overline{B} , $i = 1, 2, \dots, n$.

(2) For all $1 \leq i \leq n$

$$C_{ii} = \sum_{T \in \mathcal{T}_i(k_j) \in E(T)} \prod \overline{\beta_{kj}}$$

and $C_{ii} > 0$ where \mathcal{T}_i is the set of all spanning subtrees of vertices of $G(B)$ that are rooted at vertex i and $E(T)$ is the set of all arcs of directed tree T .

Proof. See [3] for the proof. □

Proposition 3.2. Suppose $B = (\beta_{kj})_{n \times n}$ is irreducible and $R_0 > 1$, and assume that;

$$\alpha_k S_k + (\mu_k + \theta_k) V_k - (\mu_k + \gamma_k) E_k \geq 0 \quad (8)$$

then system 2 is uniformly persistent and there exists an endemic equilibrium \mathbf{E}^* and it is globally asymptotically stable in $\Gamma(\mathbb{R}^5)$.

Proof. Let v_1, \dots, v_n , be a basis for system (2), $\overline{B}v = 0$ as defined in lemma (3.2). Consider the following Lyapunov function;

$$F = \sum_{k=1}^n v_k \left\{ S_k - S_k^* - \frac{S_k^* \ln S}{S_k^*} + V_k - V_k^* - \frac{V_k^* \ln V}{V_k^*} + E_k - E_k^* - \frac{E_k^* \ln E}{E_k^*} + I_k - I_k^* - \frac{I_k^* \ln I}{I_k^*} \right\}$$

Computing the derivatives of F with respect to t along solutions of system (2) gives;

$$\frac{dF}{dt} = \sum_{k=1}^n v_k \left\{ \left(1 - \frac{S_k^*}{S_k}\right) \frac{dS_k}{dt} + \left(1 - \frac{V_k^*}{V_k}\right) \frac{dV_k}{dt} + \left(1 - \frac{E_k^*}{E_k}\right) \frac{dE_k}{dt} + \left(\frac{\mu_k + \gamma_k}{\gamma_k}\right) \left(1 - \frac{I_k^*}{I_k}\right) \frac{dI_k}{dt} \right\} \quad (9)$$

Substituting the first four terms of system (2) into equation (9)

$$\begin{aligned} \frac{dF}{dt} = & \sum_{k=1}^n v_k \left\{ \left(1 - \frac{S_k^*}{S_k}\right) \left\{ \Lambda_k - \sum_{j=1}^n \frac{\beta_{kj} S_k I_j}{N} - (\mu_k + \alpha_k) S_k \right\} \right. \\ & + \left(1 - \frac{V_k^*}{V_k}\right) \left(\alpha_k S_k - \sum_{j=1}^n \frac{\beta'_{kj} V_k I_j}{N} \right) + \left(1 - \frac{E_k^*}{E_k}\right) \left(\sum_{j=1}^n \frac{\beta_{kj} S_k I_j}{N} + \sum_{j=1}^n \frac{\beta'_{kj} V_k I_j}{N} \right) \\ & \left. - (\mu_k + \gamma_k) E_k + \left(\frac{\mu_k + \gamma_k}{\gamma_k}\right) \left(1 - \frac{I_k^*}{I_k}\right) \left\{ \gamma_k E_k - (\mu_k + \delta_k + \pi_k) I_k \right\} \right\} \quad (10) \end{aligned}$$

Expanding equation (10) yields;

$$\begin{aligned}
\frac{dF}{dt} = & \sum_{k=1}^n v_k \left\{ \mu_k S_k^* - \mu_k S_k - \frac{\mu_k S_k^{*2}}{S_k} + \mu_k S_k^* + (\mu_k + \theta_k) V_k^* - (\mu_k + \theta_k) \frac{S_k^* V_k^*}{S_k} \right. \\
& + (\mu_k + \theta_k) V_k^* - (\mu_k + \theta_k) V_k + (\mu_k + \theta_k) V_k^* + (\mu_k + \theta_k) V_k^* - (\mu_k + \theta) \frac{V_k^{*2} S_k}{V_k S_k^*} \\
& + \left(\sum_{j=1}^n \frac{\beta_{kj} S_k^* I_j^*}{N} + \sum_{j=1}^n \frac{\beta'_{kj} V_k^* I_j^*}{N} \right) - \sum_{j=1}^n \frac{\beta_{kj} S_k^{*2} I_j^*}{S_k N_j} - \sum_{j=1}^n \frac{\beta'_{kj} V_k^* I_j S_k^*}{S_k N} \\
& + \sum_{j=1}^n \frac{\beta_{kj} S_k^* I_j^*}{N} - \sum_{j=1}^n \frac{\beta_{kj} V_k^{*2} S_k I_j^*}{V_k S_k^* N} + \sum_{j=1}^n \frac{\beta'_{kj} V_k^* I_j^*}{N} - \left(\sum_{j=1}^n \frac{\beta_{kj} S_k I_j}{N} \right. \\
& + \sum_{j=1}^n \frac{\beta'_{kj} V_k I_j}{N} \left. \right) \frac{E_k^*}{E_k} + \left(\sum_{j=1}^n \frac{\beta_{kj} S_k I_j}{N} + \sum_{j=1}^n \frac{\beta'_{kj} V_k I_j}{N} \right) \\
& \left. - \frac{\mu_k + \gamma_k}{\gamma_k} (\mu_k + \delta_k + \pi_k) I_k - (\mu_k + \gamma_k) \frac{E_k I_k^*}{I_k} + \frac{\mu_k + \gamma_k}{\gamma_k} (\mu_k + \delta_k + \pi_k) I_k^* \right\}
\end{aligned} \tag{11}$$

Factorizing equation (11) yields;

$$\begin{aligned}
\frac{dF}{dt} = & \sum_{k=1}^n v_k \left\{ \mu_k S_k^* \left(2 - \frac{S_k}{S_k^*} - \frac{S_k^*}{S_k} \right) + \sum_{j=1}^n \frac{\beta_{kj} S_k^* I_j^*}{N} \left(2 - \frac{S_k^*}{S_k} + \frac{I_j}{I_j^*} - \frac{S_k I_j E_k^*}{S_k^* I_j^* E_k} \right) \right. \\
& + \sum_{j=1}^n \frac{\beta'_{kj} V_k^* I_j^*}{N} \left(3 - \frac{S_k^*}{S_k} + \frac{I_j}{I_j^*} + \frac{V_k I_j}{V_k^* I_j^*} - \frac{V_k I_j E_k^*}{V_k^* I_j^* E_k} \right) \\
& \left. + \alpha_k S_k \left(1 - \frac{V_k^*}{V_k} \right) + (\mu_k + \theta_k) V_k^* \left(1 - \frac{V_k}{V_k^*} \right) - (\mu_k + \theta_k) E_k \left(\frac{E_k^*}{E_k} - \frac{I_k^*}{I_k} \right) \right\}
\end{aligned} \tag{12}$$

Using the relation $2 - \frac{S_k}{S_k^*} - \frac{S_k^*}{S_k} \leq 0$, for all $S_k > 0$ and assumption (8) gives;

$$\begin{aligned}
\frac{dF}{dt} \leq & \sum_{k=1}^n v_k \left\{ \sum_{j=1}^n \frac{\beta_{kj} S_k^* I_j^*}{N} \left(2 - \frac{S_k^*}{S_k} + \frac{I_j}{I_j^*} - \frac{S_k I_j E_k^*}{S_k^* I_j^* E_k} \right) \right. \\
& \left. + \sum_{j=1}^n \frac{\beta'_{kj} V_k^* I_j^*}{N} \left(3 - \frac{S_k^*}{S_k} - \frac{S_k}{S_k^*} + \frac{I_j}{I_j^*} + \frac{V_k I_j}{V_k^* I_j^*} - \frac{V_k I_j E_k^*}{V_k^* I_j^* E_k} \right) \right\}
\end{aligned} \tag{13}$$

Equation (13) can be expressed as;

$$\begin{aligned}
\frac{dF}{dt} = & \sum_{k=1}^n v_k \left\{ \sum_{j=1}^n \frac{\beta_{kj} S_k^* I_j^*}{N} \left[\left(1 - \frac{S_k^*}{S_k} + \ln \frac{S_k^*}{S_k} \right) + \left(\frac{I_j}{I_j^*} - \frac{E_k^*}{E_k} \right) - \ln \frac{I_j E_k^*}{I_j^* E_k} \right] \right. \\
& \left. + \sum_{j=1}^n \frac{\beta'_{kj} V_k^* I_j^*}{N} \left[\left(2 - \frac{S_k}{S_k^*} - \frac{S_k^*}{S_k} \right) + \left(1 - \frac{I_j}{I_j^*} \right) + \frac{V_k I_j}{V_k^* I_j^*} - \frac{V_k I_j E_k^*}{V_k^* I_j^* E_k} \right] \right\}
\end{aligned} \tag{14}$$

$$\begin{aligned} \frac{dF}{dt} = & \sum_{k=1}^n v_k \left\{ \sum_{j=1}^n \frac{\beta_{kj} S_k^* I_j^*}{N} \left[\left(1 - \frac{S_k^*}{S_k} + \ln \frac{S_k^*}{S_k}\right) + \left(\frac{I_j}{I_j^*} - \frac{E_k^*}{E_k}\right) - \ln \frac{I_j E_k^*}{I_j^* E_k} \right] \right. \\ & \left. + \sum_{j=1}^n \frac{\beta'_{kj} V_k^* I_j^*}{N} \left[\left(1 - \frac{I_j}{I_j^*} + \ln \frac{I_j}{I_j^*}\right) + \left(\frac{V_k}{V_k^*} - \frac{E_k^*}{E_k}\right) - \ln \frac{V_k E_k^*}{V_k^* E_k} \right] \right\} \end{aligned} \quad (15)$$

$$\begin{aligned} \frac{dF}{dt} \leq & \sum_{k=1}^n v_k \left\{ \sum_{j=1}^n \frac{\beta_{kj} S_k^* I_j^*}{N} \left[\left(\frac{I_j}{I_j^*} - \frac{E_k^*}{E_k}\right) - \ln \frac{I_j E_k^*}{I_j^* E_k} \right] \right. \\ & \left. + \sum_{j=1}^n \frac{\beta'_{kj} V_k^* I_j^*}{N} \left[\left(\frac{V_k}{V_k^*} - \frac{E_k^*}{E_k}\right) - \ln \frac{V_k E_k^*}{V_k^* E_k} \right] \right\} \end{aligned} \quad (16)$$

Equation (16) can be written as;

$$\frac{dF}{dt} = \sum_{k=1}^n v_k \left\{ M_1 + M_2 \right\}$$

where;

$$M_1 = \sum_{j=1}^n \frac{\beta_{kj} S_k^* I_j^*}{N} \left\{ \frac{I_j}{I_j^*} - \frac{E_k^*}{E_k} \right\} + \sum_{j=1}^n \frac{\beta'_{kj} V_k^* I_j^*}{N} \left\{ \frac{V_k}{V_k^*} - \frac{E_k^*}{E_k} \right\}$$

and

$$M_2 = \sum_{j=1}^n \frac{\beta_{kj} S_k^* I_j^*}{N} \left\{ \ln \frac{I_j E_k^*}{I_j^* E_k} \right\} + \frac{\beta'_{kj} V_k^* I_j^*}{N} \left\{ \ln \frac{V_k E_k^*}{V_k^* E_k} \right\}$$

$\frac{dF}{dt} = 0$ holds if and only if; $M_1 = 0$ and $M_2 = 0$.

$M_1 = 0$ implies that;

$$S_k = S_k^*, \quad V_k = V_k^* \quad \text{and} \quad \frac{E_k}{E_k^*} = \frac{I_k}{I_k^*}$$

$$\begin{aligned} E_k &= a E_k^* \\ I_k &= a I_k^* \end{aligned} \quad (17)$$

Substituting equation (17) in the second equation of system 2 gives;

$$\alpha_k S_k - \sum_{j=1}^n \frac{\beta'_{kj} a V_k I_j}{N} - (\mu_k + \theta_k) V_k \quad (18)$$

Comparing equation (18) with the second equation of system (2), the two equations are equal if and only if $a = 1$. Therefore $S_k = S_k^*, V_k = V_k^*, E_k = E_k^*, I_k = I_k^*, R_k = R_k^*$, It

follows from $\overline{B}v = 0$ and $\overline{B}v^1 = 0$, that;

$$\sum_{j=1}^n \beta_{kj} v_j = \sum_{i=1}^n \beta_{ki} v_k; \quad \sum \beta'_{kj} v_j = \sum \beta'_{ki} v_k$$

To show that $M_2 = 0$ that is;

$$\sum_{j=1}^n \frac{\beta_{kj} S_k^* I_j^*}{N} \left(\ln \frac{I_j E_k^*}{I_j^* E_k} \right) + \frac{\beta'_{kj} V_k^* I_j^*}{N} \left(\ln \frac{V_k E_k^*}{V_k^* E_k} \right) = 0$$

holds. By lemma (3.2), $\{v_1, v_2, ..v_n\} = \{C_{11}, C_{22}, \dots, C_{nn}\}$. Consequently each term in $v_k \overline{\beta}_{kj}$ is a product of n $\overline{\beta}_{ij}$ whose sub indices define transformations and are represented by directed arcs in a unicyclic graph Q .

$v_k = C_{kk}$ represents the sum of all rooted spanning directed subtrees T of G of vertex k . The directed arc from a vertex k to j forms a unicyclic subgraph Q of G . Therefore each term $v_k \overline{\beta}_{kj}$ represets the weights of a unicyclic subgraph. The double sum in M_2 is considered as the sum over all arcs in the cycle of all unicyclic subgraphs.

$$\begin{aligned} M_2 &= \sum_Q w(Q) \cdot \sum_{T \in \mathcal{T}_i(kj) \in E(CQ)} \ln \frac{I_j E_k^*}{I_j^* E_k} \\ &= \sum_Q w(Q) \cdot \ln \left(\prod_{T \in \mathcal{T}_i(kj) \in E(CQ)} \frac{I_j E_k^*}{I_j^* E_k} \right) \end{aligned}$$

and

$$\prod_{T \in \mathcal{T}_i(kj) \in E(CQ)} \frac{I_j E_k^*}{I_j^* E_k} = 1$$

Therefore;

$\ln \left(\prod_{T \in \mathcal{T}_i(kj) \in E(CQ)} \frac{I_j E_k^*}{I_j^* E_k} \right) = 0$. This as well applies to, $\ln \left(\prod_{T \in \mathcal{T}_i(kj) \in E(CQ)} \frac{V_k E_k^*}{V_k^* E_k} \right) = 0$. Since M_1 and $M_2 = 0$, it therefore follows that the only compact invariant subset of the set where $\frac{dF}{dt} = 0$ is the singleton \mathbf{E}^* . By the La Salle's invariance principle [7], \mathbf{E}^* is globally stable in Γ . Theoretically, this implies persistence of the disease in the population. \square

4 Application to Ebola Virus Disease

In this section, the study shows the applicability of the main theoretical results. Moreover, effects of vaccination and age on the transmission dynamics of EVD are discussed. Consider the system with $n = 3$, structured according to age under 5 years (group 1), above 6 -49 years (group 2) and above 50 years (group 3).:

$$\begin{aligned}
\frac{dS_1}{dt} &= (1 - \rho - \phi)\Lambda - \sum_{j=1}^3 \frac{\beta_1 c_{1j} S_1 I_j}{N} - (\mu_1 + \alpha_1)S_1 & (19) \\
\frac{dV_1}{dt} &= \alpha_1 S_1 - \sum_{j=1}^3 \frac{\beta_1 c_{1j} V_1 I_j}{N} - (\mu_1 + \theta_1)V_1 \\
\frac{dE_1}{dt} &= \sum_{j=1}^3 \frac{\beta_1 c_{1j} S_1 I_j}{N} + \sum_{j=1}^3 \frac{\beta_1 c_{1j} V_1 I_j}{N} - (\mu_1 + \gamma_1)E_1 \\
\frac{dI_1}{dt} &= \gamma_1 E_1 - (\mu_1 + \delta_1 + \pi_1)I_1 \\
\frac{dR_1}{dt} &= \pi_1 I_1 + \theta_1 V_1 - \mu_1 R_1 \\
\frac{dS_2}{dt} &= \phi\Lambda - \sum_{j=1}^3 \frac{\beta_2 c_{2j} S_2 I_j}{N} - (\mu_2 + \alpha_2)S_2 \\
\frac{dV_2}{dt} &= \alpha_2 S_2 - \sum_{j=1}^3 \frac{\beta_2 c_{2j} V_2 I_j}{N} - (\mu_2 + \theta_2)V_2 \\
\frac{dE_2}{dt} &= \sum_{j=1}^3 \frac{\beta_2 c_{2j} S_2 I_j}{N} + \sum_{j=1}^3 \frac{\beta_2 c_{2j} V_2 I_j}{N} - (\mu_2 + \gamma_2)E_2 \\
\frac{dI_2}{dt} &= \gamma_2 E_2 - (\mu_2 + \delta_2 + \pi_2)I_2 \\
\frac{dR_2}{dt} &= \pi_2 I_2 + \theta_2 V_2 - \mu_2 R_2 \\
\frac{dS_3}{dt} &= \rho\Lambda - \sum_{j=1}^3 \frac{\beta_3 c_{3j} S_3 I_j}{N} - (\mu_3 + \alpha_3)S_3 \\
\frac{dV_3}{dt} &= \alpha_3 S_3 - \sum_{j=1}^3 \frac{\beta_3 c_{3j} V_3 I_j}{N} - (\mu_3 + \theta_3)V_3 \\
\frac{dE_3}{dt} &= \sum_{j=1}^3 \frac{\beta_3 c_{3j} S_3 I_j}{N} + \sum_{j=1}^3 \frac{\beta_3 c_{3j} V_3 I_j}{N} - (\mu_3 + \gamma_3)E_3 \\
\frac{dI_3}{dt} &= \gamma_3 E_3 - (\mu_3 + \delta_3 + \pi_3)I_3 \\
\frac{dR_3}{dt} &= \pi_3 I_3 + \theta_3 V_3 - \mu_3 R_3
\end{aligned}$$

where $\beta_{kj} = \beta_k c_{kj}$, β_k is the probability of transmission between a susceptible individual in age group k with an infected individual and c_{kj} is the average number of contacts from individuals in age groups j with individuals in age group k . Other parameters have the same meaning like in the general model.

4.1 Numerical Results and Analysis

In this section the numerical results of model (19) and its analysis are presented. The parameter values used in the simulation are either obtained from literature and others were from assumptions to better understand the impacts vaccination has on different age groups. Matlab software was used to illustrate the numerical results describing the theoretical results.

Table 1: Parameter values used in simulation

Parameters	Description	Range	Source
N	Population size	230,000	Estimated
β_1	Infection rate	0.1680×10^{-6}	Varies
β_2	Infection rate	0.5154×10^{-7}	Varies
β_3	Infection rate	0.2857×10^{-11}	Varies
θ	Recovery rate for vaccinated	0.8	Varies
π	Recovery rate of the infected	0.9	Estimated
μ	Natural death rate	$[0, 1]day^{-1}$	[23]
δ	Disease induced death rate	$[0.5]day^{-1}$	[9]
α	Vaccination rate	0.18(0.16-0.202)	Varies
$\frac{1}{\gamma}$	Incubation period	1 week	

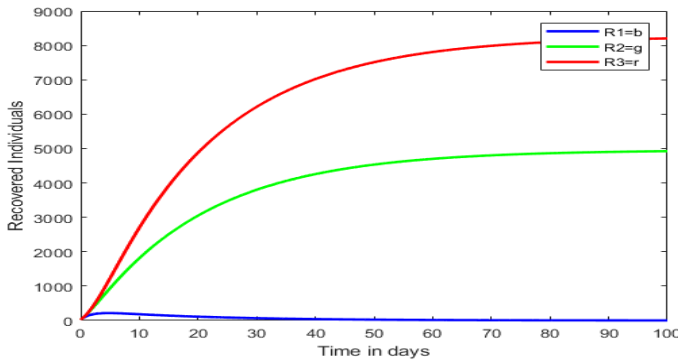

Figure 2: Graph of recoveries for age group under 5 years (R_1) in absence of Vaccination ($\alpha = 0$) and ($\alpha = 0.5$ for ages above 6 to 49 years (R_2) and above 50 (R_3))

Vaccination for children under 5 years has not been explored for the previous Ebola outbreaks, however a Mvabea 2 dose vaccine regimen is declared safe for children from 1 year old. Figure (2) illustrates how recoveries of children below 5 years would be in the absence of vaccination. The previous lack of vaccination as an intervention strategy for this age group might have been the reason for the high case fatalities as compared to other age groups, since at the onset of the infection the clinical symptoms of EVD are similar to those of other childhood infections. This together with the rapid disease progression are the causes of high fatality rates.

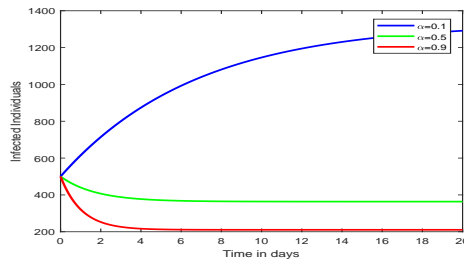

Figure 3: Impact of Vaccination on reducing infections in age group 1

From figure (3) and figure (4) it can be deduced that the higher the rate of vaccination the lower the number of infections to age groups 1 and 2. This indicates that to reduce the number of EVD infections, vaccination rate should be near perfect, i.e the target population should be vaccinated at nearly 100%.

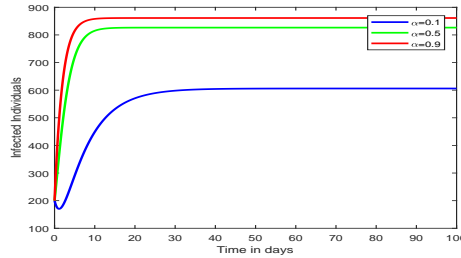

Figure 4: Impact of Vaccination on reducing infections in age group 3

4.2 Discussion

An individual's age is important in the disease dynamics and intervention measures. With a set of differential equations the dynamics of EVD was described by a system of general first order ordinary differential equations. Qualitative analysis was done for the general model. A threshold R_0 which determines whether the disease persists or dies out was computed. The disease free equilibrium is proved to be globally stable if $R_0 < 1$ and the endemic equilibrium is unique whenever $R_0 > 1$ and globally stable as tested using a graph theoretic approach on the method of Lyapunov functions. An example of a model with three age groups, under 5 years (group 1), above 6-49 years (group 2) and above 50 years (group 3) is given. Simulation was done with data from published literature on DRC. Analysis of different scenarios was done and demonstrates that children under 5 years should also be considered for a vaccination program in the fight against EVD. The simulation results also indicate that with effective vaccination $\alpha = 0.5 - 0.9$ the exposed population drops to nearly zero after some given number of days that is, they tend to the disease free equilibrium. For the older population vaccination is not very effective in reducing their susceptibility.

5 Conclusion

EVD is a disease that causes a great economic impact and has caused significant disease mortality among children under 5 years. Following its recurrence especially in Uganda and the DRC, the WHO suggests the need to include children under 5 years as case contacts. Due to the severity of the disease among children below 5 years and development of a vaccine that is safe for this population, it is important to consider vaccinating this age group to reduce disease mortality. The numerical simulation of a discrete age case

scenario demonstrates that vaccination of children under 5 years against EVD has a great impact in reducing their susceptibility to Ebola virus disease, this may be, because of the active immune system as compared to the older people who may have weak immunity and therefore response to vaccine immunity is poor.

6 Data availability

All data used to support the findings of the study are included within this article and can be obtained from the corresponding author upon request.

7 Conflict of interest

The authors declare that they have no conflict of interest.

References

- [1] Berman, A. and Plemmons, R.J. (1994). *Non-negative Matrices in the Mathematical Sciences*, Academic Press, New York,1994.
- [2] Elvebac L, et al.(1971). *Stochastic two-agent epidemic simulation models for a 379 community of families*. Amer.J.Epidemiol. 267-280.
- [3] Guo, H., Li, M. and Shuai, Z (2006). *Global stability of the endemic equilibrium of multigroup SIR epidemic models*. Can. Appl. Math.Q., 14, 259-284.
- [4] Hethcote H.W.(2000). *The mathematics of infectious diseases*. SIAM Rev. 42; 599-653.
- [5] Horn, R.A and Johnson, C.R. (2012). *Matrix Analysis*. Cambridge university press.
- [6] Korobeinikov A. and Melnik A.V.(2013). *Global properties for SIR and SEIR age Structured models*. Centre De Recerca Matematica (CRM).
- [7] LaSalle, J.P. (1976). *The stability of dynamical systems*. Regional Conference Series in Applied Mathematics. Society for Industrial and Applied Mathematics, Philadelphia.
- [8] Lisa S. (2019). *New data shows gaps in Ebola treatment for young kids*. cidrap.umn.edu/news-perspective/2019/05/new-data-show-gaps-ebola-treatment-young-kids.
- [9] Martcheva M. (2015) *An Introduction to Mathematical Epidemiology*. Springer, New York.
- [10] Moon, J.W.(1970) *Counting Labelled Trees*. Canadian Mathematical Congress.
- [11] Van Driesche and James Watmough (2002). *Reproduction Numbers and Sub-threshold Endemic Equilibria for Compartmental Models of Disease Transmission*. Mathematical Biosciences 100, 29-48.

- [12] World Health Organization Health Emergencies programme, (2019). *proposed recommendations regarding Ebola vaccination of lactating women and infants below 1 year of age*. R and D Blueprint.