

Combined Natural Dye Extractor and Dryer Fabrication Process

Abstract-Much interest has risen in the use of natural dyes due to intensified awareness of the environmental and health hazards associated with synthetic dyes. This study fabricated a cost-effective dye extractor and dryer machines for optimal dye extraction process. The fabrication was carried out considering engineering principles, durability, optimum performance, serviceability, ease of operation and cost effectiveness. The machines use a three-phase electric power with heating elements of 2400 W attached to the water jacket to guarantee satisfactory heating of the materials as they pass through the bottom chamber. The machine efficiency was determined through extraction of natural dye from roselle flower, at optimum parametric conditions of temperature, time and feed material. The results obtained revealed throughput capacity of 4 g/min, machine and extraction efficiencies of 78.61 and 84 % respectively. The fabricated machine produced a stable red coloured dye extract suitable for use in textile, food and pharmaceutical industries.

Key words: *Design and production, Extractor machine, Evaporator, Extraction, Natural Dye*

1. INTRODUCTION

The demand for natural products is on the increase as days go by. The trend is likewise practiced in dyeing industries. In the last few decades, progress has not only been made in moral strategies to the sustainable production of natural dyes, however, many new establishments, of various magnitudes, have commenced farming, extraction and application of natural dyes. There are two major inspirations guiding natural dye approaches, which are, returning of traditional artisanal systems of a particular province and engineering manufacture of coloured clothes that are eco-friendly.

Natural dyes/colourants have been used since the existence of man. They are derived from naturally occurring sources such as plants, insects (e.g., cochineal, beetles and lac scales insects), animals (e.g., some species mollusk or shellfish) and mineral (e.g., ferrous sulfate, ochre, and clay) with no form of chemical treatment[1]. The use of natural dyes in textile dyeing industries is greatly on the increase as a result of the toxic nature of synthetic dyes which may be carcinogenic, potential contamination and other risk associated with processing. They were extensively and locally used in the past before the emergence of synthetic dyes in 1856 [2]. Natural dyes are used in the wall paintings of the Egyptian pyramids, and in other ancient civilizations. According to Ashis and Adwaita[3], textile materials (natural and synthetic fibers) are usually coloured for value addition, appearance and desire of the customers. However, the purpose of colouring textile materials was initiated using colours obtained from natural sources, until synthetic colours/dyes were invented and commercialized. Ashis and Adwaita[3] reported that synthetic dyes of different types and classes are readily available and cost effective over natural dyes. However, synthetic dyes are produced through hazardous chemical processes which can pose a serious threat towards the ecosystem. One of the topics of discussion nowadays across the globe is the worry about environmental issues and sustainability. In the current world in which sustainability and concern for individual residues are emerging as a concept, there is a tendency towards a cleaner industry with better use of energy, that can substitute synthetic materials wherever possible, for raw materials derived from renewable resources to be used in a rational manner in order to be preserved in nature [4]. Consequently, strict regulations and awareness programs have been introduced to encourage the use of natural dyes from plants and animals. This has led to a rise in the overall production of natural dyes across the globe with a growing need to find suitable and less toxic alternative sources to synthetic dyes. Many countries have already imposed stringent environmental standards over synthetic dyes through the Environmental Board (EB) and Pollution Control Board (PCB). Germany, for instance, has banned the use of azo dyes[5-6]. Consequently, Padma [7] reported that natural dyes are in the forefront today due to the ban imposed on the use of synthetic dyes throughout the globe. Unfortunately, natural dye in Nigeria has not been widely available in powder form, hence cannot be stored for a long time. The colour is less stable and the process takes a long time so it is less practical in its use. Besides, natural dye industries nearly vanished towards the middle of 19th century and since then it is practiced in few pockets of the selected states in India.

The production of natural dye powders from plants involves a series of operations which includes extraction, drying and solvent recovery which are targeted towards obtaining a high percentage dye yield. More so, extraction medium and temperature are the major prevailing factors on the extraction yield and dye performance. However, research revealed that the extraction equipment in existence is not efficient, thereby hindering the ability to fully utilize natural dyes for colouration of textiles. Machine design is based on the use of experimental ideologies, high-tech facts and thoughts in the depiction of the machine or the mechanical scheme to execute distinctive tasks by means of utmost economy and effectiveness. This can also be an innovative and highly continual approach [8]. Besides, machine design comprises methods of creation, development, envision, computation, modification, rectification and description of specifics that standardize the mode of a product [9]. The fabrication of natural dye extractor that will enable high yield, be eco-friendly and meet with consumer's demand is of paramount importance. There are various conventional and non-conventional techniques that are used to extract natural dyes from plants. These techniques include aqueous, alkaline water, acidic/water, alcohol/water, soxhlet extraction techniques, ultrasonic, supercritical fluid, supercritical water, magnetic stirring techniques amongst others[10-12]. Conventional extraction approaches such as aqueous and soxhlet extraction methods have been reported [13-14]. Though their yields were not as much as in pilot scale. The extraction of these natural colorants from natural sources are extensively carried out conventionally and locally due to lack of technical-know-how, and the yields are not always encouraging. Nevertheless, some advanced conventional extraction techniques such as ultrasound, magnetic stirring, supercritical carbon dioxide and subcritical water extractions have been reported with increased dye extract, reduced cost, energy and time, but lead to environmental pollution [12],[15-16]. Treatment of effluents from this equipment is capital intensive. However, this can be overcome by the adoption and commercialization of natural dye extractors which are highly compatible with the environment and ecosystem. Fabrication of local solvent extractor machine with high feed capacity have not been reported to the best of our knowledge. The fabrication of an electrically-powered natural dye extractor and dyer machine at optimum temperatures are beneficial and will help improve the quality and yield of dye extracts which can in turn take care of environmental issues and sustainable development. This study was designed considering the increasing demand for the development of appropriate techniques for a more efficient, higher loading capacity and effective extraction process for natural colourants and other active substances from natural sources (plants, animals and mineral substances). Accordingly, the machines fabricated produced high extract yield that is stably red, enabled solvent recovery, time and energy saving and in turn will reduce the level of volatile organic compounds/pollution in the environment. The fabricated extractor and dryer machines can be used to produce marketable high-capacity powder dyes.

2.0 MATERIALS AND METHODS

2.1. Machine Description

The components of the dye extractor and dryer machines are: condensers, electric panel, electric water pump, heaters and electric vacuum pump. The designed equipment was based on the proposed process of the extraction of natural dyes [17]. The machines consist of two stainless cylindrical tanks: the extractor and the solvent collector; both are linked together through a condenser. Two loading/off-loading ports were provided on the extractor for the fresh/used feedstock respectively, a jacket insulated vessel surrounding half of the extractor from the middle to its base, with thermostat heaters which directly heat the water in the jacket.

A solvent extraction process was adopted with the concepts of evaporation, recirculation, percolation, refluxing, and distillation. The extractor consists of two chambers which are separated by a percolator closed mesh: the bottom chamber where the solvent was poured into, and the top chamber where the feed material (feedstock or ground plant) was loaded into. The feedstock (sorrel calyces) was contacted with heated solvent through the process of evaporation, percolation and recirculation of solvent for a given period of time and temperature. The solvent evaporates from the bottom of the reactor to the top chamber to extract the targeted colorant from the feed matter. Electric heat was then applied to heat the water in the jacket which in turn heats the solvent via the process of heat transfer (convection and conduction). At the beginning of the extraction process, valves 1&2 were locked for a period of time to ensure percolation, recirculation and refluxing of the condensed solvent back to the reactor to wash down the extracted colourant into the bottom chamber. Later, the two valves were opened and the condensed solvent then flowed and collected in the second cylindrical tank. The condenser cooled the solvent through water recirculation. At the end of the extraction process, concentrated extract with little solvent settled at the base of the reactor which was then collected through a base valve to the dryer. The dryer also consists of two stainless cylindrical tanks

with a condenser to evaporate the remaining solvent in order to obtain solid powder extract of the plant material.

2.2. Material Selection

In the present study, good materials were selected to accomplish the following goals: high extract yield, high extraction efficiency, high dye quality, availability, cost effectiveness, extractor that will accommodate the required feed material, strong stands for structural stability and strong support to the machines [18]. The materials used for the construction of the extractor and dryer machines are stainless steel sheets and pipes, stainless steel electrodes, nuts, bolts, saw paper, valves and mesh.

In order to promote local content and cost reduction, extractor and dryer machines were fabricated with locally accessible engineering materials. The machine components are condensers, solvent collectors, water jackets, extract container, all fabricated with stainless steel of thickness 2.2 mm.

2.3. Machine Design

2.3.1. Design of the Extractor

$$\text{Average bulk density of sorrel petals, } \rho_b = \frac{\rho_{min} + \rho_{max}}{2} \quad (1)$$

$$\text{Volume of bed for 5kg of sorrel petal, } V_b = \frac{m_h}{\rho_b} \quad (2)$$

Design to allow equal volume for: space above the feedstock bed, V ; space for the feedstock bed, V ; space above the solvent, V ; and space for solvent, V .

$$\text{Total volume of reaction} = 4xV \quad (3)$$

Allow for a height to diameter ratio to be 4:1 for reduction in retention time and significant increase in the purity of the extract.

$$\text{Therefore, } V = \frac{\pi D^2 H}{4} \quad (4)$$

Where V = volume of the reactor, m^3 ; H = height of the reactor, m ; and D = diameter of reactor, m .

$$\text{If, } H = 4D \quad (5)$$

$$\text{Therefore, } V = \frac{4\pi D^3}{4} = \pi D^3 \quad (6)$$

$$\text{Hence, } D = \left(\frac{V}{\pi}\right)^{\frac{1}{3}} \quad (7)$$

The extractor was designed to an annular space of 30 mm to allow for the water jacket with thermostat heaters. The heater was controlled with a temperature control panel that monitors the temperature of the solvent. The various views of the designed machines are presented in Figure 1.

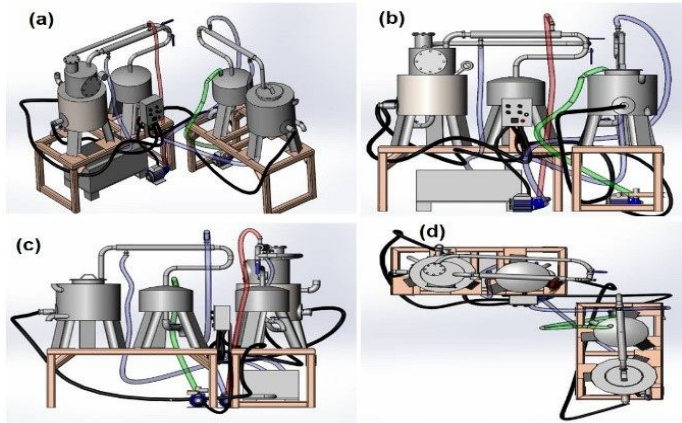

Figure 1. Different views of the fabricated machines (a) Assembled Extractor and Dryer Machines (b) Front view (c) side view (d) Top view.

2.3.2. Design of the Solvent Recovery Tank

The volume of the solvent recovery tank was designed to be 1.5 multiplied by the volume of the solvent used for the extraction[19], with a solvent to solid ratio of 5:1, to allow for insignificant solvent concentration on the extract in addition to high extract yield attainment[[20].

For 5kg of the initial feed material: Quantity of solvent = 5 X 5 = 25 liters

$$\text{Therefore, } V_s = 1.5 \times Q_s \quad (8)$$

Design to allow equal size of height and diameter of the tank;

$$\text{Therefore, } H = D \quad (9)$$

$$V = \frac{\pi D^2 H}{4} = \frac{\pi D^3}{4} \quad (10)$$

2.3.3. Design of the Dryer Equipment System

The dryer is an evaporator that separates solvent from the extract to form powder. It consists of two tanks, which are connected by a condenser. The first tank has a water jacket which is lagged with fiber to prevent heat loss. The heat is generated through an electric heater, and then transferred by convection and conduction. As the heat of conduction evaporates the solvent, the solvent is compressed by the condenser, and then flows down into the second tank, which serves as a solvent recovery tank. The 3D, isometric and orthographic drawings of the machines are shown in Fig. 2&3.

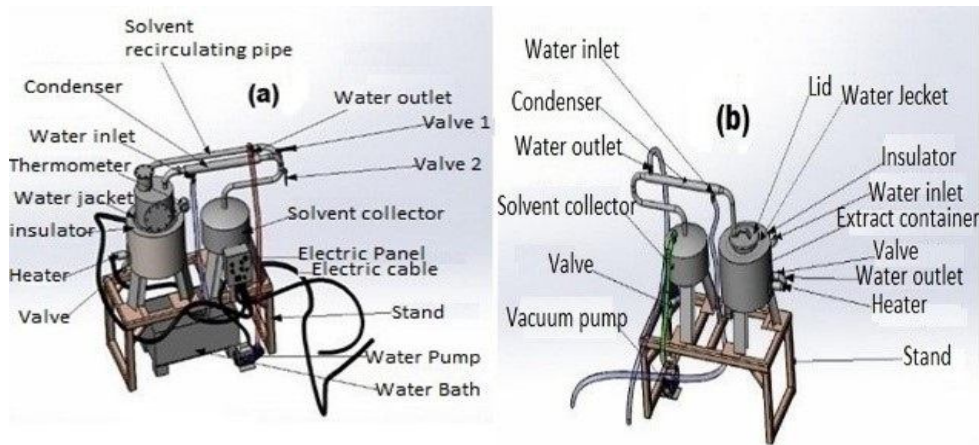

Figure 2. 3D drawing of the (a) Extractor and (b) Dryer Machine with their parts.

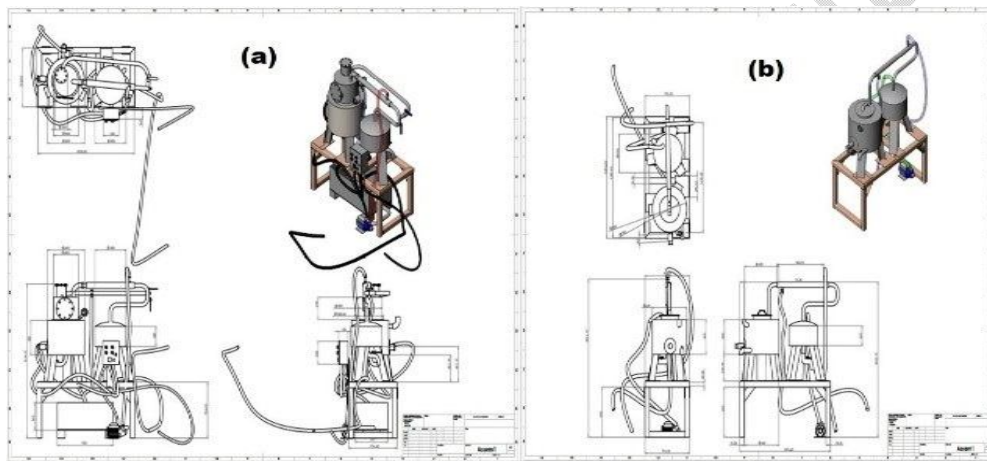

Figure 3. Isometric and Orthographic Drawing of (a) Extractor and (b) Dryer Machines.

2.4. Electric Energy Requirement

2.4.1. Determination of the Heating Element Rate

$$\text{Power of the electric heater, } P = \frac{\text{Energy}}{\text{Time}} = VI = \frac{V^2}{R} \quad (11)$$

Where I is the current, V is voltage and R is resistance

Work done to pass current through conductor is given by

$$W = VIT \quad (12)$$

2.4.2. Heat Transfer

The useful energy (heat) for the extraction of natural dye from material source (plant) by the extractor is equivalent to the heat transferred from the boiling water to the extractive solvent (ethanol).

The heat, Q transferred from the boiling water to heat ethanol can be described as follows,

$$\begin{aligned} Q &= UA\Delta T \\ &= UA (T_o - T_i) \end{aligned} \quad (13)$$

Where, U is the overall heat transfer coefficient

A is the exposed surface area to the boiling water in the jacket

T_o is the outside wall temperature (boiling water)

T_i is the inside wall temperature (boiling ethanol)

It is assumed that at the point of vapourization of ethanol to the feed material, the outside wall temperature is equal to the boiling point of water, and the inside wall temperature is equal to the boiling point of ethanol.

Therefore, $T_o = 100^\circ\text{C} = (100 + 273)\text{K} = 373^\circ\text{K}$

$T_i = 78^\circ\text{C} = (78 + 273)\text{K} = 351^\circ\text{K}$

So, $\Delta T = (T_o - T_i) = 373 - 351 = 22^\circ\text{K}$

Exposed area (A) = $2\pi r (r + h)$ (14)

As used in the extractor design:

Outside diameter (D_{ma}) of the concentric cylinder of the extractor = 600mm

Thickness of the jacket wall = 50mm

The exact outside diameter = $600 - (2 * 50)$

= $600 - 100 = 500\text{mm}$

Inside diameter (D_{mi}) of the concentric cylinder (inner cylinder) of the extractor = 400mm

So, the hydraulic diameter = $500 - 400 = 100\text{mm}$

= 0.1m

Hydraulic radius (r) = $0.1/2 = 0.05\text{m}$

Height of the cylinder = 350mm

= 0.35m

From equation (14), Exposed area (A) = $2 * 3.142 * 0.05 (0.05 + 0.35)$

= 0.12568m^2

$\approx 0.1257 \text{m}^2$

The overall heat transfer coefficient can be expressed as follows,

$$1/U = 1/h_1 + l/\lambda + 1/h_2 \quad (15)$$

Where U is the overall heat transfer coefficient

h_1 is the convective heat transfer coefficient of boiling water

h_2 is the convective heat transfer coefficient of boiling solvent (ethanol)

l is the thickness of the stainless steel of the extractor

λ is the thermal conductivity of stainless steel used

$h_1 = 2,000\text{W/m}^2\text{K}[21]$

$h_2 = 1300\text{W/m}^2\text{K}[21]$

$l = 2.2\text{mm} = 2.2 * 10^{-3} \text{m}$

$\lambda = 15\text{W/Km}$

from question (15), $1/U = 1/2000 + 2.2 * 10^{-3}/15 + 1/1300$

$$= 5 * 10^{-4} + 1.467 * 10^{-4} + 7.69 * 10^{-4}$$

$$= 10^{-4} (5.0 + 1.467 + 7.69)$$

$$= 14.657 * 10^{-4}$$

$$\text{So, } U = 1/14.657 * 10^{-4}$$

$$= 10000/ 14.657$$

$$= 682.268\text{W/m}^2\text{K}$$

$$\text{From equation (13), } Q = 682.268 * 0.1257 * 22$$

$$= 1886.7\text{W}$$

Power rating of the two heaters on the machine (heat input), $q = 1200\text{W} * 2 = 2400\text{W}$

$Q = \text{useful heat (heat output)} = 1886.7\text{W}$

The design consideration data is given in Table 1.

Table 1. Design Consideration Data

SN	Property	Symbol	Value	Unit
1	Average bulk density of sorrel petals	ρ_b	525	kg/m^3
2	Volume of bed for 5kg of sorrel petal	V_b	9.5	liters
3	Total volume of reaction	V	38	liters
4	Diameter of reactor (when; H=4D)	D	0.229	m
5	Height of the reactor (when; H=4D)	H	0.916	m
6	Quantity of solvent	Q_s	25	liters
7	Volume of solvent tank	V_s	37.5	liters
8	Diameter of reactor (when; H=D)	D	0.36	m
9	Power of the electric heater	P	1200	W
10	Current	I	5.5	A
11	Workdone	W	72.6	kJ
12	Overall heat transfer coefficient	U	682.268	$\text{W/m}^2\text{K}$
13	Height of cylinder	h	0.45	m
14	Surface area of contact	A_c	0.41	m^2
15	Final temperature	T_0	100	$^{\circ}\text{C}$
16	Internal temperature	T_1	78	$^{\circ}\text{C}$
17	Major cylinder area	A_1	0.85	m^2
18	Minor cylinder area	A_2	0.44	m^2
19	Heat input	q	2400	W
20	Heat output	Q	1886.7	W

2.4.3. Determination of stand Stress and Strain

The direction of the weight of the extractor and dryer exacted on their stands is shown in Figure 4. The extractor and the dryer machines on top of the stands subject the stands to stress, which may result in deformation of the machines.

The stress and strain are calculated utilizing the equations below [22].

$$\text{Stress} = \frac{\text{Force}, F}{\text{Area}, A} \quad (16)$$

$$\text{Where, } F = ma \quad (17)$$

$$A = \pi r^2 \quad (18)$$

$$\text{Strain} = \frac{\text{Extension}}{\text{Length}} \quad (19)$$

$$\text{Young's modulus, } E = \frac{\text{Stress}}{\text{Strain}} \quad (20)$$

Young's Modulus or Modulus of Elasticity is utilized most commonly for metals. It is essential to analyze all mechanisms, forces and properties of material in order to achieve accurate results. The machine element was designed to be strong enough to sustain all the forces in order not to be damaged or permanently deformed during its expected life time. From Fig. 4, the maximum stress exerted on the stand was given by $1.001 \times 10^7 \text{ N/m}^2$ with a yield strength of $1.7 \times 10^8 \text{ N/m}^2$, which resulted to a factor of safety (FoS) of 16.98, indicating that the produced stands are strong enough to withstand the load exerted on it by the extractor and dryer machines.

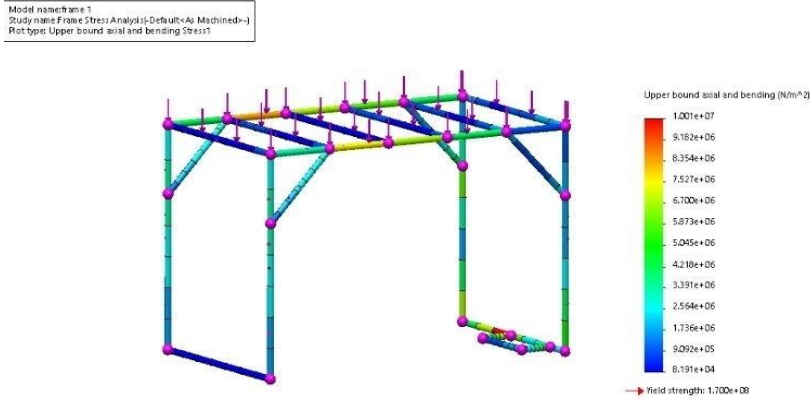

Figure 4. Stress analysis of the stand

2.5. Fabrication of Solvent Extraction and Dryer Machines

The two machines were fabricated using stainless steel for their built structure based on the design description. The individual components were designed and fabricated owing to the fabrication process shown in Fig. 5. In this process, the materials were marked and cut out to the required shape and dimension. The various shapes/parts were then joined together by welding to form the machine components. The fabricated components were then assembled to obtain the desired machines as seen in Figure 6.

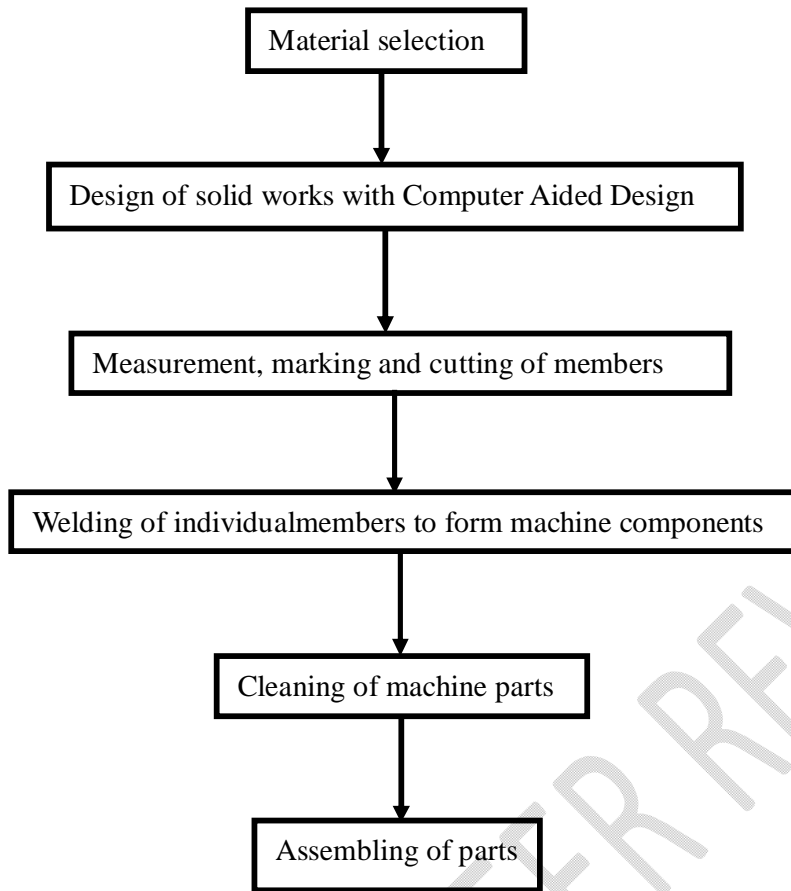

Figure 5. Flow chart of the design procedure



Figure 6. The macroscopic image of the fabricated natural dye extractor and dryer machines.

2.6. performance evaluations of the fabricated machines

A series of dye extraction process from Hibiscus sabdariffa flower was performed using the fabricated machines to determine the throughput capacity, machine and extraction efficiencies. The Hibiscus sabdariffa flower was dried and ground to reduce the flower size. Extraction was carried out using three parameters, which are temperature, time and feed material with ethanol as the extractive

medium to evaluate the performance of the fabricated machines. The feed material was measured and poured into the extraction machine through the pork, followed by addition of the extraction medium (solvent). The port was then closed and tightened with bolts and nuts. Heat transfer was achieved through the passage of electric current from the heater into the water in the jacket. This in turn heated the solvent to evaporate to the feed material chamber. The pigment was then extracted from the feed material through mass transfer into the solvent chamber by percolation, reflux and recirculation with the help of the condenser. At the end of the extraction, the extract with the solvent was collected through the valve which is beneath the extractor, and the time taken by the dryer to evaporate the solvent from the extract yield was noted. The throughput capacity, machine and extraction efficiencies were calculated using Eqns. (21 – 23) as given below.

2.7. Throughput Capacity

Throughput is the average number of units being produced on a machine over a specified period of time. Throughput capacity is the rate at which a good number of units goes through the process per unit time. This is calculated using equation 21. In this process, a total number of 20 experimental runs was performed employing some parametric conditions of temperature, time and feed material. Within a temperature of 100 °C, the total average units produced by the fabricated machine was 7531.99g with a total average of 2100 min, Table 2. This resulted in a throughput capacity of 3.586g/min, which is approximately 4g/min.

$$\text{Throughput capacity} = \frac{\text{total units produced}}{\text{time}} \quad (21)$$

2.8. Machine Efficiency

Machine efficiency is defined as the ratio of the output energy to that of input. This was calculated using Equation (22). This ratio gave a machine efficiency of 78.61%.

$$\begin{aligned} \text{Machine Efficiency, } \eta &= \frac{\text{energy output}}{\text{energy input}} \times 100 \quad (22) \\ &= 1886.7 / 2400 * 100 \\ &= 0.786125 * 100 \\ &\approx 78.61\% \end{aligned}$$

2.9. Extraction Efficiency

The extraction efficiency determines the effectiveness of the machine to extract dyes from natural sources. This is a measure of the ratio of the yield x weight of the feed material before extraction to the percentage (%) content of the material. This was obtained using equation 23. In this approach, a total average yield of 7531.99g with a total average mass of 40kg having a percentage content of 358.6 The extraction efficiency was obtained to be 84%.

$$\text{Extraction efficiency, } EE = \frac{\text{yield} \times \text{total mass}}{\% \text{ content}} \quad (23)$$

The extraction efficiency obtained in this study is higher than those obtained with ultrasound and magnetic stirrer as reported in the literature [23].

The fabricated machine exhibit potentials over other classical techniques (Soxhlet extraction, steam distillation etc.) with lesser solvent consumption, solvent recovery and extraction speed. It is noteworthy that the extract yield obtained with the fabricated extractor is comparatively higher than those reported in the literature for steam-distillation extraction (0.2 %), reflux extraction (2.2 %) and Ultrasound-assisted extraction (2.3 %) [24].

Table 2. Design matrices showing the effect of parametric conditions on the yield

Run	Independent variable			Response variable
	Temperature (°C)	Time (min)	Feed material	Yield (%)

			(Kg)	Actual	Predicted	Residual
1	90	180.68	2	5.75	5.86	-0.11
2	80	150	1	12.18	12.00	0.18
3	80	60	3	17.32	17.18	0.14
4	100	150	3	9.85	6.67	3.18
5	90	105	2	26.43	26.33	0.20
6	90	105	2	36.32	26.33	9.99
7	100	60	1	68.16	63.08	5.08
8	73.18	105	2	35.46	31.96	3.50
9	90	105	0.32	28.74	31.12	-2.38
10	106.82	105	2	44.18	50.12	-5.94
11	80	60	1	17.65	19.10	-1.45
12	90	105	3.68	8.01	8.08	-0.07
13	90	105	2	27.41	26.33	1.08
14	90	105	2	25.87	26.33	-0.46
15	90	29.32	2	19.51	21.84	-2.33
16	100	60	3	20.12	18.58	1.54
17	100	150	1	33.76	32.18	1.58
18	80	150	3	25.71	29.07	-3.36
19	90	105	2	21.46	26.33	-4.87
20	90	105	2	20.93	26.33	-5.40

From the performance evaluations on the fabricated extractor, it was observed that the fabricated machines utilized 60 min to extract dye with a yield of 68 % at a temperature of 100 °C and 1 kg feed material. The dye extract obtained was free from traces of residual solvent and heavy metals with reddish colour stability. This technique is stress free and less time consuming unlike other conventional techniques such as Aqueous extraction and Supercritical Fluid Extraction (SFE) which leads to dye decomposition upon boiling [25], high cost of equipment, incapable of extracting polar compounds and requires longer time of extraction resulting from complicated high-pressure equipment and technologies respectively.

3.0. Conclusion

Natural dye extractor and dryer machines have been fabricated using locally and easily accessible materials with simple fabrication set-up. These machines consist of heating elements which directly heats the water in the jacketed (through heat transfer mechanism). This is a pilot scale extraction system which is a fashion of conventional extraction techniques. It is fabricated to enhance and increase the production of natural dyes from plant sources as alternative to conventional approaches. The performance of the fabricated systems was studied through extraction of plant dye from hibiscus sabdariffa (roselle) flower under optimal conditions of temperature, time and feed material. Accordingly, the fabricated system having throughput capacity of 4g/min, machine efficiency of 78.61 % and extraction efficiency of 84 %, can be effectively used for extraction of natural dyes without failure. The fabricated machine will boost green technique which is encouraged by the standard of Environmental Protection Agency, US in the areas of eco-friendly materials, energy efficiency, utilization of renewable materials, absence of degradation during extraction, pollution control, time friendly and safe materials for accident prevention. The dyes extract from the fabricated machines are suggested for application not only for colouration in textile industries, but can also be employed in food, medicine, pharmaceutical, cosmetic and printing industries as natural colourants.

Data availability statement

The authors confirm that the data and materials supporting the findings of this research are available within the article and its supplementary material.

Reference

- [1] Md. Hossain, I. (2021). Sources and applications of natural dyes. *Textile Focus*. <https://textilefocus.com/sources-applications-natural-dyes/#>, accessed 23/05/2022.
- [2] EKrani, E. and Goodarzian, H. (2010). Extraction of dye from nadder plant (rubiatictoniumlin) and dyeing of wool work. *World Applied Sciences Journal*, 9(4), 434-436.
- [3] Ashis, K.S and Adwaita, K. (2011). Dyeing of textiles with natural dyes, Dr. EmriyeAkcakocaKumbasar(Ed). In Tech. Available at: <http://www.intechopen.com/books/natural-dyes/dyeing-of-textiles-with-natural-dyes>.
- [4] Teresa, C.V., Caroline, S.P. and Eliane, A. (2015). Natural dyes in the design of textile. How to make them more competitive face to synthetic dyes. *Journal of the International Color Association*, 14, 14-27.
- [5] Vankar, G.Y., Contamine, F.X., Faid, A.M., William, J.C. and Berlan, H.D. (2007). Chemical reactions under ultrasound. *Chem.Eng.Sci.*, 49 (24), 5873.
- [6] Kamel, M.M.E., Shishtavy, R.M., Yusuf, B.M., and Mashaly, H. (2005). Ultrasonic-assisted dyeing. III. Dyeing of wool with lac as a natural dye. *Dyes and Pigments*, 65. 103-110.
- [7] Padma, R (2013). Title of Sub-project: A value chain in natural dyes. national agricultural innovation project (Indian Council of Agricultural Research) Retrieved on 30/7/2018.
- [8] George N, (2015). Design of Machine Elements, https://www.rajagiritech.ac.in/home/mech/Course_Content/Semester%20VII/ME%20401%20Design%20of%20Machine%20Elements%20I/Module%201.pdf. Accessed 9/8/2021.
- [9] Sundar, D (2018). Machine Design Procedure. <https://extrudesign.com/machine-design-procedure/>. Retrieved on 9/8/2021.
- [10] Nwachukwu, D. C., Aneke, E. I., Obika, L. F and Nwachukwu, N. Z. (2015). Effects of aqueous extract of *Hibiscus sabdariffa* on the renin-angiotensin-aldosterone system of Nigerians with mild to moderate essential hypertension: A comparative study with lismopril. *Indian J. Pharmacol*, 47 (5). 540-545.
- [11] Wanyama, P.A.G., Kiremire, B.T., Ogwok, A., and Murumu, J.B. (2010). Characterization of color from some dye-yielding plants in Uganda. *African Journal of Pure and Applied Chemistry*, 4(10), 233-239
- [12] Almahy, H. A, Ali, M. A, and Ali, A. A. (2013). Extraction of Carotenoids as Natural Dyes from the *Daucus carota* Linn (carrot) using Ultrasound in Kingdom of Saudi Arabia. *Research Journal of Chemical Sciences*, 3(1), 63–66.
- [13] Petvaiz, S. Mughal, T. A., Najeebullah, M. Khan, F. Z. (2016). Extraction of natural dye from *Rosa damascena miller*- a cost effective
- [14] Thiyagarajan, S., Balakrishnan, K., and Tamilarasi, S. (2015). A Study of Extraction and Dyeing Behavior of Natural Dye obtained from Cotton a Study. *IOSR Journal of Applied Chemistry (IOSR-JAC)*, 8(5), 85-89. www.iosrjournals.org
- [15] Viana, T. C., Pagnan, C. S. and Ayres, E (2015). Natural Dyes in the Design of Textile: How to make them more Competitive Face to Synthetic Dyes. *Journal of the Inter.Colour Association*, 14, 14-27.
- [16] Hassan, A. a., Hamada, H. A. Yasert, A. E. and Elhadi, M. I. (2015). Ultra-sound Extraction of Anthocyanin's as Natural Dyes from *Hibiscus Sabdariffa* (Karkade) And its Application on Dyeing Foodstuff and Beverages in Kingdom of Saudi Arabia. *American Journal of Biological and Pharmaceutical Research*.2(4), 168-174.

- [17] Sayem ANM, Ahmed F, Saha P and Talukder B. (2021). A Review on Natural Dyes: Raw Materials, Extraction Process, and their Properties. *Advance Research in Textile Engineering*. 6 (1), 1062.
- [18] Okolie, P. C., Chukwujike, I. C., Chukwuneke, J. L and Dara, J. E. (2019). Design and production of a fish feed pelletizing machine. *Heliyon* 5, e02001
- [19] FEDO (2020). Fact Engineering and Design Organization <https://fact.co.in/images/upload/> retrieved 20/10/2022.
- [20] Lamm, M.H. and Jarboa, L.R. (2021). *Chemical Engineering Separations: A Handbook for Students*. Ames, IA: Iowa State University Digital Press.
- [21] Alexandre, C. D., and Costin, S. B. (2000). *Chemical process design: compute-aided case studies*. Appendix B: heat exchanger design, 474-482
- [22] Erik, G. (2020). *Young's Modulus Physics*. Retrieved on, 19/6/2020.
- [23] Sivakumar, V., Vijaeeswarri, J. and Anna, J. L. (2011). Effective natural dye extraction from different plant materials using ultrasound. *Industrial Crops and Products* 33, 116–122.
- [24] Jiang, M. H., Yang, L., Zhu, L., Piao, J. H., & Jiang, J. G. (2011). Comparative GC/MS analysis of essential oils extracted by 3 methods from the bud of *Citrus aurantium* L. var. *amara* Engl. *Journal of food science*, 76(9), C1219-C1225
- [25] Batch, D.D. (2019). *Consumer acceptance of textile products dyed using recycled food waste*, ProQuest, Raleigh, North Carolina.