

# APPLICATION OF THE TRAPEZ-METHOD TO THE CALCULATION OF COUPLING MATRICES BETWEEN UNIAXIAL GUIDE MODES

## Abstract

In this paper, we determine the different possible couplings at the discontinuities of the two circular and rectangular waveguides using the trapez-method. The development of the normal modes of the fields allows us to obtain the amplitude of the fields of the transverse electric (TE) and magnetic (TM) modes. The calculation of the coupling integrals allows us to obtain the coupling matrices and to verify if the coupling is possible or not between the modes of these two waveguides.

**Key words:** coupling; discontinuities; waveguides; trapez-method.

## I. Introduction

Since decades, the theoretical and practical demonstrations of James Clerk Maxwell, Heinrich Hertz and John Lord Rayleigh developed in the years 1864 allowed the development of the first microwave systems. Multiple applications in the military and telecommunication fields have seen the day. The differential and integral forms of Maxwell's equations have continued to expand the horizon to a vast field of applications. A century later, as technological developments abounded, the advent of telecommunications made the elaboration of particular solutions to these equations even more urgent. The knowledge of the behavior of waves in guides is essential to make the transmission of high frequency signals more efficient [1-3].

Many methods have been used to model discontinuities in waveguides. These methods can be classified into two types: analytical methods, they are the oldest and date back to the 50s and 60s. Among these methods, we can mention the conformal transformation methods which have allowed the characterization of planar structures in the static and quasi-static cases [4-5], the variational techniques of Collin [5] and the numerical methods which can be divided into two families: the differential methods, based on the discretization in space of the Helmholtz equation and the integral methods [6, 7, 8, 9] which allow the determination of the distribution of currents or electric fields on the surfaces of discontinuities of the structure. The validity of these methods depends on the frequency domain, the accuracy required and the approach adopted.

At the level of literature, several researchers have worked on progressive transitions rectangular waveguides between an empty guide and a microstrip line as well as filters in waveguides loaded with dielectric over their entire height, sometimes using one of these methods [1],[10-12]. These transitions present a delicate question related to the study of the convergence of these parameters as a function of the number of accessible modes.

To palliate this problem, we are interested in the calculation of the different possible couplings at the discontinuities of two circular and rectangular guides using the Trapez-method.

In order to set up a library of coupling matrices at the transition level of these two guides for applications in instrumentation or telecommunications equipment, we will conduct a study on the calculation of coupling integrals. It consists in determining the coupling matrices between two circular and rectangular waveguides by the trapez- method. This method applies with good accuracy to uniaxial discontinuities without thickness in the direction of propagation.

## II. Theory

## II.1 rectangular waveguide

The homogeneous rectangular waveguide is a guide structure with a single conductor in the form of a hollow tube of rectangular section, the hollow part of which is filled with dielectric. Thus, Figure 1 shows the geometry of a rectangular waveguide of width  $a$  and height  $b$  filled with a homogeneous dielectric with constant permittivity  $\epsilon$  and permeability  $\mu$  [5].

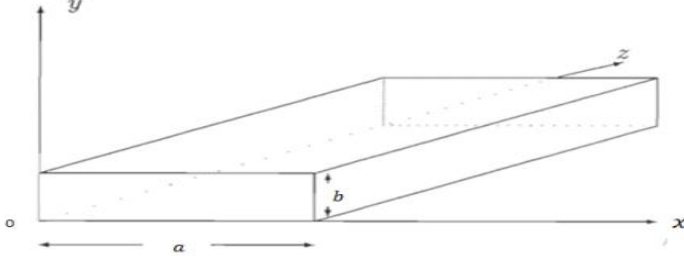

Figure 1: Right section of the rectangular waveguide

$E_z$  obeys the following Helmholtz equation

$$\nabla^2 F(x, y, z) + k^2 F(x, y, z) = 0 \quad (1)$$

Where  $F(x, y, z)$  is one of the components of the electric or magnetic field.

A solution of this equation is:

The components of the electric and magnetic fields of the modes  $TE_{mn}$

for the electric field.

$$\begin{cases} E_x = \frac{j\sqrt{2}}{k_{mn}} \left(\frac{m\pi}{b}\right) \cos\left(\frac{m\pi}{a}x\right) \sin\left(\frac{m\pi}{b}y\right) e^{-j\beta z} \\ E_y = \frac{j\sqrt{2}}{k_{mn}} \left(\frac{m\pi}{a}\right) \sin\left(\frac{m\pi}{a}x\right) \cos\left(\frac{m\pi}{b}y\right) e^{-j\beta z} \\ E_z = 0 \end{cases} \quad (2)$$

for the magnetic field

$$\begin{cases} H_x = \frac{j\sqrt{2}\beta}{\omega\mu_0 k_{mn}} \left(\frac{m\pi}{a}\right) \sin\left(\frac{m\pi}{a}x\right) \cos\left(\frac{m\pi}{b}y\right) e^{-j\beta z} \\ H_y = \frac{j\sqrt{2}\beta}{\omega\mu_0 k_{mn}} \left(\frac{m\pi}{b}\right) \cos\left(\frac{m\pi}{a}x\right) \sin\left(\frac{m\pi}{b}y\right) e^{-j\beta z} \\ H_z = \frac{\sqrt{2}k_z^2}{\omega\mu_0 k_{mn}} \cos\left(\frac{m\pi}{a}x\right) \cos\left(\frac{m\pi}{b}y\right) e^{-j\beta z} \end{cases} \quad (3)$$

The components of the electric and magnetic fields of the modes  $TM_{mn}$

for the electric field:

$$\begin{cases} E_x = \frac{2j}{k_c\sqrt{ab}} \left(\frac{m\pi}{a}\right) \cos\left(\frac{m\pi}{a}x\right) \sin\left(\frac{m\pi}{b}y\right) e^{-j\beta z} \\ E_y = -\frac{2j}{k_c\sqrt{ab}} \left(\frac{m\pi}{b}\right) \sin\left(\frac{m\pi}{a}x\right) \cos\left(\frac{m\pi}{b}y\right) e^{-j\beta z} \\ E_z = \frac{2k_c}{\beta\sqrt{ab}} \sin\left(\frac{m\pi}{a}x\right) \cos\left(\frac{m\pi}{b}y\right) e^{-j\beta z} \end{cases} \quad (4)$$

for the magnetic field:

$$\begin{cases} H_x = -\frac{2j\omega\epsilon}{\beta k_r \sqrt{ab}} \left(\frac{m\pi}{b}\right) \sin\left(\frac{m\pi}{a}x\right) \cos\left(\frac{m\pi}{b}y\right) e^{-j\beta z} \\ H_y = -\frac{2j\omega\epsilon}{\beta k_r \sqrt{ab}} \left(\frac{m\pi}{a}\right) \cos\left(\frac{m\pi}{a}x\right) \sin\left(\frac{m\pi}{b}y\right) e^{-j\beta z} \\ H_z = 0 \end{cases} \quad (5)$$

## II.2 circular cylindrical waveguides

The circular waveguide is a hollow metal cylinder of radius  $a$  (Figure 2). It is represented in the cylindrical coordinate system where the axis ( $oz$ ) is always defined as the propagation direction [5].

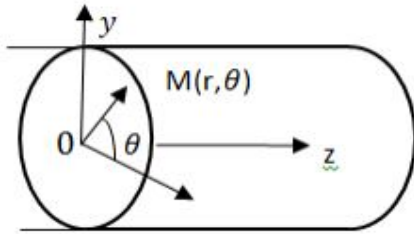

Figure 2: circular cylindrical waveguides

In a circular cylindrical waveguide of radius  $a$ , the generating functions  $\psi_h$  and  $\psi_e$  for the H and E modes are solutions of the following equation:

$$\frac{1}{r} \frac{\partial}{\partial r} \left( r \frac{\partial \psi_i}{\partial r} \right) + r \frac{\partial^2 \psi_i}{\partial r^2} + \frac{1}{r^2} \frac{\partial^2 \psi_i}{\partial \theta^2} + k_c^2 \psi_i = 0, \quad i = h, e \quad (6)$$

Where  $k_c^2 = \Gamma^2 + k_0^2$  and  $\psi_i = 0$  at  $r=a$  for E modes, and  $\frac{\partial \psi_i}{\partial r} = 0$  at  $r=a$  for H modes [5].

A solution of this equation is :

Components of the TM mode fields

For TM modes, the longitudinal component  $H_z$  is zero and  $E_z \neq 0$ .

Let's put

$$E_z(r, \theta) = F_0(r, \theta) e^{-j\beta z}$$

$$\text{Since } F_0(r, \theta) = A_{j_1}(j_c r) [A_1 \cos(\theta) + B_1 \sin(\theta)]$$

for the electric field:

$$\begin{cases} E_{r1n} = -j \sqrt{\frac{2}{\pi a_2}} \frac{J_2' \left( \frac{X_{2n}}{a_2} r \right)}{J_2' (X_{2n})} \cos(\theta) e^{-j\beta z} \\ E_{\theta 1n} = j \sqrt{\frac{2}{\pi r X_{2n}}} \frac{J_2 \left( \frac{X_{2n}}{a_2} r \right)}{J_2' (X_{2n})} \sin(\theta) e^{-j\beta z} \\ E_{z1n} = \sqrt{\frac{2}{\pi}} \frac{k_c^2 J_1 \left( \frac{X_{2n}}{a_2} r \right)}{\beta_{2n} X_{2n} J_2' (X_{2n})} \cos(\theta) e^{-j\beta z} \end{cases} \quad (7)$$

for the magnetic field:

$$\begin{cases} H_{r1n} = -j \sqrt{\frac{2}{\pi}} \frac{\omega \varepsilon J_1 \left( \frac{X_{1n} r}{a_1} \right)}{r \beta_{1n} X_{1n} J_1'(X_{1n})} \sin(\theta) e^{-j\beta z} \\ H_{\theta 1n} = -j \sqrt{\frac{2}{\pi}} \frac{\omega \varepsilon J_1' \left( \frac{X_{1n} r}{a_1} \right)}{a_1 \beta_{1n} J_1'(X_{1n})} \cos(\theta) e^{-j\beta z} \\ H_{z1n} = 0 \end{cases} \quad (8)$$

Components of the TE mode fields

For TE modes, the longitudinal component of the electric field is zero ( $E_z = 0$ ), and  $H_z \neq 0$  [5].

Let's put

$$H_z(r, \theta) = F_\theta(r, \theta) e^{-j\beta z}$$

for the electric field:

$$\begin{cases} E_{r1n} = -j \sqrt{\frac{2}{\pi}} \frac{J_2 \left( \frac{X'_{1n} r}{a_2} \right)}{r J_1(X'_{1n}) \sqrt{X'^2_{1n} - 1}} \cos(\theta) e^{-j\beta z} \\ E_{\theta 1n} = j \sqrt{\frac{2}{\pi}} \frac{X'_{1n} J_2' \left( \frac{X'_{1n} r}{a_2} \right)}{a_2 J_1(X'_{1n}) \sqrt{X'^2_{1n} - 1}} \sin(\theta) e^{-j\beta z} \\ E_{z1n} = 0 \end{cases} \quad (9)$$

for the magnetic field:

$$\begin{cases} H_{r1n} = -j \sqrt{\frac{2}{\pi}} \frac{\beta_{1n} X'_{1n} J_2' \left( \frac{X'_{1n} r}{a_2} \right)}{a_2 \mu_0 \omega J_1(X'_{1n}) \sqrt{X'^2_{1n} - 1}} \sin(\theta) e^{-j\beta z} \\ H_{\theta 1n} = -j \sqrt{\frac{2}{\pi}} \frac{\beta_{1n} J_2 \left( \frac{X'_{1n} r}{a_2} \right)}{r \mu_0 \omega J_1(X'_{1n}) \sqrt{X'^2_{1n} - 1}} \cos(\theta) e^{-j\beta z} \\ H_{z1n} = \sqrt{\frac{2}{\pi}} \frac{k_0^2 J_1' \left( \frac{X'_{1n} r}{a_2} \right)}{\mu_0 \omega J_1(X'_{1n}) \sqrt{X'^2_{1n} - 1}} \sin(\theta) e^{-j\beta z} \end{cases} \quad (10)$$

$X_{1n}$  and  $X'_{1n}$  are values of the roots of the TM and TE modes of the first kind Bessel functions defined for  $n = 1, 2, 3, \dots$

$$X_{1n} = \left(2n + \frac{1}{2}\right) \frac{\pi}{2} - \frac{3}{4\pi(2n + \frac{1}{2})} + \frac{9}{48\pi^2(2n + \frac{1}{2})^3} \quad (11)$$

$$X'_{1n} = \left(2n - \frac{1}{2}\right) \frac{\pi}{2} - \frac{3}{4\pi(2n - \frac{1}{2})} - \frac{9}{48\pi^2(2n - \frac{1}{2})^3} \quad (12)$$

the propagation constant  $\beta_{1n}$  defined by :

$$\beta_{1n} = \sqrt{\frac{\omega^2}{c^2} \varepsilon_r - k_{c1n}^2}$$

### II.3 Trapez-method

This is one of the methods of graphic origin used when the primitive of the function  $f$  is not easy to calculate or requires tedious calculations. This method allows to calculate an approximate numerical value of  $\int_a^b f(x) dx$  [13-14].

It consists in dividing the integration interval  $[a, b]$  by  $n$  small intervals  $[x_k, x_{k+1}]$  for  $k$  varying from 0 to  $n$ , with  $x_0 = a$  and  $x_n = b$ , and in replacing the function  $f$  to be integrated in each interval by the straight line passing through the points  $(x_k, f(x_k))$  and  $(x_{k+1}, f(x_{k+1}))$  [13-14]. Thus, in a general way, we have [13-14]:

$$\int_a^b f(x) dx = \sum_{k=0}^{n-1} I_k \quad (13)$$

Where

$$I_k = \int_{x_k}^{x_{k+1}} f(x) dx \approx (x_{k+1} - x_k) \left( \frac{f(x_k) + f(x_{k+1})}{2} \right)$$

In the case where the  $n$  small intervals are of equal length, then whatever

$0 \leq k \leq n-1$ ,  $x_k = a + kh$  for  $k=0,1,2,\dots,n$ ; where  $h = \frac{b-a}{n}$  is the length of  $n$  equal intervals.

The approximate value of the integral is:

$$I \approx \frac{b-a}{2n} \left[ f(a) + 2 \sum_{k=1}^{n-1} f\left(a + k \cdot \frac{b-a}{n}\right) + f(b) \right] \quad (14)$$

### III. Results and Discussion:

#### III.1 Coupling integral between the two waveguides

To study the interactions between propagation modes in waveguides, we are interested in the calculations of the coupling integrals between TE-TE, TE-TM, TM-TE, and TM-TM modes.

- a) Junction between a larger circular guide and a smaller rectangular guide

For this discontinuity, we will consider the cross-section of the rectangular guide smaller than that of the cylindrical guide. In this case, the Laplacian depends on the  $x$  and  $y$  components. Figure 3 shows this junction.

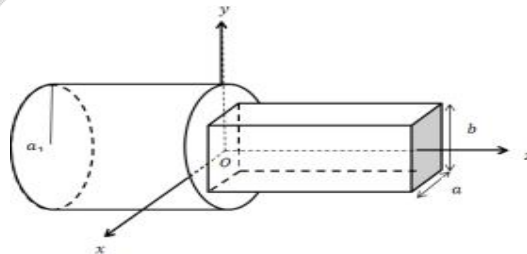

Figure 3 : Junction between a circular and a rectangular guide whose the surface of the rectangle being inferior than that of the circle.

- Coupling between TM-TM mode

In this coupling, we will perform a crossing between the electric field of the TM modes propagating in the guide (1) with the magnetic field of the TM modes propagating in the guide (2). Thus, the calculation expression is as follows:

$$M^{(TM-TM)} = \iint_S \vec{E}_{t1n}^{(1)} \times \vec{H}_t^{*(2)} ds \quad (15)$$

$$\iint_S \vec{E}_{t1n}^{(1)} \times \vec{H}_t^{*(2)} ds \vec{e}_z$$

$$\vec{E}_{t1n}^{(1)} \times \vec{H}_t^{*(2)} = [E_r \vec{e}_r + E_\theta \vec{e}_\theta] \times [H_x^* \vec{e}_x + H_y^* \vec{e}_y]$$

By applying the trapez-method in matlab and assigning arbitrary values to the numbers of small intervals  $n_x$  and  $n_y$ , we obtain by numerical simulation, the following matrix after convergence  $n_x = 70$  and  $n_y = 60$  :

$$M^{(TM-TM)} = 10^{-3} j \begin{pmatrix} 0.3781 & 0.0463 & -0.0368 & -0.0235 & 0.0419 & 0.0060 \\ 0.0376 & 0.1826 & 0.0313 & -0.0712 & 0.0139 & 0.0178 \\ -0.1353 & 0.0452 & 0.0834 & 0.0049 & -0.0366 & -0.0041 \\ 0.0145 & -0.1847 & 0.0181 & 0.1217 & -0.0235 & -0.0322 \\ 0.0839 & -0.0233 & -0.0477 & 0.0259 & 0.0296 & 0.0065 \\ -0.0249 & 0.2123 & -0.0105 & -0.1255 & 0.0282 & 0.0547 \end{pmatrix}$$

- Coupling between TE-TE mode

It is a crossing between the electric field propagating in the guide (1) in TE mode and the magnetic field propagating in the guide (2) in TE mode.

$$M^{(TE-TE)} = \iint_S \vec{E}_{t1n}^{(1)} \times \vec{H}_t^{*(2)} ds$$

$$\iint_S \vec{E}_{t1n}^{(1)} \times \vec{H}_t^{*(2)} ds \vec{e}_z$$

$$ds = dx dy, \quad 0 \leq x \leq a \quad \text{et} \quad 0 \leq y \leq b$$

$$M^{(TE-TE)} = 10^{-3} j \begin{pmatrix} -0.0582 & 0.1877 & -0.0173 & -0.0043 & -0.0017 & 0.0065 \\ 0.0266 & -0.2300 & -0.0060 & 0.3291 & -0.0526 & -0.0642 \\ 0.0612 & -0.0555 & -0.0138 & 0.0919 & -0.0173 & 0.0076 \\ -0.0208 & 0.1972 & -0.0152 & -0.2125 & 0.0297 & 0.0857 \\ -0.0672 & 0.0325 & 0.0037 & -0.0355 & 0.0028 & 0.0247 \\ 0.0156 & -0.1619 & 0.0132 & 0.1970 & -0.0332 & -0.0535 \end{pmatrix}$$

- Coupling between TM-TE mode

It is a crossing of the electric field of the TM modes propagating in the guide (1) with the magnetic field of the T E modes propagating in the guide (2). We have :

$$M^{(TE-TE)} = 10^{-3} j \begin{pmatrix} -0.0231 & 0.0307 & 0.0034 & -0.0092 & -0.0012 & 0.0017 \\ -0.0240 & 0.1477 & -0.0007 & -0.1011 & 0.0197 & 0.0439 \\ 0.0594 & 0.0305 & -0.0095 & 0.0158 & 0.0036 & -0.0042 \\ 0.0182 & -0.0876 & 0.0007 & 0.1214 & -0.0189 & -0.0443 \\ -0.0731 & -0.0139 & 0.0141 & 0.0195 & -0.0056 & 0.0098 \\ -0.0136 & 0.0701 & -0.0006 & -0.0861 & 0.0177 & 0.0570 \end{pmatrix}$$

- Coupling between TE-TM mode

It is a crossing between the electric field of the T E modes propagating in the guide (1) with the magnetic field of the TM modes propagating in the guide (2). The calculation expression is :

$$M^{(TE-TM)} = 10^{-3} j \begin{pmatrix} 0.1596 & 0.0435 & 0.0675 & -0.0161 & 0.0107 & -0.0018 \\ 0.1122 & -0.1740 & 0.0816 & 0.0757 & 0.0152 & -0.0130 \\ -0.0538 & -0.0361 & 0.0339 & 0.0150 & 0.0309 & 0.0017 \\ -0.1000 & 0.2773 & -0.0125 & -0.1417 & 0.0386 & 0.0250 \\ 0.0330 & 0.0283 & -0.0046 & -0.0138 & 0.0050 & -0.0019 \\ 0.0977 & -0.3281 & 0.0173 & 0.1929 & -0.0261 & -0.0359 \end{pmatrix}$$

These matrices show that at the junction between two circular and rectangular guides, the coupling between TM-TM, T E-T E, TM-T E and TE-TM mode fields are possible, the electric fields of the TM and TE modes and the magnetic fields of the TE and TM modes propagate at the separation surface of these two guides

#### b) Junction between a smaller circular guide and a larger rectangular guide

This is to consider that the area of the rectangular guide is greater than that of the cylindrical guide figure 4. In this case, the Laplacian depends on the r and  $\theta$  components. Figure 4 illustrates this junction.

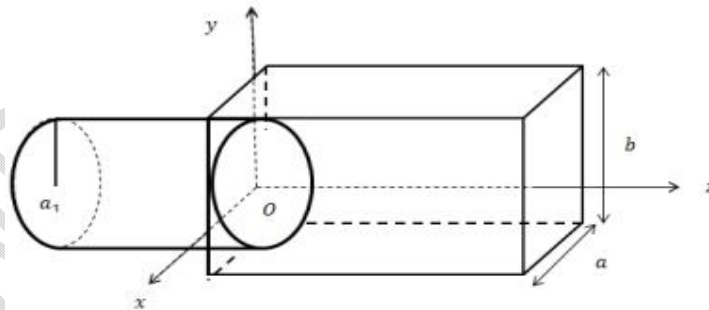

Figure 4 : Junction between a circular and a rectangular guide whose the surface of the rectangle being greater than that of the circle.

- Coupling between TM-TE mode

It is a crossing of the electric field of the TM modes propagating in the guide (1) with the magnetic field of the T E modes propagating in the guide (2). The calculation expression is:

$$M^{(TM-TE)} = \iint_S \vec{E}_{z1n}^{(1)} \times \vec{H}_z^{(2)} ds$$

$$\iint_S \vec{E}_{r1n}^{(1)} \times \vec{H}_r^{(2)} ds \vec{e}_z$$

$$\vec{E}_{r1n}^{(1)} \times \vec{H}_r^{(2)} = [E_{r1n} \vec{e}_r + E_{\theta1n} \vec{e}_\theta] \times [H_x \vec{e}_x + H_y \vec{e}_y]$$

Since the cross-sectional area of the rectangular guide is larger than that of the cylindrical guide, the Laplacian depends on the components r and  $\theta$ .

$$M^{(TM-TE)} = 10^{-3} j \begin{pmatrix} -0.0354 & 0 & 0.0551 & 0 & -0.0569 & 0 \\ -0.1234 & 0 & 0.1791 & 0 & -0.0942 & 0 \\ 0.0767 & 0 & -0.1297 & 0 & 0.1398 & 0 \\ -0.0114 & 0 & 0.0231 & 0 & 0.0283 & 0 \\ -0.064 & 0 & 0.1307 & 0 & -0.1505 & 0 \\ 0.0383 & 0 & 0.0418 & 0 & 0.0684 & 0 \end{pmatrix}$$

- Coupling between TE-TM mode

It is a cross between the electric field of the T E modes propagating in the guide (1) and the magnetic field of the TM modes propagating in the guide (2). The calculation expression is

$$M^{(TE-TM)} = j \begin{pmatrix} 0 & 0 & 0 & 0 & 0 & 0 \\ 0.0027 & 0 & 0 & 0 & 0 & 0 \\ -0.0002 & 0 & 0 & 0 & 0 & 0 \\ -0.0021 & 0 & 0 & 0 & -0.0001 & 0 \\ 0.0002 & 0 & 0 & 0 & 0 & 0 \\ 0.0018 & 0 & 0.0002 & 0 & -0.0001 & 0 \end{pmatrix}$$

- Coupling between TM-TM mode

In this coupling, we will perform a crossing between the electric field of the TM modes propagating in the guide (1) and the magnetic field of the TM modes propagating in the guide (2). Thus the calculation expression is as follows :

$$M^{(TM-TM)} = j \begin{pmatrix} 0 & 0 & 0 & 0 & 0 & 0 \\ 0.0031 & 0 & 0.0001 & 0 & 0 & 0 \\ -0.0002 & 0 & 0.0001 & 0 & -0.0001 & 0 \\ -0.0024 & 0 & -0.0002 & 0 & -0.0006 & 0 \\ 0.0002 & 0 & -0.0001 & 0 & 0.0001 & 0 \\ 0.0020 & 0 & 0.0011 & 0 & -0.0001 & 0 \end{pmatrix}$$

- Coupling between TE-TE mode

In this coupling, we will perform a crossing between the electric field of the TE modes propagating in the guide (1) and the magnetic field of the TE modes propagating in the guide (2). Thus the calculation expression is as follows :

$$M^{(TE-TE)} = j \begin{pmatrix} 0 & 0 & 0 & 0 & 0 & 0 \\ -0.024 & 0 & 0.0060 & 0 & -0.0019 & 0 \\ 0.0001 & 0 & 0 & 0 & 0 & 0 \\ 0.0212 & 0 & -0.0160 & 0 & 0.0062 & 0 \\ -0.0001 & 0 & 0 & 0 & 0 & 0 \\ -0.0128 & 0 & 0.0217 & 0 & -0.0115 & 0 \end{pmatrix}$$

These matrices show that at the junction between two circular and rectangular guides, the coupling between TE-TM, TM-TE and T E-TE modes are possible, the fields propagate partially at the separation surface of the two guides.

## Conclusion

In this paper, we have calculated the coupling integrals between the waveguide modes. The obtained results give us an idea of the different possible couplings during the propagation of the fields at the discontinuity surface. We can thus retain that for the various transitions carried out, all the modes can couple, which characterizes the total propagation of the fields for the first case considered, and the partial propagation of the fields for the second case considered at the surface of separation of its two waveguides.

## References

- [1] Charmolavy G. L. Nkouka Moukengue, Aristide Mankiti Fati, Nzonzolo, B. Mafouna Kiminou and Donald Ulrich Mboundou " Calculation of the Coupling Matrices on the Discontinuity between Rectangular Waveguide and Substrate Integrated Waveguide" Journal of Scientific and Engineering Research, 2022, 9(1):11-17
- [2] Lilonga-Boyenga D, Yalaoui A., Tao J.W., Vuong T.H., "Analysis of scattering by cylindrical post dielectric in rectangular waveguide by a new multimodal variational formulation", International Workshop on microwave filters, CNES, Toulouse France, september 2004.
- [3] D. Lilonga, J.W. Tao, T.H. Vuong, "Uniaxial discontinuities analysis by a new multimodal variational method: Application to filter design" International Journal of RF and microwave computer-aided engineering (numéro spécial "RF and microwave filters, modeling and design" ) 29 september 2005, pp 123-132
- [4] G. Ghione and C. Naldi ", Coplanar waveguide for MMIC applications : effect of upper shielding conductor backing, finite-extent ground planes, and line-to-line coupling ", IEEE Transactions on MTT, March. 1987, vol. 25, pp 260 – 267.
- [5] R. Collin, " Field theory of guided waves second edition ", IEEE Press, New-York, McGraw-Hill 1991.
- [6] H. Baudrand, " Méthodes numériques en propagation ", ENSEEIHT, 1985.
- [7] M. Helier, N. Ney, C. Pichot, " Structures de guidage HF ", E 1 171-1:15, Techniques de l'ingénieur, traité électronique.
- [8] S. C. Wu and Y. L. Chow, " An application of moment method to waveguide scattering problems ", IEEE Transactions on MTT, Nov. 1972, vol. 20, pp 749 – 759.
- [9] H. Auda and R. F. Harrington, " A moment solution for waveguide junction problems ", IEEE Transactions on MTT, July. 1983, vol. 31, pp 515 – 519.
- [10] A. Takacs, D. Lilonga, J.W. Tao, R. Crampagne, H. Aubert, R. Plana, P. Pons, M. Saadaoui, J. Ch., Cayrou, "Une nouvelle transition WR/CPW large bande pour satellites de communications en bande Ka ", 6ème Journées Microondes et Electromagnétisme de Toulouse, 29 janvier 2003.
- [11] A. Takacs, D. Lilonga, H. Aubert, J.W. Tao, P. Pons, R. Crampagne, R. Plana, J.Ch. Cayrou, "Design of a Broadband WR-to-CPWG Millimeterwave Transition", Microwave and Optical Technology Letters , October 2004.
- [12] M. Guglielmi and C. Newport, " Rigorous multimode equivalent network representation of inductive discontinuities ", IEEE Transactions on MTT, Nov. 1990, vol. 38, pp 1651 – 1659.

[13] A. F. Abdulhameed, Q. A. Memon, " An improved Trapezoidal rule for numerical integration" Journal of Physics: Conference Series, 2021, pp 1-9.

[14] Norm EGGERT and John LUND, " The trapezoidal rule for analytic functions of rapid decrease" Journal of Computational and Applied Mathematics January 1989, 389-406.

UNDER PEER REVIEW