

**Original Research Article**

# **Design of a Stand-Alone Photovoltaic Energy System for Small-Scale Business Outlets (Case Study of Arogbo Community in Ondo State)**

---

## **ABSTRACT**

This paper designed a stand-alone photovoltaic energy system for small-scale business outlets in rural areas, using Arogbo Community in Ese-Odo Local Government Area of Ondo State, Nigeria as a case study. Structured questionnaires were administered to 150 business outlets for energy audit. Total energy estimate and consumption for 8 hours daily operation were estimated from obtained information. Total energy demand of the outlets based on their appliances used per day with power factor of 0.8 and 15% tolerance for a maximum load of 355.228 kW was 1,894.844 kWh. The specific energy required for a typical outlet (Barbing Salon, Computer Centre and Hairdressing Shop) were (0.938, 9.04 and 10.87) kWh, and their photovoltaic equivalence were estimated as (1.266, 12.211 and 14.67) kWh respectively. The solar components for the outlets were estimated as (0.317, 3.053 and 3.66) kW solar modules on installation areas of (3, 28.4 and 34) m<sup>2</sup>. Inverter ratings of (0.22, 4 and 6) kVA were selected for the respective outlets. (1, 4, and 4) numbers of 12 V deep cycle batteries of (100, 150 and 150) AH were selected. Electricity generator capacities selected were (1, 4 and 6) kVA respectively.

**Keywords:** Stand-alone photovoltaic, inverter, generator, energy audit, specific energy

---

## 1. INTRODUCTION

Energy is a central cross-sectional issue that affects all human activities, either directly or indirectly. It plays an essential role in the overall frame work of developmental planning and economic growth of any nation. Modern economy ways of life are almost impossible without reliable, constant and affordable supplies of energy [1]. Access to energy is fundamental for socio-economic development and poverty alleviation [2]. People in developing countries have extremely low access to energy, and the developed countries consume far more energy than the developing countries, suggesting that access to energy is the dividing line between the developed and the developing countries of the world [3].

The challenges faced by Nigerian government are how to reach out to the rural communities that do not have access to electricity and modern energy services despite the large energy potentials in Nigeria. Most of the rural areas lack reliable supply of electricity as a result of low generation and distribution of energy. These areas remain underdeveloped and backward in business, because, some of the artisans and small business owners find it difficult to run their businesses as a result of no electricity or high cost of electricity billing and environmental factors related to the distance from existing utility grid. As a result, most houses and small-scale business owners obtained their electricity from petrol- and diesel-powered generators that have adverse effect on the ecosystem. This dependence on generators caused a large consumption of fuel of poor quality, which caused a severe damage to the air quality and environment [4].

The environmental risks associated with the use of fossil fuels to power generators and vehicles in Nigeria have caused a great concern for Nigerians because it leads to release of greenhouse gases which resulted in global warming. Also, the noise from generators causes noise pollution and this affects the wellbeing of the rural users [5]. Besides the environmental issues, the financial implication for running them every day is very huge and this make researchers to consider renewable energy which is clean, reliable, affordable and environmentally friendly. According to [6], Nigeria has an installed

generating capacity of 12 MW but with a generating capacity of 4 MW and as a result of this poor energy supply prompted people to divert into the use of an alternative means of energy supply.

Renewable energy sources such as solar energy remain the most viable option to alleviate the problems of electricity generation from fossil-fueled power station since it is clean and environmentally friendly. It is the alternative power source that would overcome the fears of running out of fossil fuel [7]. Nigeria is blessed with abundance of renewable energy potentials such as wind, biomass, geothermal etc., but the country is still facing an energy crisis, which has a major impact on the ability to reduce poverty and promote economic growth. Renewable energy resources transform the passive energy to a clean active energy used to generate electric power with no emission these include photovoltaic (PV) system being a most popular renewable energy resource since electricity generation by solar energy does not need fuel, the costs of maintenance is low, produces no pollution and noise [5].

The steady generation of alternative energy to reduce cost of running small scale businesses with petrol generator in rural areas is determined by the potential availability of renewable energy resources. According to [8], some countries have successfully utilized grid connected solar energy to produce electricity for residential homes, small scale businesses, workshop and many more. Researches have shown that more efforts have been made to combine the electricity generated by the solar with other sources to build hybrid power system with about 90% of the required power supplied by renewable energy sources [9]. [10] analyzed the potential implementation of hybrid photovoltaic (PV)/wind turbine/diesel system in Southern city of Malaysia, where seven different system configurations were studied. Also, [11] investigated the potential operation of hybrid energy system in the Northern city in Africa in which several system configurations with and without battery storage elements were studied. [2], developed off-grid hybrid energy system for residential buildings in rural areas. In their study, three different types of accommodations (three-bedroom Luxury, three-bedroom Convenience and room with parlour) were evaluated for energy requirements. These were estimated to be 10.015kWh, 3.216 kWh and 1.736 kWh

respectively and their photovoltaic (PV) energy system capacities were estimated to be 13.53 kWh (16.91 kVA), 4.342 kWh (5 kVA) and 2.344 kWh (2.93 kVA) with power factor of 0.8

The photovoltaic (PV) systems offer consumers ability to generate electricity in a clean, quiet and reliable way. Photovoltaic systems consist of photovoltaic cells that convert light energy from the sun directly to electricity [12; 13]. A standalone PV system generates electricity during the daylight to supply the demand and charge the batteries while at night and cloudy days; it depends on the battery bank to supply the demand load. The PV panels and batteries generate DC power and the inverter converts it to AC power in order to supply the load. A typical Standalone PV system is shown in Figure 1. Many researchers in the field of renewable energy have investigated the design, operation, optimization and cost analysis of a Stand-alone PV system for rural household electrification. [14], presented the design of a stand-alone PV system for a typical residential building in Bauchi, Nigeria based on medium energy consumption. [5], designed a 21.12 kWp stand-alone PV system to feed three departmental laboratories loads in AL-Nabrain University, Baghdad to ensure power continuity. Also, in the work of [15], a stand-alone PV system was designed as a power source for an ozone monitor laboratory at Anyigba, North Central, Nigeria. Photovoltaic/wind-based hybrid power system connected to a common bus with battery storage and conventional backup source to supply 2 kW telecommunication load was proposed for use in Malaysia [16]. Although, photovoltaic system has the disadvantage of high initial cost of procurement of components such as batteries, pv arrays,

inverters and controller. However, it becomes cheaper on the long run as it attracts very low maintenance cost [5; 7]

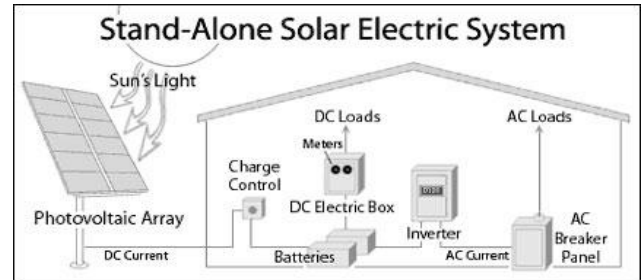

Figure 1: A Standalone PV System [17]

This study aimed at designing a stand-alone PV system to generate electricity for small scale business outlets in a rural area at affordable prices

## 2. MATERIALS AND METHODS

### 2.1 Study Area

The area under study in this paper is Arogbo Community located in Ese-Odo Local Government Area of Ondo State in the South-Western part of Nigeria. The geographical location of the community is shown in Figure 2. It is on Latitude 6.26° North and Longitude 4.9967° East with elevation of 5 m. It falls under the tropical climate region with rainy season between April and October and dry season between November and March. Arogbo Community has a population of 13,857 as recorded in the population census conducted in the year 2006 [18].



Figure 2: Google Map showing Arogbo Community [2]

### LEGEND

|       |                |
|-------|----------------|
| ●     | Communities    |
| ----- | State Boundary |
| ■     | Greeks         |

## 2.2 Research Questionnaire

In order to determine the total energy demand of the study area, a well-structured questionnaire was distributed and administered to about 150 small scale business outlets (barbing salon, computer service shop and hairdressing shop) to obtain information on the energy consumption patterns of their businesses based on the number of appliances used per day. Responses from the questionnaire were used to determine the energy audit of the area.

## 2.3 Methods

### 2.3.1 Energy Demand of the Study Area

Arogbo community is relatively sun-rich region with an annual solar irradiation of about 2190 kWh/m<sup>2</sup>/year and with average temperature of 27°C. The average sunshine hour per day is 6 hours since the sunshine hours in the study area is between 3-9 hours per day. The energy demand was estimated based on the number of appliances for each business, power rating of the appliances and the time of usage of each appliance as obtained from the research questionnaire administered. Standard equations were used in determining the various energy parameters as discussed in Akinola *et al.*, 2022.

### 2.3.2 PV Energy Sizing

#### a) PV energy Required by each Appliances

The amount of energy needed by the photovoltaic PV system for each appliance in each business outlet was evaluated using Equation 1

$$P_A = P_T \times H_D \quad (1)$$

where:

$P_A$  is the amount of energy needed by each appliance per day in Watt-hour,  $P_T$  is the total power consumption of each of the appliances in Watts (W) and  $H_D$  is the average number of hours used per day by each of the appliances

#### b) Total PV Energy Required

In the design of PV system for any facilities, losses due to dirt, heat dissipation, resistance in the wire, inverter losses, batteries and PV module losses must be accounted for. The total energy required to power the study area and the losses accounted for were estimated using Equations 2 and 3 respectively [19].

$$S_p = \sum_{i=1}^n (P_A) \quad (2)$$

$$PL = PL_{PV} + PL_H + PL_D + PL_W + PL_I + PL_B \quad (3)$$

where:

$S_p$  is the total energy required to power the area under study,  $PL$  is the total power losses in the appliances,  $PL_{PV}$  is the power losses due to the PV modules,  $PL_H$  is the power losses due to heat dissipation,  $PL_D$  is the power losses due to dirt and dust in the solar panel,  $PL_W$  is the power losses due to wiring and mismatch,  $PL_I$  is the inverter power losses and  $PL_B$  is the power loss in the battery system.

Therefore, the total PV energy ( $E_{TPV}$ ) required by each of the appliances in the area was evaluated using Equation 4

$$E_{TPV} = S_p + PL \quad (4)$$

#### c) Sizing of PV arrays System

The PV arrays needed for each of the small-scale businesses under study were estimated using Equation 5 [20]. For efficiency and effectiveness, the PV arrays should be positioned in the right tilt angle for maximum absorption of solar energy intensity.

$$S_{PV} = \frac{E_{TPV}}{R_H} \times \varepsilon_F \quad (5)$$

where:

$S_{PV}$  is the PV arrays size,  $E_{TPV}$  is the total PV energy required by each of the appliances,  $R_H$  is the average sunshine hour per day and  $\varepsilon_F$  is the efficiency factor assumed to be 1.5 in this study for effectiveness of the PV array system.

#### d) Number of PV Panel Required

In determine the total number of PV panel needed for the PV array system, the panel generation factor (PGF) is an important factor used to determine the total watt-peak for the PV panel capacity. The panel generation factor and the total watt-peak were determined using Equations 6 and 7 respectively.

$$PGF = S_{irrad} \times T_{CF-PV} \quad (6)$$

$$P_{WPP} = \frac{E_{TPV}}{PGF} \quad (7)$$

where:

$S_{irrad}$  is the average irradiation of the study area,  $T_{CF-PV}$  is the total correction factor for the PV arrays and  $P_{WPP}$  is the total watt-peak for the PV panel capacity

Then, the total number PV panel needed for the PV array system is given in Equation 8

$$N_p = \frac{P_{WPP}}{P_{max}} \quad (8)$$

where:

$N_p$  is the number of panels needed for the PV arrays; and  $P_{max}$  is the rated maximum power of the solar panel.

#### e) Sizing of the Inverter System

The sizing of the inverter was done based on the size of the PV array according to Equation (9). An additional power surplus of 20-30% is added to the  $S_{PV}$  while sizing the inverter system so as to prevent from working below the rated efficiency.

$$S_{INV} = \frac{R_p}{P_f} \quad (9)$$

where:

$S_{INV}$  is the system inverter,  $R_p$  is the real power ( $R_p$  is equal to 1.3 of total wattage of all the appliance) and  $P_f$  is the power factor (power factor of 0.8 is adopted in this study for efficiency of the system).

#### f) Sizing of the Generator and Battery of the System

The capacity of the battery used was determined using Equation (10) and the battery load in kW was given in Equation (11). The generator size ( $G_{SIZ}$ ) was determined based on the total load (Loads of all appliance + battery loads) using Equation (12).

$$B_{CAP} = \frac{E_{TPV}}{B_{DD} \times N_V} \times N_D \quad (10)$$

$$BL = (N_B \times V \times A) \times 10^{-3} \quad (11)$$

$$G_{SIZ} = \frac{TL}{BL} \quad (12)$$

where:-

$B_{CAP}$  is the battery capacity,  $B_{DD}$  is the depth of discharge;  $N_D$  is the number of days used;  $N_V$  is the nominal voltage;  $BL$  is the battery load;  $N_B$  is the number of batteries;  $V$  is the

battery voltage;  $A$  is the charging current of the battery and  $TL$  is the total load.

#### g) Sizing of the Solar Charger Controller ( $S_{SCC}$ )

The solar charger controller is rated in-line with the amperage and voltage capacities of the solar PV arrays and batteries. It was determined using Equation (13)

$$S_{SCC} = I_{SC} \times M_{par} \times SF \quad (13)$$

where:

$I_{SC}$  is the short circuit current of the PV panel;  $M_{par}$  is the modules arranged in parallel and  $SF$  is the safety factor.

### 3. RESULT AND DISCUSSION

#### 3.1 Arogo Community Electrical Energy Demand

The total electrical energy demand of the study area based on the information on average power consumption of the appliances and average hours of usage is shown in Table 1. The total power rating of the appliances in all the business outlets covered were computed as 355.228 kW and the total energy demand all the outlets over a specified period of average hours per day was estimated to be 1894.844 kWh with a power factor of 0.8 and 15% tolerance of the maximum load [2].

**Table 1: Table1: Energy Demand for Arogbo Community.**

| S/N  | Facilities/Appliances (F/A) Captured | Total Quantity of each F/A | Number of Outlets | Average Power Rating ( $P_R$ ) of F/A in (Watt) | Average Hour Usage per day $h_D$ , (h) | Total power Rating of F/A. $P_A = P_R \times \text{Qty}$ , in (Watt) | Power Need per Day. $P_D = P_A \times X_n$ (Wh) |
|--|--------------------------------------|----------------------------|-------------------|---|--|--|---|
| 1  | T LCD/LED/Plasma                     | 60                         | 60                | 40  | 8                                      | 2400   |   |
|  | v B/W & Coloured                     | 90                         | 90                | 85  | 8                                      | 7650   | 80400   |
| 2  | DSTv                                 | 65                         | 65                | 25  | 8                                      | 1625   | 130000  |
| 3  | Startime                             | 85                         | 85                | 24  | 8                                      | 2040   | 16320   |
| 4  | Air Conditioner                      | 10                         | 10                | 1010  | 3                                      | 10100  | 30300   |
| 5  | Refrigerator                         | 130                        | 92                | 100   | 8                                      | 13000  | 104000  |
| 6  | Deep Freezer                         | 70                         | 70                | 220   | 10                                     | 15400  | 154000  |
| 7  | Sound System                         | 150                        | 150               | 95  | 10                                     | 14250  | 142500  |
| 8  | Single LED Bulb                      | 300                        | 150               | 10  | 8                                      | 3000   | 24000   |
|  | 40W Build                            | 300                        | 150               | 40  | 8                                      | 1200   | 9600  |
| 9  | Ceiling Fan                          | 200                        | 150               | 75  | 8                                      | 15000  | 120000  |
| 10   | Standing Fan                         | 75                         | 50                | 60  | 8                                      | 4500   | 28000   |
| 14   | Electric Stove                       | 27                         | 18                | 1000  | 2                                      | 27000  | 54000   |
| 16   | Security Light                       | 400                        | 150               | 10  | 11                                     | 4000   | 44000   |
| 17   | Play Station Games                   | 18                         | 10                | 85  | 4                                      | 1530   | 6120  |
| 18   | Phone Charger                        | 300                        | 150               | 5   | 5                                      | 1500   | 7500  |
| 19   | Water Heater                         | 38                         | 25                | 1200  | 0.5                                    | 45600  | 22800   |
| 20   | Transistor Radio                     | 150                        | 150               | 6   | 8                                      | 900  | 7200  |
| 21   | Rechargeable Light                   | 70                         | 60                | 5   | 2                                      | 350  | 750   |
| 22   | DVD Player                           | 150                        | 150               | 35  | 6                                      | 5250   | 31500   |
| 23   | Document Printer                     | 70                         | 50                | 300   | 6                                      | 21000  | 126000  |
| 24   | Photocopy Machine                    | 120                        | 50                | 630   | 6                                      | 75600  | 453600  |
| 25   | Laptop                               | 100                        | 90                | 45  | 4                                      | 4500   | 18000   |
| 26   | Laminating Machine                   | 13                         | 7                 | 450   | 0.5                                    | 5850   | 2925  |
| 27   | Document Scanner                     | 68                         | 54                | 35  | 2                                      | 2380   | 4760  |
| 28   | Desktop PC                           | 110                        | 50                | 120   | 8                                      | 13200  | 105600  |
| 29   | UPS                                  | 60                         | 26                | 240   | 2                                      | 14400  | 28800   |
| 30   | WIFI – Router                        | 18                         | 11                | 6   | 8                                      | 108  | 864   |
| 31   | Hair Clipper                         | 300                        | 60                | 10  | 8                                      | 3000   | 24000   |
| 32   | Barbing Tools Sterilizer             | 9                          | 9                 | 20  | 8                                      | 180  | 1440  |
| 133  | Towel Heater                         | 4                          | 4                 | 60  | 6                                      | 240  | 1440  |
| 34   | Hair Diffuser                        | 14                         | 12                | 260   | 3                                      | 3640   | 10920   |
| 35   | Hair Curling Iron                    | 11                         | 7                 | 85  | 3                                      | 935  | 2805  |
| 36   | Hair Hot Roller                      | 8                          | 8                 | 300   | 3                                      | 2400   | 7200  |
| 37   | Electric Hair Blower                 | 8                          | 6                 | 1500  | 3                                      | 12000  | 36000   |
| 38   | Electrical Hand Hair Dryer           | 15                         | 12                | 1300  | 3                                      | 19500  | 58500   |
| Total Energy Demand for 150 Business Outlets in Watts and Watts-hour |                                      |                            |                   |   |  | 355,228  | 1,894,844                                       |
| Total Energy Demand for 150 Business Outlets in kW and kWh           |                                      |                            |                   |   |  | 355.228  | 1894.844  |
| Total Number of Appliances Captured                                  |                                      |                            |                   |   |  | 3,396  |   |

### 3.2 Average Losses in the Design of the PV system

The average losses in the PV system designed occurred most at the battery and inverter as shown in Table 2. The least losses occurred from the wiring.

**Table 2: Average Losses in the System Design**

| Losses             | PLPV | PLH | PLD | PLW | PLI | PLB |
|--------------------|------|-----|-----|-----|-----|-----|
| Average Values (%) | 2    | 5   | 2   | 1   | 10  | 15  |
| TOTAL Losses (%)   | 35   |     |     |     |     |     |

### 3.3 Typical Barbing Salon Shop Energy Demand

The total power and energy consumption per day for all the eight appliances in the barbing salon

shop considered is shown in Table 3. They were computed as 0.136 kW and 0.938 kWh respectively.

**Table 3: Barbing Salon Energy Demand**

| S/N   | Facilities/Appliances (F/A) Captured | Total Quantity of each F/A | Average Power Rating ( $P_R$ ) of F/A in (Watt) | Average Hour Usage per day $h_D$ , (h) | Total power Rating of F/A. $P_A = P_R \times Qty$ , in (Watt) | Power Supply per Day. $P_D = P_A \times h_D$ , in (Wh) |
|---|--------------------------------------|----------------------------|---|--|---|--|
| 1   | Clipper                              | 2                          | 10  | 8                                      | 20  | 160  |
| 2   | Tools Sterilizer                     | 1                          | 20  | 8                                      | 20  | 160  |
| 3   | Single LED Bulb                      | 3                          | 10  | 7                                      | 30  | 210  |
| 4   | Sanding Fan                          | 1                          | 60  | 6                                      | 60  | 360  |
| 5   | Transistor Radio                     | 1                          | 6   | 8                                      | 6   | 48   |
| <b>Total Power Requirement in Watts and Watts-hour</b>  |                                      |                            |   |  | <b>136</b>  | <b>938.0</b>   |
| <b>Total Energy Requirement in kW and kWh</b>           |                                      |                            |   |  | <b>0.136</b>  | <b>0.938</b>   |
| <b>Total Number of Facilities/Appliances Considered</b> |                                      |                            |   |  | <b>8</b>  |  |

The stand-alone PV hybrid energy system for the barbing salon was designed based on the energy information on Table 3. It was established that a single barbing salon shop required at least one (1)

solar panel rated 300 W at voltage rating of 24 V, one (1) battery of 100AH at 24 V, a 0.22kVA, a charge controller rated 12 A and a 0.47 kVA generator as shown in Table 4.

**Table 4 Summary of the Design of Stand-alone PV System for Barbing Salon Shop**

| Sizing of the System                        | Equations  | Values Obtained                       |
|---|--|---------------------------------------|
| Power consumption per day                   | $S_p = \sum_{j=1}^{j=5} (P_A)$                           | 0.938 kWh                             |
| Solar PV Power requirement per day          | $E_{TPV} = \sum_{j=1}^{j=5} (P_A) + PL$                  | 1.266 kWh                             |
| Sizing of the PV Arrays                     | $S_{PV} = \frac{E_{TPV}}{RH} \times E_F$                 | 0.317 kW                              |
| Arrays Area                                 | $AM = Spv \times 100ft^2$                                | 3 m <sup>2</sup>                      |
| Panel generation factor                     | $PGF = S_{irrad} \times T_{CF-PV}$                       | 4.1                                   |
| Total watt-peak of PV panel capacity needed | $P_{Wp} = \frac{E_{TPV}}{PGF}$                           | 309 Wp                                |
| Total number of PV panels needed            | $N_p = \frac{P_{Wp}}{P_{max}}$                           | 1.06 ≈ 1 solar PV Module              |
| Inverter sizing                             | $S_{INV} = \frac{RP}{P_F}$                               | 0.22 kVA                              |
| Sizing of Battery                           | $B_{CAP} = \frac{E_{TPV}}{B_{DD} \times N_V} \times N_D$ | 105AH (1 battery being a 100AH @ 24V) |
| Solar charge controller sizing              | $S_{SCC} = I_{SC} \times M_{par} \times SF$              | 12 Amperes.                           |
| Generator Sizing                            | $G_{SIZ} = \frac{TL}{BL}$                                | 0.47 ≈ 1 kVA @ 0.8 PF                 |

The schematic diagram of the Stand-alone PV system designed for the barbing salon shop in

Arogbo community is shown in Figure 3

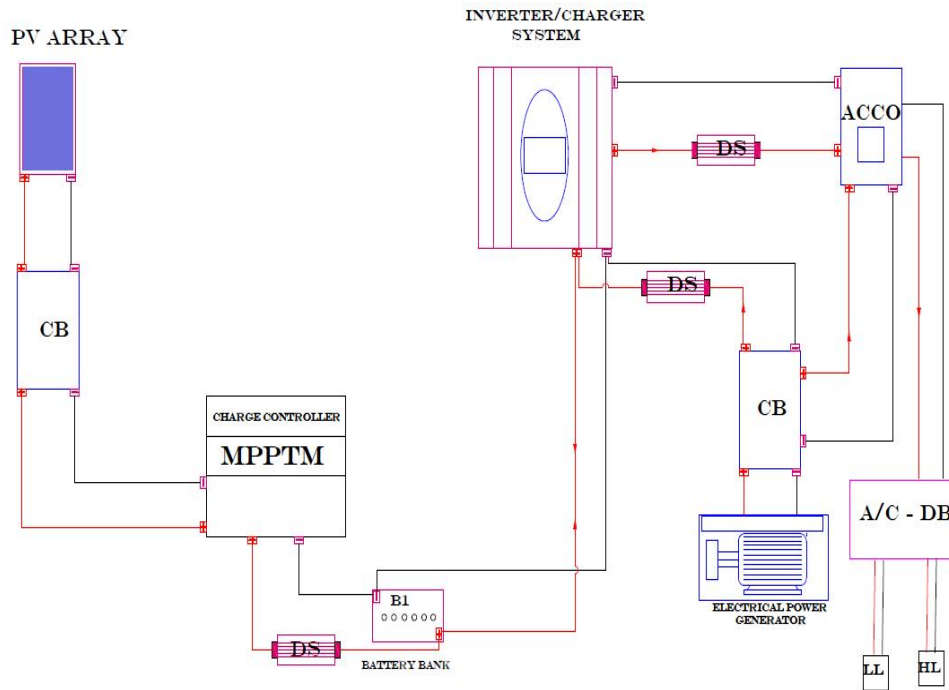

Figure 3: A Stand-alone PV Hybrid Energy System for a typical Barbing Salon

### 3.4 Typical Computer Centre Shop Energy Demand

The total power and energy consumption per day for all the eleven appliances in the computer

centre shop considered is shown in Table 5. They were computed as 2.035 kW and 9.045 kWh respectively.

Table 5: Computer Centre Shop Energy Demand

| S/N   | Facilities/Appliances (F/A) Captured | Total Quantity of each F/A | Average Power Rating ( $P_R$ ) of F/A in (Watt) | Average Hour Usage per day $h_D$ , (h) | Total power Rating of F/A. $P_A = P_R \times Qty$ , in (Watt) | Power Supply per Day. $P_D = P_A \times h_D$ , in (Wh) |
|---|--------------------------------------|----------------------------|---|--|---|--|
| 1   | Laptop                               | 1                          | 45  | 4                                      | 45  | 180  |
| 2   | Printer                              | 1                          | 300   | 6                                      | 300   | 1800   |
| 3   | Photocopy Machine                    | 1                          | 630   | 6                                      | 630   | 3780   |
| 4   | Document Scanner                     | 1                          | 35  | 2                                      | 35  | 70   |
| 5   | Desktop PC                           | 2                          | 120   | 8                                      | 240   | 1920   |
| 6   | Laminating Machine                   | 1                          | 450   | 0.5                                    | 450   | 225  |
| 7   | UPS                                  | 1                          | 240   | 2                                      | 240   | 480  |
| 8   | Single LED Bulb                      | 2                          | 10  | 7                                      | 20  | 140  |
| 9   | Standing Fan                         | 1                          | 75  | 6                                      | 75  | 450  |
| <b>Total Power Requirement in Watts and Watts-hour</b>  |                                      |                            |   |  | <b>2035</b>   | <b>9045</b>  |
| <b>Total Energy Requirement in kW and kWh</b>           |                                      |                            |   |  | <b>2.035</b>  | <b>9.045</b>   |
| <b>Total Number of Facilities/Appliances Considered</b> |                                      |                            |   |  |   | <b>11</b>  |

Table 6 showed the summary of the analysis of the stand-alone PV system designed for a typical computer centre in Arogbo community. It was established from the analysis that a single computer centre required at least six (6) solar

panels rated 500 W at voltage rating of 48 V each, four (4) batteries each being 150 AH at 12 V, a 4 kVA inverter, a charge controller rated 82 Amps, and a 4 kVA generator to generate electricity needed to power the appliances in the shop.

**Table 6: Summary of the Design Analysis of Stand-alone PV System for Computer Centre Shop Sizing of the System**

| Sizing of the System                        | Equations  | Values Obtained                               |
|---|--|---|
| Power consumption per day                   | $S_P = \sum_{j=1}^{j=9} (P_A)$                           | 9.045 kWh                                     |
| Solar PV Power requirement per day          | $E_{TPV} = \sum_{j=1}^{j=9} (P_A) + PL$                  | 12.211 kWh                                    |
| Sizing of the PV Arrays                     | $S_{PV} = \frac{E_{TPV}}{RH} \times E_F$                 | 3.053 kW                                      |
| Arrays Area                                 | $AM = Spv \times 100ft^2$                                | 28.4 m <sup>2</sup>                           |
| Panel generation factor                     | $PGF = S_{irrad} \times T_{CF-PV}$                       | 4.1   |
| Total watt-peak of PV panel capacity needed | $P_{WP} = \frac{E_{TPV}}{PGF}$                           | 2978 Wp                                       |
| Total number of PV panels needed            | $N_P = \frac{P_{WP}}{P_{max}}$                           | 5.96 ≈ 6 solar PV modules                     |
| Inverter sizing                             | $S_{INV} = \frac{RP}{PF}$                                | 3.31 ≈ 4 kVA                                  |
| Sizing of Battery                           | $B_{CAP} = \frac{E_{TPV}}{B_{DD} \times N_V} \times N_D$ | 508.8 AH (4 batteries each being 12V @ 150AH) |
| Solar charge controller sizing              | $S_{SCC} = I_{SC} \times M_{par} \times SF$              | 81.525 ≈ 82 Amperes                           |
| Generator Sizing                            | $G_{SIZ} = \frac{TL}{BL}$                                | 3.54 ≈ 4 kVA @ 0.8 PF                         |

The schematic diagram of the designed stand-alone PV hybrid energy system for the computer

Centre shop in Arogbo community is shown in Figure 4

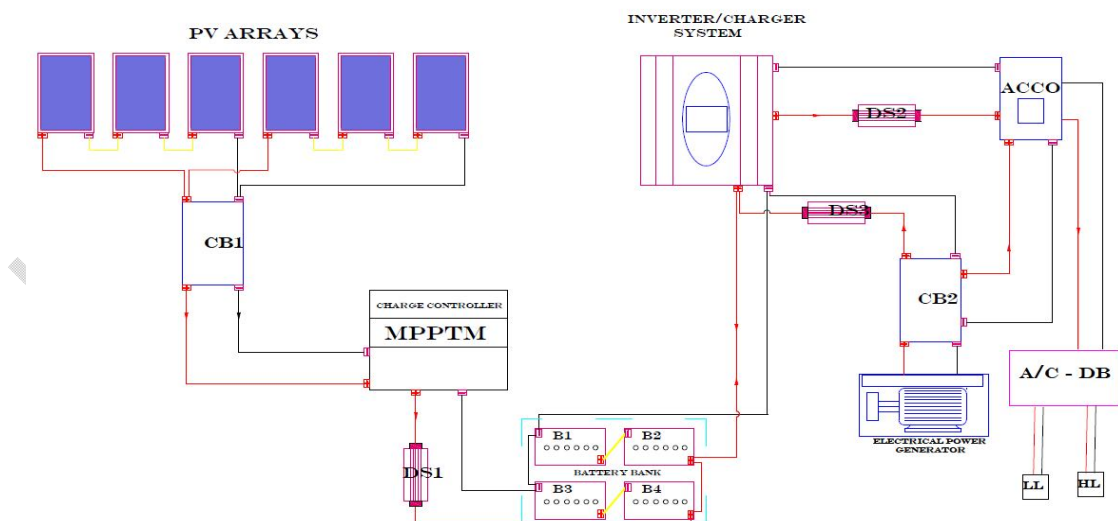

**Figure 4: A Stand-alone PV Hybrid Energy System for a Typical Computer Centre**  
**3.5 Typical Hairdressing Salon Shop Energy Demand**

The total power and energy consumption per day for all the seven appliances in the hairdressing shop considered is shown in Table 7. They were computed as 3.49 kW and 10.87 kWh respectively. The summary of the analysis of the Stand-alone PV hybrid energy system designed

based on the energy information on Table 7 for an hairdressing salon shop is shown on Table 8. It was established that it requires a minimum of seven (7) solar panels rated 500 W at voltage rating of 48 V each, four batteries each being 150AH at 12 V, a 6 kVA inverter, a charge controller rated 101 A and a 6 kVA generator

**Table 7: Hairdressing Salon Shop Energy Demand**

| S/N  | Facilities/<br>Appliances (F/A)<br>Captured | Total<br>Quantity of<br>each F/A | Average<br>Power Rating<br>(P <sub>R</sub> ) of F/A in<br>(Watt) | Average Hour<br>Usage per day<br>h <sub>D</sub> , (h) | Total power<br>Rating of F/A.<br>P <sub>A</sub> = P <sub>R</sub> X Qty, in<br>(Watt) | Power Supply per<br>Day. P <sub>D</sub> =P <sub>A</sub> X h <sub>D</sub> , in<br>(Wh) |
|--|---|----------------------------------|--|---|--|---|
| 1  | Tower Heater                                | 1                                | 60   | 6   | 60   | 360   |
| 2  | Hair Diffuser                               | 1                                | 260  | 3   | 260  | 780   |
| 3  | Hair Hot Roller                             | 1                                | 300  | 3   | 300  | 900   |
| 4  | Standing Fan                                | 1                                | 60   | 6   | 60   | 360   |
| 5  | Electric Hair<br>Blower                     | 1                                | 1300   | 3   | 1300   | 3900  |
| 6  | Electric Hair<br>Dryer                      | 1                                | 1500   | 3   | 1500   | 4500  |
| 7  | Single LED Bulb                             | 1                                | 10   | 7   | 10   | 70  |
| <b>Total Power Requirement in Watts and Watts-hour</b> |   |                                  |  |   | <b>3,490.0</b>   | <b>10,870.0</b>   |
| <b>Total Energy Requirement in kW and kWh</b>          |   |                                  |  |   | <b>3.49</b>  | <b>10.87</b>  |
| <b>Total Number of Appliances Considered</b>           |   |                                  |  |   | <b>7</b>   |   |

**Table 8: Summary of the Design Analysis of Stand-alone PV System for a Hairdressing shop**

| Sizing of the System                        | Equations  | Values Obtained                             |
|---|--|---|
| Power consumption per day                   | $S_n = \sum_{j=1}^{j=7}(P_A)$                            | 10.87 kWh                                   |
| Solar PV Power requirement per day          | $E_{TPV} = \sum_{j=1}^{j=7}(P_A) + PL$                   | 14.67 kWh                                   |
| Sizing of the PV Arrays                     | $S_{PV} = \frac{E_{TPV}}{RH} \times E_F$                 | 3.66 kW                                     |
| Arrays Area                                 | $AM = Spv \times 100ft^2$                                | 34 m <sup>2</sup>                           |
| Panel generation factor                     | $PGF = S_{irrad} \times T_{CF-PV}$                       | 4.1   |
| Total watt-peak of PV panel capacity needed | $P_{Wp} = \frac{E_{TPV}}{PGF}$                           | 3578 Wp                                     |
| Total number of PV panels needed            | $N_p = \frac{P_{Wp}}{P_{max}}$                           | 7.2 ≈ 7 solar PV modules                    |
| Inverter sizing                             | $S_{INV} = \frac{RP}{PF}$                                | 5.67 ≈ 6 kVA                                |
| Sizing of Battery                           | $B_{CAP} = \frac{E_{TPV}}{B_{DD} \times N_V} \times N_D$ | 611AH (4 batteries each being 12 V @ 150AH) |
| Solar charge controller sizing              | $S_{SCC} = I_{SC} \times M_{par} \times SF$              | 95.11 ≈ 95 Amperes.                         |
| Generator Sizing                            | $G_{SIZ} = \frac{TL}{BL}$                                | 6.1 ≈ 6 kVA @ 0.8 PF                        |

The schematic diagram of the stand-alone PV hybrid energy system designed for a typical

hairdressing salon shop in Arogbo Community is shown in Figure 5.

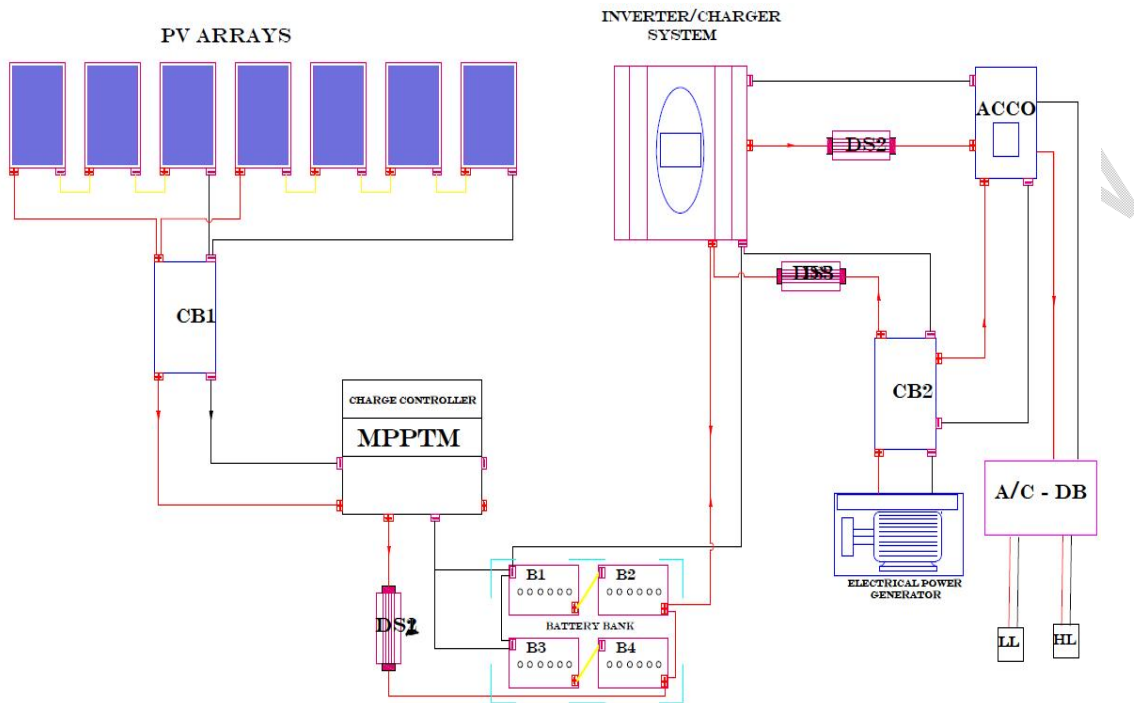

Figure 5: A Stand-alone PV Hybrid Energy System for a Typical Hairdressing Shop

### 3.5 Cost Implication

The cost of the various components designed and selected was based on the exchange rate of four hundred Nigeria Naira (₦400.00) to one United State Dollar (\$1.00). The summary of the

estimated costs is shown on Table 9. This cost was based on unit purchasing of components and may vary at implementation the state of economy and bulk purchase.

Table: 9 Summary of the Cost Implication

| S/No | Particular           | Cost in Naira (₦) | Cost in Dollar (\$) |
|------|----------------------|-------------------|---------------------|
| 1    | Barbing Salon Shop   | 354,500.00        | 866.25              |
| 2    | Computer Centre Shop | 1,972,500.00      | 4,931.25            |
| 3    | Hairdressing Shop    | 2,494,000.00      | 6,235.00            |

### 4. CONCLUSION

A stand-alone photovoltaic energy system has been designed for small-scale business outlets in rural area in this paper. The small-scale business outlets considered in the community are Barbing Salon, Computer Centre shop and hairdressing shops and energy audit was carried out for all the appliances in the business outlets. The following conclusions were drawn:

a. The total power rating for all the appliances collated was estimated to be 355.228 kW

and total electrical energy demands for the outlets over a specified period of 8 hours per day with power factor of 0.8 and 15% tolerance was estimated as 1894.844 kWh

- The total PV energy required for a typical Barbing Salon was estimated as 1.266 kWh (1.58 KVA) at a cost of ₦354,500.00
- The total PV energy required for a typical Computer Centre was estimated as 12.211 kWh (15.26 KVA) at a cost of ₦1,972,500.00

- d. The total PV energy required for a typical hairdressing salon shop was estimated as 14.67 kWh (18.33KVA) at a cost of ₦2,494,000.00

The study showed that electricity can be generated and supplied to rural areas through a Stand-alone photovoltaic energy system to power small-scale business outlets at affordable prices.

## REFERENCES

1. Akinola, A. O. (2016) "Renewable Energy Development for Sustainable National Growth" Paper presented at the 2016 Annual Conference of the School of Engineering and Engineering Technology (SEET), the Federal University of Technology, Akure. Hill Top Auditorium; The Federal University of Technology, Akure. (16th – 19th August, 2016) Pp. 123 - 130
2. Akinola, A. O., Ephenus, M. D., Akinsade, A., and Eiche, J. F. (2022): Design of Off-Grid Hybrid Energy for Residential Buildings in Rural Areas: A case study of Arogbo Community in Ondo State. *Journal of Energy Research and Reviews*: 11(5): 1-15
3. Mogaji, T. S., Akinsade, A. and Akintunde, M. A. (2019):" Pyrolysis of Sugarcane Baggasse for Bio-oil Production". *Journal of Engineering and Engineering Technology (FUTAJET)*. 13 (2): 150-157
4. Chaichan, M. T., Kazem, H. A., Abid, T. A., (2016): "The Environmental Impact of Transportation in Baghdad, Iraq". *Environment, Development and Sustainability*, 18 (6), DOI:10.1007/s10668-016-9900-x.
5. Mahmood, A. L. (2019): "Design and simulation of stand-alone PV system for electronic and communications engineering department laboratories in Al-Nahrain University," EAI Endorsed Transactions on Energy Web. 6(21), 1-8. Doi: 10.4108/eai.13-7-2018.156438.
6. United State Agency for International Development (USAID), (2018): Power Africa. Nigeria Fact Sheet: [www.usaid.gov](http://www.usaid.gov)
7. Al-Shamani, A. N., Abada, H. H. and Faisal, M. D. (2020): "Stand-Alone Solar Power Systems Designed for Office" *Journal of Xi'an University of Architecture and Technology*, Vol. xii, Issue iii, 2629 – 2634
8. Adejuyigbe, S. B., Bolaji, B. O., Olanipekun, M. U. and Adu, M. R. (2013): Development of a solar photovoltaic power system to generate electricity for office appliances. *Engineering Journal*, 17(1); 29-39
9. Khare, V., Nema, S. and Baredar, P. (2016): "Solar-wind hybrid renewable energy system: A review. *Renewable and Sustainable Energy Reviews*, Volume 58, Pp. 23 - 33
10. Mei, S. N., and Chee, W. T. (2012): Assessment of Economic Viability for PV/wind/diesel hybrid energy system in Southern Peninsular Malaysia. *Renewable Sustainable Energy Review*. 16(1): 634-647
11. Taher, M., Nahed, G., and Sassi, B. N. (2016): "Assessment viability for hybrid energy system (PV/wind/diesel) with storage in the Northernmost city in Africa. Bizerte, Tunisia". *Renewable and Sustainable Energy Reviews*. 56(2), 1639-1652
12. Oni, J. O and Bolaji, B. O. (2011): Development of a Universal DC power supply using solar photovoltaic utility and battery power sources. *Journal of Energy in Southern African*. 22(1): 12-17
13. Ali, Z.H., Ahmed, A. K., Saeed, A. T (2018): "Modeling solar modules performance under temperature and solar radiation of western Iraq" *International Journal of Power Electronics and Drive System (IJPEDS)*, 9(4), 1842-1850
14. Guda, H. A and Aliyu U. O. (2015) "Design of a Stand-Alone Photovoltaic System for a Residence in Bauchi". *International Journal of Engineering and Technology*, 5(1): 34-44.
15. Saleh. U.A, Y.S. Haruna, and F.I Onuigbo. (2015): "Design and Procedure for Stand-Alone Photovoltaic Power

- System for Ozone Monitor Laboratory at Anyigba, North Central Nigeria” *International Journal of Engineering Science and Innovative Technology*, 4(6): 41-52.
16. Chin, S., Young., A and Kenneth, K., (2010): Maximum Power Point Tracking for PV Array under Partially Shaded Conditions. Third International Conference on Computational Intelligence Community System and Networks, (CICSYN), Bali, Indonesia, 26-28
  17. Mahasin, S. (2012): “Explained: Solar PV System for Home” Retrieved from <https://shackmohasinwordpress.com/explained-solar-pv-system-for-home/> on 14th October, 2022
  18. National Population Census, (2006): Report of Nigeria’s National Population Commission on the 2006 Census; (Online), Cited 2022, April. Available: <https://www.population.gov.ng/>
  19. Al-Tarabsheh A, Akmal M, Ghazal M. (2017): Series Connected Photovoltaic Cells –Modelling and Analysis. *Sustainability*. 9(3):371-376
  20. Melodi, A. O. Famakin ,S. R. (2011): Assessment of Solar PV-Grid Parity in Akure, South West Nigeria. *Journal of Emerging Trends in Engineering and Applied Sciences (JETEAS)*. 2(3):531–536.

UNDER PEER REVIEW