

HANDLINK: A Dexterous Robotic Hand Exoskeleton controlled by Motor Imagery (MI) to Assist Individuals with Upper Body Paralysis

Abstract

Introduction: Over 5.6 million stroke survivors in the United States experience hemiparesis of the upper limb. Assistive devices are used to help regain upper limb functionality for affected individuals; however, existing devices are bulky, costly, and lack adaptability. The objective of this pilot study was to test performance of a newly developed hand exoskeleton on a sample of individuals with hand impairment.

Methods: A hand exoskeleton was developed comprising of a novel linkage system with three four-bar linkages structures set-up in a series and a novel algorithm that finds optimal EEG channels, through Common Spatial Pattern (CSP) Recognition, and classifies them with a stacked LDA-SVM classifier. Functionality of the novel hand exoskeleton was tested by examining performance across a battery of hand mobility assessments among individuals in the experimental group with hand impairment (n=10) compared to controls (n=10).

Results: Better performance was observed for the experimental group with the exoskeleton compared to without the exoskeleton across function, grip force, and range of motion measures. There was no statistical difference in mean performance of the experimental group with the exoskeleton compared to the control group for most measures, indicating that functionality with the exoskeleton is comparable to a healthy hand. The LDA-SVM classifier resulted in an 88% accuracy in classifying which finger the user intends to move with minimal latency as a result of its computational efficiency.

Conclusions: Findings suggest HANDLINK was effective in improving function, grip force, and range of motion among hand-impaired individuals. The HANDLINK, and its complementary stacked SVM-LDA classification algorithm, works as a viable solution for a fully adaptable and cost-effective assistive hand aide for individuals with paraplegia.

Introduction

Currently, there are nearly 7 million stroke survivors in the United States [1]. Eighty percent of stroke patients experience hemiparesis of the contralateral upper limb acutely and more than 40% chronically [2]. Though some individuals can regain functionality, approximately 65% of affected individuals remain paralyzed or have significant impairments to daily movement [3].

Hand function is crucial for maintaining independence during daily life activities [4]. Unfortunately, this is the most challenging impairment to recover; in fact, just 5% of the stroke survivors with hemiparesis fully recover hand functionality. The most conspicuous symptoms of a hemiparetic hand include weakness of specific muscles, lack of mobility, incorrect timing of movements, abnormal muscular synergies, loss of inter-joint coordination, loss of sensation, reduced range of movement (ROM), reduced finger independency, closed position, and incapability to maintain a constant grip force etc. Motivated by the goal to help or enhance arm function in patients with hemiparesis and other upper-limb motor impairment, a plethora of studies addressing assistive technologies and hand exoskeletons have been published [5, 6].

Assistive technology, an umbrella term for assistive, adaptative, and rehabilitative devices for people with disabilities and the elderly, is used to help a person with a disability perform a certain task or multiple tasks. An exoskeleton is an active mechanical device used for either therapeutic or assistive intent, is worn by an operator, fits closely to their body, and works in concert with the operator's movement [7].

Currently, there are three main categories of assistive devices for upper body paraplegics: silicon assistive attachments, tension-based exoskeletons, and pneumatic-soft exoskeletons [8-10].

Silicon assistive attachments are aides placed on household objects that make them easier to be used and maneuvered by individuals with upper-body paralysis [11]. Silicon is chosen because it is a flexible yet durable material that is inexpensive to manufacture. Although silicon is a versatile substance, it limits the user to only interacting with objects with specified assistive attachments. Furthermore, some assistive aide attachments adopt the philosophy of a one-size-fits-all product, limiting the availability of customizable grips in the assistive device market.

Exoskeleton-based assistive devices are placed directly onto the user's hand and are actuated through different mechanisms. There are both tension-based exoskeletons and pneumatic-soft exoskeletons that operate to increase the mobility of users. Tension-based exoskeletons emulate the antagonist-antagonist joint actuation of the human hand using a cable-based actuation mechanism. [12]. Though it presents a feasible prosthetic design, it is less desirable for exoskeletons for two reasons. First, they cannot scale to the entire hand. For example, the HANDEXOS prototype [12] only accommodates one fully actuated finger partially because the actuator for a single finger takes up the entire surface area of the wrist. Similarly, the Maestro robotic exoskeleton [13] highlights the need for the device to be more compact. The second limitation is related to the practical functionality of a device with an actuator for all five fingers. The average weight of one finger using a traditional tension-based exoskeleton is about 115g [12]; actuating all fingers would mean creating an excessively heavy device.

Pneumatic-soft exoskeletons, the other type of exoskeleton-based assistive device, is typically comprised of five soft-actuators on the dorsal side of each finger. These actuators are either connected to a single or multiple air sources. For example, the "ExoGlove" is made with a two-part mold, the bottom part creating pneumatic channels inside the actuator that inflates upon pressurization, and the upper part, acting as a feature mold to impose variable stiffness in different areas that can change the shape [14]. Pneumatic-soft exoskeletons work in a circular motion, thus not conforming to the shape of the finger [15]. This results in inaccurate joint kinematics.

Furthermore, the soft robotic hand exoskeletons with a pneumatic actuator are bulky and heavy due to the numerous required accessories, including a compressor, storage tank, valves, and transport air tubes [16]. For example, the Harvard University hand exoskeleton [17] can only operate continuously for three hours and limits user movement due to bulky device accessories such as voltage regulators and valve controls. For these reasons, soft robotic hand exoskeletons with pneumatic actuators are recommended for remote actuation or are constrained to users with wheelchairs to store all the accessories [18].

Exoskeletons provide functionality for the user using intention-sensing methods. These are methods that recognize and interpret electrical signals given off by the user's brain when trying to perform a task and dictate movement through the exoskeleton. Intention sensing

methods for hand exoskeletons can be divided into two main types: surface electromyography (sEMG)-controlled, and electroencephalography (EEG)-controlled.

An sEMG-driven exoskeleton uses myoelectric signals collected through electrodes placed on the user's forearm. The sEMG is a type of AC voltage; however, the exact measurements will change based on the individual and the exact muscle being measured [19]. It is common for the electrodes of the sEMG to be placed on the antagonist muscles of the forearm to pick up the best signals. There are limitations to this type of intention-sensing method. First, the approach to capture electrical signals is not sensitive enough to distinguish the movements between fingers, leading to the wrong type of movement or grasp [20]. This is clearly shown in the Maestro hand, which can only do three poses due to the sEMG's inability to detect muscles corresponding to individual finger movements [21]. Further, EMG-driven exoskeletons do not act as a practical intention sensing methods for assistive hand exoskeletons for more severe cases of paresis, because these users often cannot generate muscle activity until more advanced stages of therapy [20].

The alternative intention-sensing method is an electroencephalography-based system. An electroencephalographic hand exoskeleton is driven by brain signals collected from a group of electrodes placed on the user's head in a specific formation. The electrodes capture brain signals and transfer them to the exoskeleton using brain-computer interphase (BCI) technology. The most common BCI-based hand exoskeleton is attention based. In this scenario, the intensity of a user's attention acts like a switch to start and end the grasping motion of the user. More sophisticated BCI approaches attempt to classify motor imagery, the conscious access to the content of the intention of a movement. [22,23]. Generating a mental image of a movement is typically followed by a discharge of neural activity to activate the target muscles [25]. In most research regarding motor imagery, the classifier has both a filter and a mathematically based classifier. For example, some EEG-based devices use a Finite Impulse Response (FIR) filter with a Bayesian classifier based on EEG covariance matrices[26]. Significant limitations to EEG-driven exoskeletons include the cost and feasibility of the machine. There are few machines that are completely portable, but they have fewer input channels when reading data from the user's brain.

In summary, studies on exoskeletons result in bulky, costly, and inefficient prototypes. No adaptable and universal aides have been reported that allow stroke patients to maneuver unmodified objects. This paper presents the design of an adaptable hand exoskeleton that allows individuals with hand paralysis to manipulate real-world objects. This hand exoskeleton is controlled through a non-invasive EEG machine, with all processing occurring in real-time with minimal latency. The performance of the exoskeleton was measured using tests of overall hand function, range of motion, and grip force.

Methods

The Device

This study reports results of testing on a novel exoskeleton device. The HANDLINK is a linkage-based hand exoskeleton, comprised of a battery unit and microcontroller. The linkage structure is made up of three four-bar linkages arranged in series. This structure is characterized by a single-linear actuator that is used to move each finger, allowing each finger to be fully actuated while still having the entire hand-exoskeleton remain lightweight (12 oz). The linkage structure of the exoskeleton was created through an additive manufacturing process and is made up of 1.75 ± 2 mm Polylactic Acid (PLA) Filament (Figure 1).

Reference to Figure 1 Here.

All intention signals for this device are received by an OpenBCI 16-channel EEG headset. The exoskeleton provides 2D-movement with millimeter level accuracy, without the need for external sensors. The three four-bar linkage design allows the microcontroller (Arduino) attached to the hand exoskeleton to mathematically calculate the exact angle of each of the joints without any sensors. This is shown with the kinematic model, derived the vector-loop method, of

:

$$ae^{j\theta_1} + be^{j\theta_2} - ce^{j\theta_3} - d = 0 \quad (1)$$

$$de^{j\theta_4} + fe^{j\theta_5} - ge^{j\theta_6} - h = 0 \quad (2)$$

$$he^{j\theta_7} + ke^{j\theta_8} - le^{j\theta_9} - m = 0 \quad (3)$$

where:

a, b, c, d, f, g, h, k, l, m = length of linkages

$\theta_1, \theta_2, \theta_3, \theta_4, \theta_5, \theta_6, \theta_7, \theta_8, \theta_9$ = interior angles

A. Biomechanical Modeling

The HANDLINK has multiple remote centers of motion (RCM) for each finger. RCM allows for a body to rotate around an axis that is remotely located from the center of the joint. As a result of this unique linkage structure, each four-bar linkage has one RCM. In the HANDLINK, the RCM is in line with the Metacarpophalangeal (MCP), Proximal Interphalangeal (PIP), and Distal Interphalangeal (DIP) joints. This allows for a mechanism that does not interfere with the participants' joints, but still allows for a full range of motion.

B. Finger Mechanism

The HANDLINK exoskeleton uses a novel three four-bar linkage structure set up in a series to achieve full adaptability. Each four-bar linkage has 1 degree of freedom (DOF), and when set up in series it allows for a single linear actuator to move each finger. The entire mechanism and actuation system is situated on the dorsal side of the hand, leaving the palm open to grasp items.

The four-bar linkage is the simplest, and often, most useful mechanism. It has three moving links, and one fixed linkage considered the ground link. For each four-bar linkage, each phalange is considered a ground link; therefore, there is one four bar linkage that corresponds to each phalange. However, the novel aspect of this research is arranging the linkage structures in

series, and the mechanical advantage provided from each to move the next linkage. This allows each finger to only need one actuator and a reduced number of sensors, making the entire hand exoskeleton even more lightweight.

A four-bar linkage converts reciprocal motion to rotary motion (Figure 2). The reciprocal motion is provided from a linear actuator attached to the dorsal side of a hand. A linear actuator is one of the most effective actuators for this innovation as it is compact, lightweight, and cost-effective. Furthermore, it is possible to know the angle of each finger from the encoder in the motor.

Reference Figure 2 Here.

C. Intention Sensing

All intention signals for this device are received by an OpenBCI 16-channel EEG headset. The main board reading all the EEG data input is an OpenBCI's Ganglion Board. However, classification of what finger the user wants to move is done using Amazon Web Services (AWS)'s EC2 Virtual Machine (VM). This decreases processing time due to the VM's computing power; however, it does increase total transfer time as the data must be sent to the cloud, processed, and then the result must be sent back to the Arduino. The data is processed using a band-pass filtering from 7 hz to 30 hz and a Common Spatial Pattern (CSP) algorithm to reduce dimensionality (Figure 3). The data is classified with a novel stacked SVM-LDA classifier.

Participants

The following study procedure was approved by the Alameda County Science and Engineering Fair (ACSEF) IRB. Convenience sampling was used to identify ten individuals with

impaired hand movement. Eligibility criteria included adults (ages 18-85) who had difficulty fully closing or opening their hands due to a self-reported physical condition or disability. Due to the design of the exoskeleton used in the study, only right-hand dominant participants were eligible for the study. The Edinburgh Handedness Inventory (EHI) was used to assess hand dominance. Those with a laterality quotient score above 80% were included. Adults with hand mobility challenges due to self-reported cognitive disabilities and adults that could not understand the interview questions due to either cognitive impairment or language barrier were excluded from the study.

A similar sampling strategy was used to recruit an additional ten individuals from the same facility to serve as controls. Inclusion criteria for the control group were adults (ages 18-85) who self-reported no injuries in the spinal cord or hand, did not report cognitive disabilities, and were right-handed.

No identifying information about the participant was recorded or kept.

Study procedure

Eligible and consenting participants completed a battery of mobility measures. All participants repeated each measure three times, except for the Sollerman Hand Function test which was done once. The experimental group was then fitted with the exoskeleton and asked to repeat the same battery of measures three times.

Hand Function: Participants were asked to perform eight of the most common types of hand grips: pulp pinch, lateral pinch, tripod pinch, five-finger pinch, diagonal volar grip, transverse volar grip, spherical volar grip. These hand grips are considered basic hand movements and used in everyday life [27]. To test each grip, the Sollerman Hand Function Test [28] was used to measure performance across each grip. Participants were scored on 20 items: 8 items measuring pulp pinch, 8 tests measuring lateral, 3 tests measuring the tripod grip, 3 tests measuring five-finger pinch, 2 tests measuring diagonal volar grip, 3 items measuring transverse volar grip, and 1 item measuring the spherical volar grip. The scoring procedure is outlined in

Table 1. Participants' score on each item were summed for a total score representing hand function.

ROM was assessed using a goniometer [29], A dorsal finger goniometer was used to measure the maximum angle each finger joint can move from the origin in the flexion direction, for all joints, and extension direction for the metacarpophalangeal joint. The maximum angles for each joint were recorded and then averaged across each finger, for a total of four averages per individual: a maximum angle value for the flexion of the metacarpophalangeal joint (Joint1), a maximum angle for extension of the metacarpophalangeal joint, a maximum angle for the extension of the interphalangeal joint (Joint 2), and a maximum angle for the extension of the distal interphalangeal joint (Joint 3). Since the thumb only has a metacarpophalangeal and interphalangeal joint, it was not included in the distal interphalangeal average.

Grip Force: Grip force was measured using the CAMRY Digital Hand Dynamometer Grip Strength Measurement Meter [30]. Each patient was asked to fully grip the device to produce a grip force measured in pounds. If the patient could not fully grip the device, their result would be recorded as zero.

Statistical Analysis

All descriptive information about the participants is shown in Table 1. Paired two-sample t-tests were used to compare mean performance across the physical function outcomes for experimental group participants with and without the exoskeleton (Table 2). Unpaired two sample t-tests assuming unequal variance were used to compare the mean performance across the physical function outcomes for experimental group participants with the exoskeleton and the control group. Performance across the three iterations of the ROM and Grip tests for each participant were recorded and averaged across groups. Performance of the Sollerman Hand Function test was directly recorded without any averaging. Results were considered statistically significant when the p-value was less than 0.05.

Results

There were 10 participants in the experimental Group and 10 participants in the control group. The median age of the experimental group is 75.5 while the median age of the control group is 47. The experimental group was tested two times, once without the exoskeleton and once with it.

Average ROM performance across all fingers and joints was poorer for experimental group participants without the exoskeleton aid when compared to ROM with the exoskeleton aid (see Table 3). The mean difference in performance for all joints across all fingers was statistically significant. A statistically significant improvement in the mean performance with the exoskeleton was also observed for Grip Force and the Sollerman hand function test.

Performance of the experimental group with the hand exoskeleton was similar to that of the control group. Average ROM was similar for most of the fingers and joints. The mean difference in performance for all joints across most fingers and joints showed no statistically significant difference between the experimental group with the exoskeleton and the control group. Results from the Grip Force and the Sollerman Hand Function tests similarly showed no statistically significant difference between the two groups.

Discussion

Through this research, we developed a novel hand exoskeleton that allows for an adaptable, cost-effective assistive aide. Pilot testing indicated that the exoskeleton was successful in restoring hand functionality of impaired individuals.

HANDLINK consists of four finger modules, each made up of three four-bar linkages set up in series. By using this novel linkage structure, the hand exoskeleton is fully adaptable, allowing for any individual to wear it. The linkage structure uses a remote center of motion that aligns with each joint of the finger, allowing almost any individual to obtain a full ROM. This hand exoskeleton provides extension/flexion for all four metacarpophalangeal joints and flexion for all four proximal interphalangeal and distal interphalangeal joints.

By allowing this linkage structure to be fully adaptable, it is possible mass produce this hand exoskeleton, while still being cost-effective. The current prototype is 3D-Printed and weighs 12oz with a total production cost of \$206. More than half of this cost came from the purchase of the linear actuators. Yet, the device was robust. The 3D printed structures did not require repair or replacement throughout the testing period.

Aside from the exoskeleton, we have worked on creating two new EEG-Processing algorithms. The first utilizes the Common Spatial Pattern algorithm, a mathematical procedure used in signal processing for separating a multivariate signal into additive subcomponents. We used this algorithm to find the EEG channels with the most activity and only used the signals from those channels as inputs in our stacked SVM-LDA classifier. Through this we can reduce the 16 channel EEG to just 7 channels, greatly increasing the processing speed of the algorithm.

Tables and Figures

Table 1. Scoring Procedure for Sollerman Hand Function Test

0	The patient could not carry out the task
1	The task was partially performed in 60 seconds
2	The task was completed, but with great difficulty, or the task was not carried out with the prescribed hand-grip, or the task was not completed within 40 seconds but within 60 seconds
3	The task was completed, but with slight difficulty, or the task was carried out with the prescribed hand-grip but with slight divergence from normal, or the task was not completed within 20 seconds but within 40 seconds
4	The task was carried out without any difficulty within 20 seconds and with the prescribed hand-grip of normal quality

Table 2. Demographic table

	Experimental (n = 10)	Control (n = 10)
Age, median (IQR)	75.5 (79-73.25)	47 (52-30.25)
Male , N	4	7

Table 3. Mean performance across groups

	Groups			Significance testing:	
	Experimental group without exoskeleton	Experimental group with exoskeleton	Control	No Exoskeleton vs. Exoskeleton	Exoskeleton vs Control
Range of Motion, Mean (SD)					
Finger 1					
Joint 1 (Extension)	10.6 (3.4)	35.6 (3.2)	35.9 (2.9)	p <0.001	p = 0.85
Joint 1 (Flexion)	5.7 (2.4)	62.3 (2.7)	61.9 (2.1)	p <0.001	p = 0.71
Joint 2 (Flexion)	19.4 (2.4)	85.2 (1.8)	87.4 (1.3)	p <0.001	p = 0.01
Joint 3 (Flexion)	13.0 (4.1)	37.7 (1.8)	40.1 (3.2)	p <0.001	p = 0.05
Finger 2					
Joint 1 (Extension)	8.8 (3.6)	33.9 (2.5)	36.0 (2.7)	p < 0.001	p = 0.10
Joint 1 (Flexion)	7.9 (2.8)	59.7 (2.9)	62.8 (1.7)	p < 0.001	p = 0.01

Joint 2 (Flexion)	19.7 (2.8)	84.1 (1.9)	86.6 (2.0)	p < 0.001	p = 0.01
-------------------	------------	------------	------------	-----------	----------

Joint 3 (Flexion)	12.1 (4.3)	38.6 (2.8)	41.3 (2.8)	p < 0.001	p = 0.05
-------------------	------------	------------	------------	-----------	----------

Finger 3

Joint 1 (Extension)	10.0 (3.1)	34.3 (2.3)	36.7 (2.2)	p < 0.001	p = 0.03
---------------------	------------	------------	------------	-----------	----------

Joint 1 (Flexion)	7.8 (2.6)	61.7 (3.2)	63.6 (2.3)	p < 0.001	p = 0.16
-------------------	-----------	------------	------------	-----------	----------

Joint 2 (Flexion)	8.6 (4.0)	84.5 (1.6)	86.9 (2.4)	p < 0.001	p = 0.02
-------------------	-----------	------------	------------	-----------	----------

Joint 3 (Extension)	8.7 (3.5)	39.0 (2.8)	42.0 (2.9)	p < 0.001	p = 0.04
---------------------	-----------	------------	------------	-----------	----------

Finger 4

Joint 1 (Extension)	9.7 (2.8)	36.0 (2.9)	36.3 (2.5)	p < 0.001	p = 0.84
---------------------	-----------	------------	------------	-----------	----------

Joint 1 (Flexion)	8.5 (3.1)	59.1 (2.8)	63.0 (2.3)	p < 0.001	p < 0.001
-------------------	-----------	------------	------------	-----------	-----------

Joint 2 (Flexion)	12.5 (4.9)	84.3 (2.1)	86.3 (2.4)	p < 0.001	p = 0.07
-------------------	------------	------------	------------	-----------	----------

Joint (Extension)	12.5 (4.9)	39.4 (3.0)	41.4 (2.6)	p < 0.001	p = 0.13
-------------------	------------	------------	------------	-----------	----------

Grip Force, Mean (SD)	4.3 lbs (2.02) ^b	38.1 lbs (3.67)	58 lbs (5.03)	p < 0.001	p < 0.001
-----------------------	-----------------------------	-----------------	---------------	-----------	-----------

Solleramn Hand Function Test, Mean (SD)	17.1 (9.73)	74.9 (4.91)	78.4 (2.01)	p < 0.001	p = 0.06
---	-------------	-------------	-------------	-----------	----------

^aJoint 1: Metacarpophalangeal Joint, Joint 2: Proximal Interphalangeal Joint, Joint 3: Distal Interphalangeal Joint

^bTwo participants were not able to grip the device, receiving a score of 0



Figure 1. Overview of the HANDLINK exoskeleton

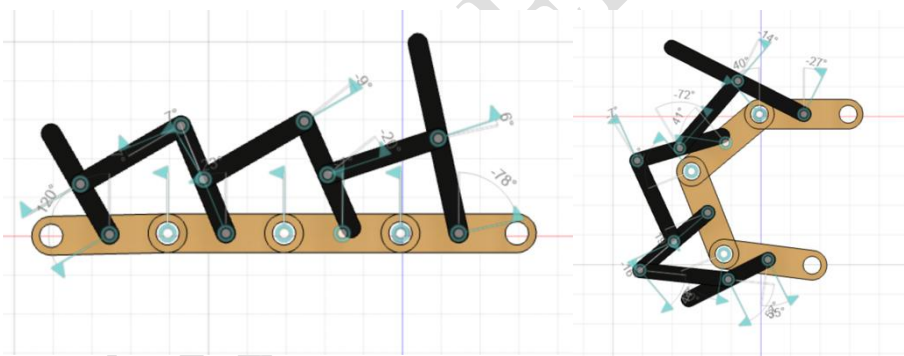

Figure 2. HANDLINK CAD concept. The mechanism for only a single finger is shown.

REFERENCES

1. *Neurosciences - stroke facts*. UTMBHealthCOM. (n.d.). Retrieved October 11, 2022, from <https://www.utmbhealth.com/services/neurology/procedures-conditions/stroke/stroke-facts>
2. Gresham, G. E., Duncan, P. W., Stason, W. B., Adams, H. P., Adelman, A. M., Alexander, D. N., Bishop, D. S., Diller, L., Donaldson, N. E., Granger, C. V., Holland, A. L., Kelly-Hayes, M., McDowell, F. H., Myers, L., Phipps, M. A., Roth, E. J., Siebens, H. C., Tarvin, G. A., & Trombly, C. A. (1995). Post-stroke rehabilitation: Assessment, referral and patient management. *American Family Physician*, 52(2), 461-470.
3. Dobkin B. H. (2005). Clinical practice. Rehabilitation after stroke. *The New England journal of medicine*, 352(16), 1677–1684. <https://doi.org/10.1056/NEJMcp043511>
4. Carmeli, E., & Liebermann, D. G. (2007). The function of the aging hand. In *Geriatric Rehabilitation Manual* (pp. 435–438). Elsevier. <https://doi.org/10.1016/b978-0-443-10233-2.50072-9>
5. Shahid, T., Gouwanda, D., Nurzaman, S. G., & Gopalai, A. A. (2018). Moving toward soft robotics: A decade review of the design of hand exoskeletons. *Biomimetics*, 3(3), 17.
6. du Plessis, T., Djouani, K., & Oosthuizen, C. (2021). A review of active hand exoskeletons for rehabilitation and assistance. *Robotics*, 10(1), 40.
7. Lusardi, R., Tomelleri, S., & Wherton, J. (2021). Living with assistive robotics: exploring the everyday use of exoskeleton for persons with spinal cord injury. *Frontiers in Medical Technology*, 56.
8. Fitzgerald, K. (2017). Design of Customizable Assistive Utensil Grip (Doctoral dissertation, Worcester Polytechnic Institute).

9. Jones, G., & Stopforth, R. (2016). Mechanical design and development of the touch hand ii prosthetic hand. *RD J. South African Inst. Mech. Eng*, 32, 23-34.

10.

. Fontana, M., Dettori, A., Salsedo, F., & Bergamasco, M. (2009, May). Mechanical design of a novel hand exoskeleton for accurate force displaying. In *2009 IEEE International Conference on Robotics and Automation* (pp. 1704-1709). IEEE.23. Lotze, M., & Halsband, U. (2006). Motor imagery. *Journal of Physiology-paris*, 99(4-6), 386-395.

11. *Limited mobility gripping aids*. The Active Hands Company. (2022, November 18).

Retrieved November 20, 2022, from <https://www.activehands.com/>

12. Chiri, A., Giovacchini, F., Vitiello, N., Cattin, E., Roccella, S., Vecchi, F., & Carrozza, M. C. (2009, October). HANDEXOS: Towards an exoskeleton device for the rehabilitation of the hand. In *2009 IEEE/RSJ international conference on intelligent robots and systems* (pp. 1106-1111). IEEE.

13. Yun, Y., Dancausse, S., Esmatloo, P., Serrato, A., Merring, C. A., Agarwal, P., & Deshpande, A. D. (2017, May). Maestro: An EMG-driven assistive hand exoskeleton for spinal cord injury patients. In *2017 IEEE international conference on robotics and automation (ICRA)* (pp. 2904-2910). IEEE.

14. Yap, H. K., Lim, J. H., Nasrallah, F., Goh, J. C., & Yeow, R. C. (2015, May). A soft exoskeleton for hand assistive and rehabilitation application using pneumatic actuators with variable stiffness. In *2015 IEEE international conference on robotics and automation (ICRA)* (pp. 4967-4972). IEEE.

15. Meng, Q., Xiang, S., & Yu, H. (2017). Soft robotic hand exoskeleton systems: Review and challenges surrounding the technology. *Proceedings of the 2017 2nd International*

Conference on Electrical, Automation and Mechanical Engineering (EAME 2017).

<https://doi.org/10.2991/eame-17.2017.45> ?

16. El-Atab, N., Mishra, R. B., Al-Modaf, F., Joharji, L., Alsharif, A. A., Alamoudi, H., ... & Hussain, M. M. (2020). Soft actuators for soft robotic applications: a review. *Advanced Intelligent Systems*, 2(10), 2000128.

17. Polygerinos, P., Galloway, K. C., Savage, E., Herman, M., O'Donnell, K., & Walsh, C. J. (2015, May). Soft robotic glove for hand rehabilitation and task specific training. In 2015 IEEE international conference on robotics and automation (ICRA) (pp. 2913-2919). IEEE.

18. Cao, H., & Zhang, D. (2016, December). Soft robotic glove with integrated sEMG sensing for disabled people with hand paralysis. In *2016 IEEE International Conference on Robotics and Biomimetics (ROBIO)* (pp. 714-718). IEEE. 19. Mulas, Marcello & Folgheraiter, Michele & Gini, Giuseppina. (2005). An EMG-

controlled Exoskeleton for Hand Rehabilitation. *Rehabilitation Robotics, ICORR 2005*

9th International Conference on. 371 - 374. 10.1109/ICORR.2005.1501122.

20. Parry, R., Macias Soria, S., Pradat-Diehl, P., Marchand-Pauvert, V., Jarrassé, N., & Roby-Brami, A. (2019). Effects of hand configuration on the grasping, holding, and placement of an instrumented object in patients with hemiparesis. *Frontiers in neurology*, 10, 240. 21. Lucas, L.,

DiCicco, M., & Matsuoka, Y. (2004). An EMG-controlled hand exoskeleton for natural pinching. *Journal of Robotics and Mechatronics*, 16, 482-488.

122 Edelman, B. J., Baxter, B., & He, B. (2015). EEG source imaging enhances the decoding of complex right-hand motor imagery tasks. *IEEE Transactions on Biomedical Engineering*, 63(1), 4-14.

23. Lotze, M., & Halsband, U. (2006). Motor imagery. *Journal of Physiology-paris*, 99(4-6), 386-395.

24. Jeannerod, M. (1995). Mental imagery in the motor context. *Neuropsychologia*, 33(11), 1419-1432.
25. Frolov, A. A., Mokienko, O., Lyukmanov, R., Biryukova, E., Kotov, S., Turbina, L., ... & Bushkova, Y. (2017). Post-stroke rehabilitation training with a motor-imagery-based brain-computer interface (BCI)-controlled hand exoskeleton: a randomized controlled multicenter trial. *Frontiers in neuroscience*, 11, 400.
26. Fontana, M., Dettori, A., Salsedo, F., & Bergamasco, M. (2009, May). Mechanical design of a novel hand exoskeleton for accurate force displaying. In *2009 IEEE International Conference on Robotics and Automation* (pp. 1704-1709). IEEE.
23. Lotze, M., & Halsband, U. (2006). Motor imagery. *Journal of Physiology-paris*, 99(4-6), 386-395.
27. Sollerman, C., & Ejeskär, A. (1995). Sollerman hand function test: a standardised method and its use in tetraplegic patients. *Scandinavian Journal of Plastic and Reconstructive Surgery and Hand Surgery*, 29(2), 167-176.
28. Sollerman Hand Function Test. (2021, January 31). *Physiopedia*, . Retrieved 19:39, November 17, 2022 from https://www.physio-pedia.com/index.php?title=Sollerman_Hand_Function_Test&oldid=266115.
29. Gates, D. H., Walters, L. S., Cowley, J., Wilken, J. M., & Resnik, L. (2016). Range of Motion Requirements for Upper-Limb Activities of Daily Living. *The American journal of occupational therapy : official publication of the American Occupational Therapy Association*, 70(1), 7001350010p1–7001350010p10. <https://doi.org/10.5014/ajot.2016.015487>
30. Lupton-Smith, A., Fourie, K., Mazinyo, A., Mokone, M., Nxaba, S., & Morrow, B. (2022). Measurement of hand grip strength: A cross-sectional study of two dynamometry devices. *South African Journal of Physiotherapy*, 78(1), 5

UNDER PEER REVIEW