

**Cost Effective Maintenance and Machine Reliability for Food Manufacturing**

**Industries using Optimal Maintenance Strategy**

**Abstract**

An optimal maintenance strategy for – cost effective maintenance and machine reliability in food manufacturing industries was developed in this study. Maintenance and cost parameters were - employed to develop cost-reliability based model in terms of an optimal maintenance using lingo solver. The developed cost-reliability based model considered system's reliability, cost of equipment failure, preventive maintenance, corrective maintenance and downtime cost associated with - equipment maintenance. A case of a food manufacturing company in Nigeria was observed and the data was used to evaluate the model. It is imperative to know that, the developed optimal maintenance strategy provided better cost savings and improved system reliability than the current maintenance cost and machine reliability of the industrial case study

**Keywords: Lingo Solver; Cost Effective; Cost-Reliability Parameters; Maintenance Strategy; Optimization; Maintenance Cost; Food Manufacturing.**

**1.0 INTRODUCTION**

The main focus for food manufacturers is to improve efficiency and profitability through the reduction of total manufacturing costs by optimizing operation processes and maintenance activities achieved through continuously improved machine reliability and an efficient maintenance strategy. Some studies (Al-Najjar & Alsyouf, 2003, 2004; Al-Najjar, 2007; Alsyouf, 2009), have discussed the economic implications of maintenance as it applies to

food manufacturing industries showing how and effective maintenance policy affects productivity and profitability of a manufacturing process.

According to Turuna Seecharan, Ashraf Labib (2016) the effective maintenance of food manufacturing component is a vital strategic task given the increasing demand on sustained availability of those components used for manufacturing. This is crucial as sudden failures of these components can be prohibitively expensive because they result in immediate lost production outcome, inefficient quality characteristics and poor customer satisfaction.

Overall the importance of maintenance is ever increasing as a result of the widespread automation of manufacturing systems and the capital expenditure allocated to it, thus making maintenance of manufacturing components an investment opportunity to be maximised and not a cost centre (Horenbeek et al., 2011) While the economic downturn continuously drives manufacturing organisations to seek for more efficient strategies to manage maintenance, globalization has increased the pressure on organizations and companies to operate in the most efficient and economical way. This predisposition promotes that companies concentrate immensely on their core businesses, outsource less profitable departments and services to reduce costs (Achermann, 2008). However, only a few have the internal resources to implement such practical culture -(Eti et al., 2006). Hence the aim of this study is to develop an optimal maintenance strategy for - cost effectiveness of maintenance and machine reliability in food manufacturing industries.

## **2.0 Problem Statement**

The organization under study runs a computerized manufacturing process for the manufacturing and processing of noodles for human consumption. This organisation - adopts corrective maintenance as its preferred maintenance strategy only, which can be described as a reactive, firefighting strategy. The information obtained from the maintenance team of the

organisation was that most faults and failures can be fixed manually by the maintenance team in a relatively short period of time. But, there have been incidents and occasions where breakdowns resulted in long unavailability of the manufacturing physical assets. Also observed was the effect of faults and failures on the manufacturing process as depicted in figure 1.

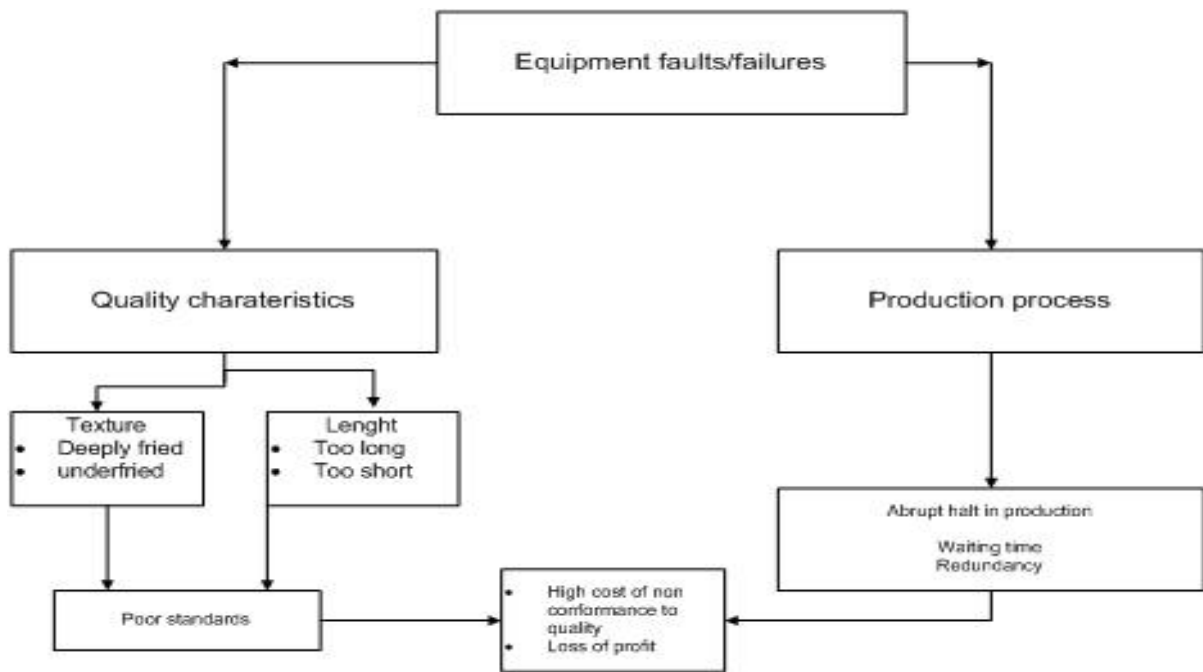

Fig 1: Faults/Failures and implications

The implications observed are in contradiction of the maintenance goals and objectives of the organisation which is that in the long run maintenance should ensure equipment availability in order to produce products at the compulsory quantity and quality levels.

### 3.0 Research Methodology

The relevants data were collected through direct observations of the manufacturing and maintenance processes, for 26,234 hours of equipment faults and failures and equipment cost data for thirty six months. The data were obtained from a food and beverage at Chicason Drive, Umudim, Nnewi, Anambra State, Nigeria.

The optimal method used a cost based approach to minimize total maintenance cost while assuring the desired improvement of machine reliability. The system was a repairable multi-component system arranged in series with each of the components subject to degradation and follow non-homogeneous Poisson process (NHPP) with an increasing rate of occurrence of failure ( $t$ ). The following notations of the model are defined:

- $N$ : Number of manufacturing components
- $T$ : Length of planning scope
- $J$ : Number of intervals
- $\lambda$ : scale parameter (failure function) of component  $i$
- $\beta$ : shape parameter (improvement/degradation) of component  $i$
- $\alpha_{pmi}$ : Age reduction factor of preventive maintenance on component  $i$
- $FC_i$ : cost of performing maintenance due to failure of component  $i$
- $PMC_i$ : Cost for preventive maintenance for component  $i$
- $CRC_i$ : Cost of corrective replacement for component  $i$
- $DC$ : cost of downtime of the manufacturing system
- $RR$ : Required reliability of the system of components
- $X_{i,j}$ : The effective age of component  $i$  at the start of period  $j$
- $XX_{i,j}$ : The effective age of component  $i$  at the end of period  $j$

Assumptions:

- If preventive maintenance is performed on any component, the effective age of the component is reduced by 30% thus the age reduction factor of preventive maintenance on a component  $i$  ( $\alpha_{pmi}$ ) is assigned a fixed value of 0.7.
- The failure of the manufacturing components is characterized by Weibull distribution
- There is minimum acceptable required reliability of the components

- The skilled and unskilled used for the maintenance are the employees of the company so they are always available.

### 3.1 Case Study of a Company

The study was carried out in a food and beverage manufacturing company “Tummy Tummy Foods Industries limited” located at Chicason Drive, Umudim, Nnewi, Anambra State, Nigeria. The company majors in the production of edible foods (Tummy Tummy Instant Noodles) for human consumption. The production line is connected in series as illustrated in figure 2

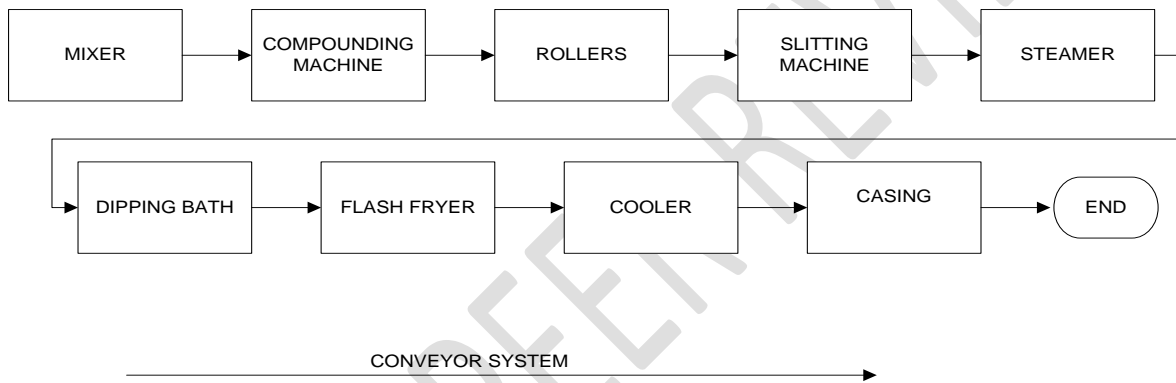

**Figure 2: Illustration of the Production line**

### 3.2 Reliability Parameters

To estimate the shape ( $\lambda$ ) and scale ( $\beta$ ) parameters in the model, maximum likelihood estimation as illustrated by (Trindade & Nathan, 2005) is applied in this study

$$\lambda = \frac{\sum_{q=1}^k N_q}{\sum_{q=1}^k T_q^{\beta} - S_q^{\beta}} \quad (1)$$

$$\beta = \frac{\sum_{q=1}^k N_q}{\lambda \sum_{q=0}^k (T_q^{\beta} \ln T_q - S_q^{\beta} \ln S_q) - \sum_{q=1}^k \sum_{i=1}^{N_q} \ln X_{iq}} \quad (2)$$

Where

$K$  = no of systems,

$S$  and  $T$  = start and end times of observation,

$N_q$  = number of failures on the  $q$ th system

$X_{iq}$  is the age of the  $q$ th system at the  $i$ th failure.

**B**

$\lambda$

The parameter  $\lambda$  is used to understand the reliability growth of the system under the following conditions:

- If  $0 < \lambda < 1$ , the failure/repair rate is decreasing. Thus, system is improving over time.
- If  $\lambda = 1$ , the failure/repair rate is constant. Thus, system is remaining stable over time.
- If  $\lambda > 1$ , the failure/repair rate is increasing. Thus, system is deteriorating over time.

### 3.3 System Cost Function

Taking into account that any maintenance or replacement action that is carried out is associated with cost, the cost of maintenance or replacement of component  $i$  at the end of period  $j$  include the total sum of failure cost, cost of preventive maintenance, cost of replacement of component and downtime cost.

To calculate for failure cost, the expected number of failures for component  $i$  in period  $j$  the expected number of failures for component  $i$  in period  $j$  is calculated and multiplied by the cost of failure for component  $i$

$$FC_i = F_i \times [N_{i,j}] \quad \text{for } i = 1, \dots, N; j = 1, \dots, T \quad (3)$$

Where

$F_i$  = cost of failure for component  $i$

$[N_{i,j}]$  = expected number of failures for component  $i$  in period  $j$

From equation 3,

$$[N_{i,j}] = \hat{\lambda}_i [(XX_{i,j})^{\beta_i} - (X_{i,j})^{\beta_i}] \quad \text{for } i = 1, \dots, N; j = 1, \dots, T$$

Therefore

$$FC_i = F_i \times \hat{\lambda}_i [(XX_{i,j})^{\beta_i} - (X_{i,j})^{\beta_i}] \quad \text{for } i = 1, \dots, N; j = 1, \dots, T \quad (4)$$

Cost of preventive maintenance  $PMC_i$  refers to the cost incurred while component  $i$  is maintained. It includes cost of consumables ( $CCC_i$ ), cost of condition-based maintenance ( $CCBM_i$ ), and cost of time based maintenance ( $CTBM_i$ ). Where cost of consumables includes the cost of consumable material and equipment used while carrying out preventive maintenance activities such as cost of lubricating oil ( $CLO_{ij}$ ), cost of component wires ( $CCW_{ij}$ ), cost of replacement vital parts (screw nuts, belts etc) ( $CRVP_{ij}$ ), cost lubricating grease ( $CLG_i$ ). The cost of condition-based maintenance includes cost of inspections ( $CI_{ij}$ ), cost of diagnostic actions ( $CDA_{ij}$ ), travel cost ( $CT_{ij}$ ), labour cost ( $CL_{ij}$ ) and cost of delayed production ( $CDP_{ij}$ ). While cost of time-based maintenance includes the cost of preventive oil change ( $CPOC_{ij}$ ), cost of equipment material change ( $CEMC_{ij}$ ).

Thus  $PMC_i = CLO_{ij} + CCW_{ij} + CRVP_{ij} + CLG_{ij} + CI_{ij} + CDA_{ij} + CT_{ij} + CL_{ij} + CDP_{ij} +$

$$CPOC_{ij} + CEMC_{ij} \quad \text{for } i = 1 \dots N; j = 1, \dots, T$$

Where  $CCC_{ij} = CLO_{ij} + CCW_{ij} + CRVP_{ij} + CLG_{ij}$

$$CCBM_{ij} = CI_{ij} + CDA_{ij} + CT_{ij} + CL_{ij} + CDP_{ij}$$

$$CTBM_{ij} = CPOC_{ij} + CEMC_{ij}$$

$$\text{Thus } PMC_i = CCC_{ij} + CCBM_{ij} + CTBM_{ij} \quad \text{for } i = 1 \dots N; j = 1, \dots, T \quad (5)$$

Cost of corrective maintenance of component  $i$  is the cost  $CRC_i$  incurred when component  $i$  is replaced at the end of period  $j$  with a new component  $i$ . It includes cost of diagnostic actions, Cost of repair actions, Cost and equipment hire and travel expenses, labour cost and administrative cost.

Thus

$$CMC_i = CDA_{ij} + CRA_{ij} + CEH_{ij} + TEC_{ij} + LC_{ij} + AC_{ij} \quad \text{for } i = 1 \dots N; j = 1, \dots, T \quad (6)$$

The cost of downtime of the manufacturing system  $DC$  is the cost lost when component  $i$  is maintained or replaced at period  $j$

$$DC = DT \times PL \quad (8)$$

Where

$DT$ : Average duration for downtime

$PL$ : estimated profit loss per hour by the company due to downtime.

Thus the total cost of maintenance is the sum of all the cost defined for component  $i$  at period  $j$  and is expressed as follows:

Total Maintenance cost =

$$\sum_{i=1}^N \sum_{j=1}^T \{ F_i \times \lambda_i [(xx_{i,j})^{\beta_i} - (x_{i,j})^{\beta_i}] + CLO_{ij} + CCW_{ij} + CRVP_{ij} + CLG_{ij} + CI_{ij} + CDA_{ij} + CT_{ij} + CL_{ij} + CDP_{ij} + CPOC_{ij} + CEMC_{ij} + CDA_{ij} + CRA_{ij} + CEH_{ij} + TEC_{ij} + LC_{ij} + AC_{ij} \} + \sum_{j=1}^T [DC]$$

(9)

### 3.4 System Reliability Function

The reliability of the system at the interval  $X_{i,j}$ , and  $XX_{i,j}$  is given as:

$$R_j = e^{-\lambda t^\beta}$$

Where  $t = ((XX_{i,j}) - (X_{i,j}))$

Thus

$$R_j = e^{-[\lambda_i [(XX_{i,j})^{\beta_i} - (X_{i,j})^{\beta_i}]]} \quad (10)$$

The reliability of the system is measured at an instant. Case in point, the reliability of the system would be the reliability at the end of every period.

### 3.5 Formulation of Optimization Model for an Optimal Maintenance Strategy Based on Cost and Reliability

The parameters, cost functions and reliability equation have been defined, the optimal method is presented as a multi-objective optimization problem to minimize cost and maximize reliability:

**Minimize Total cost**

$$= \sum_{i=1}^N \sum_{j=1}^T \{ F_t \times \lambda_i [(XX_{i,j})^{\beta_i} - (X_{i,j})^{\beta_i}] + CLO_{ij} + CCW_{ij} + CRVP_{ij} + CLG_{ij} + Cl_{ij} + CDA_{ij} + CT_{ij} \\ + CL_{ij} + CDP_{ij} + CPOC_{ij} + CEMC_{ij} + CDA_{ij} + CRA_{ij} + CEH_{ij} + TEC_{ij} + LC_{ij} + AC_{ij} \} + \sum_{j=1}^T [DC]$$

**Maximize Reliability**

$$= e^{-[\lambda_i [(XX_{i,j})^{\beta_i} - (X_{i,j})^{\beta_i}]]}$$

Subject to

$$X_{i,j} = 0 \quad \text{For } i = 1, \dots, N; j = 1, \dots, T$$

$$XX_{i,j} = X_{i,j} + \frac{T}{j} \quad \text{For } i = 1, \dots, N; j = 1, \dots, T$$

$$X_{i,j+1} = 0 \quad \text{For } i = 1, \dots, N; j = 1, \dots, T$$

$$PMC_{ij}, CRC_{ij} = 0 \text{ or } 1 \quad \text{For } i = 1, \dots, N; j = 1, \dots, T$$

(11)

The first constraint indicated that the initial age of each component is zero,

The second constraint accounts for the changes in age thus representing the effective age of component  $i$  at the end of period  $j$ .

The third constraint specifies that if a component is replaced with another new component then  $X_{i,j} = 0$ ,  $CRC_{ij} = 1$ ,  $PMC_{ij} = 0$ . If a component is maintained then  $CRC_{ij} = 0$ ,  $PMC_{ij} = 1$ .

#### 4.0 Results and Discussion

An analysis of the total cost of maintenance by the company was carried out using optimal maintenance strategy. The main goal of this analysis is to create a model that forecasts the future cost of maintenance at a given time parameter with the current maintenance strategy of the company, hence a trend analysis on the historical data, and a corresponding model obtained. The result showed an increasing trend line of total maintenance cost as seen in figure 3.

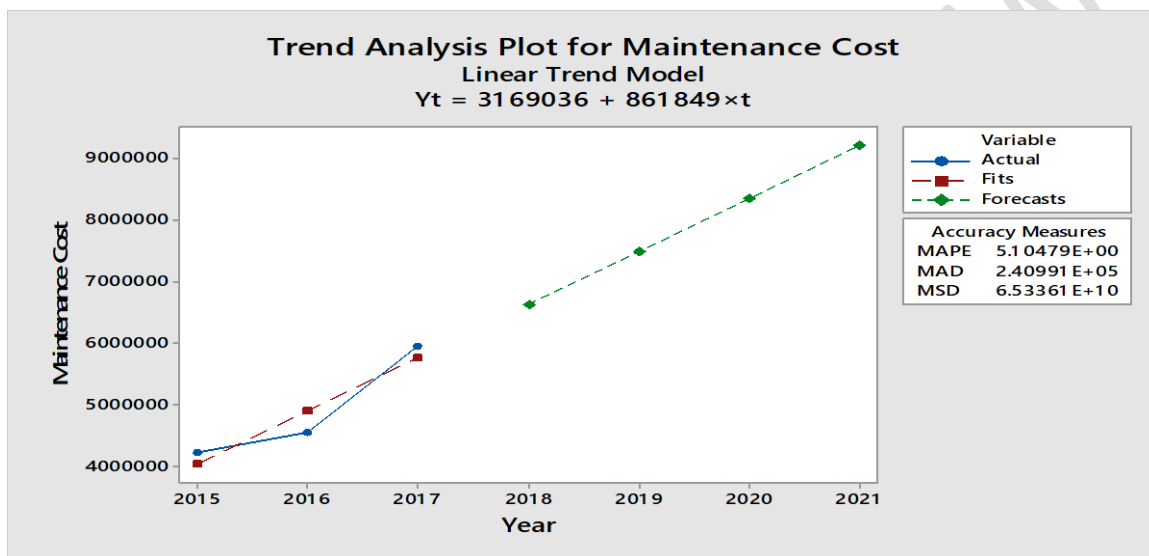

Fig 3: Trend Plot of Total Maintenance Cost with Future Forecast

From the analysis it was found that in the year 2021, if the current maintenance strategy is still maintained, the total cost is expected to be about ₦ 9,201,979. Table 1 shows the yearly forecast from 2018 to 2021.

**Table 1: Future Maintenance Cost Forecast**

Period	Forecast
2018	₦ 6,616,432
2019	₦ 7,478,281
2020	₦ 8,340,130
2021	₦ 9,201,979

Data from the manufacturing firm was applied to the optimization model developed in equation 11 and was programmed into lingo 17.0 software for an optimal solution. The cost results obtained were benchmarked with the future maintenance cost forecast.

**Table 2: Parameters of manufacturing firm used**

Time Period		36 months					
DC		₦197,561					
N	Component	Shape ( $\beta$ )	Scale ( $\lambda$ )	$\alpha_{pmi}$	Failure Cost	Preventive Maintenance Cost	Corrective Maintenance Cost
1	Conveyor System	1.5855	3396.50	0.7	₦ 884,210	₦387,450	₦ 496,760
2	Mixer system	1.7610	3375.42	0.7	₦ 366,415	₦93,855	₦ 272,560
3	Roller system	1.7397	3254.14	0.7	₦ 430,680	₦ 92,680	₦ 338,000
4	Slitter	1.7123	3252..65	0.7	₦ 513,322	₦ 99,500	₦ 413,822
5	Compounding machine	1.6852	3170.13	0.7	₦ 618,685	₦ 231,685	₦ 387,000

Figure 4 and table 3 show- the optimal pareto fronts from lingo 17 with associated cost. Each front presents an optimal maintenance schedule and at 50% the objective function is achieved at ₦7,593,578 with system reliability in between the range of 94% and 99.7% over the defined planning period of 36 month.

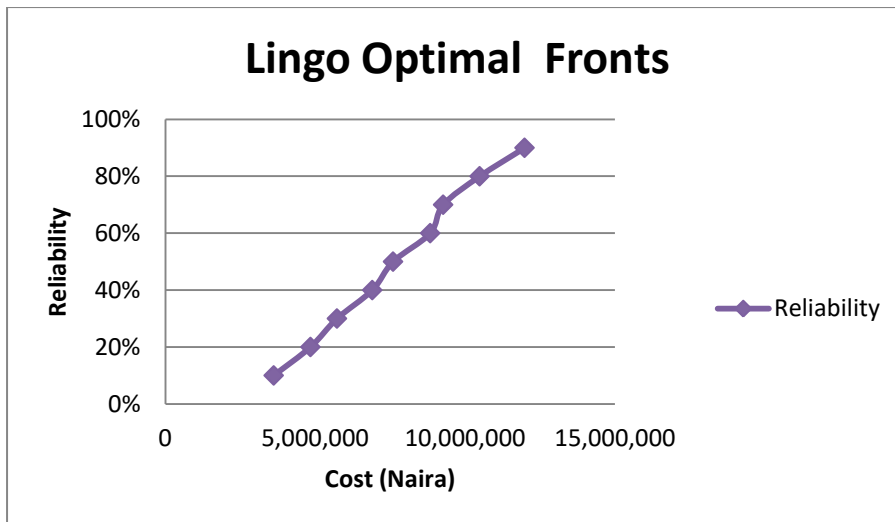

**Fig 4: Lingo Optimal Fronts for Reliability**

**Table 3: Lingo Optimal and Associated Costs**

Reliability	Cost
10%	3,612,769
20%	4,839,280
30%	5,722,900
40%	6,900,431
50%	7,593,578
60%	8,832,608
70%	9,264,333
80%	10,480,991
90%	11,980,000

The optimal maintenance strategy obtained at the objective function is presented in table 4:

**Table 4: Optimal Maintenance strategy (Cost = ₦7, 593,578, Reliability = 99.7%)**

MONTHLY SCHEDULE																																						
N	1	2	3	4	5	6	7	8	9	10	11	12	13	14	15	16	17	18	19	20	21	22	23	24	25	26	27	28	29	30	31	32	33	34	35	36		
1	-	-	P	-	-	-	P	C	-	-	-	-	P	C	-	-	-	-	-	P	-	-	C	-	-	P	-	-	-	-	-	-	P	-	-	-	P	
2	-	-	P	-	-	-	-	-	-	-	-	-	P	C	-	-	P	-	-	-	-	-	C	-	-	-	-	-	C	-	-	-	-	-	-	-	-	P
3	-	-	P	-	-	-	P	C	-	-	-	-	P	-	-	-	P	-	-	P	-	-	C	-	-	-	-	-	-	-	-	-	-	P	-	-	-	P
4	-	-	P	-	-	-	P	C	-	-	-	-	P	-	-	-	-	-	-	-	-	-	C	-	-	-	-	-	C	-	-	P	-	-	-	-	-	P
5	-	-	P	-	-	-	-	-	-	-	-	-	P	C	-	-	-	-	-	P	-	-	C	-	-	P	-	-	P	-	-	-	-	-	-	-	-	P

KEY: N = Number of Components; 1 = Conveyor System; 2 = Mixer System; 3 = Roller System; 4 = Slitter System; 5= Compounding Machine;

P: Preventive Maintenance; C: Corrective Maintenance

The system reliability as presented in figure 5 shows that the reliability of the system lies between 94% and 99.7% over the defined planning period of 36 months with average reliability over the planning period being 97.2%.

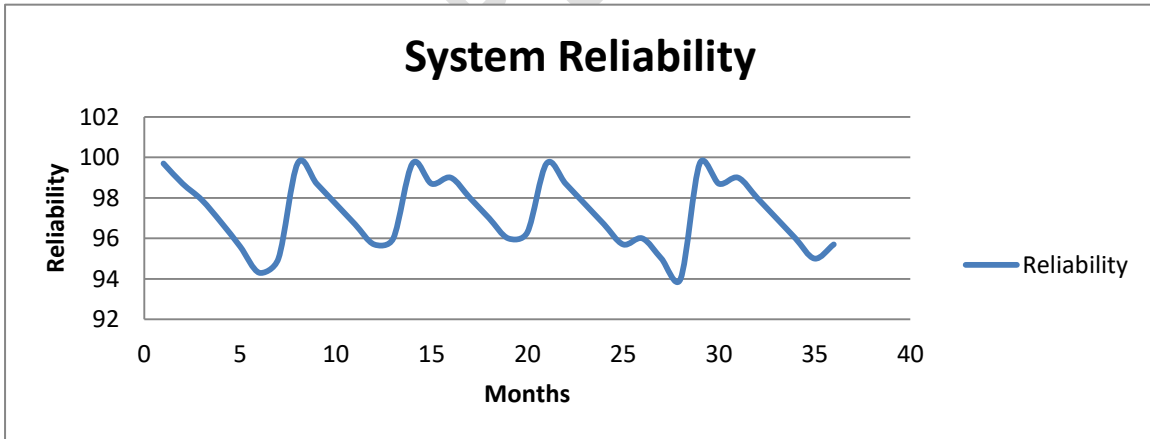

**Fig 5: System Reliability** (Cost = ₦7, 593,578, Reliability = 99.7%)

The purpose of the optimal maintenance strategy is to ascertain the optimal combination of maintenance actions that meets the objectives of the manufacturing firm. These can either be to maximize reliability or minimize cost. At 50% pareto front, the optimal fronts provided a

better cost objective and improved reliability (Cost = ₦7, 593,578, Reliability = 99.7%) than that the current maintenance scenario at the food manufacturing company at cost ₦9,201,979.

**Table 5: Cost Saving and Reliability Improvement**

Categories	Reliability	Cost	Cost Savings
Case Study	93.82%	₦ 9,201,979	=====
<b>Solution Method</b>			
Lingo Optimal Solution	99.7%	₦7,593,578	61.7%

## 5.0 Conclusion

The developed optimal maintenance method provides a better cost savings and improved reliability thus Maintenance of manufacturing components can be improved using reliability parameters and cost of those components. For the method to be effective, input data needs to be as exact as possible. Therefore, there is a need for manufacturing companies to ensure that failure history and cost of maintenance/ replacement of every component are properly documented to ensure accurate reliability prediction and cost forecasting.

## References

Achermann, D. (2008). *Modelling , Simulation and Optimization of Maintenance Strategies under Consideration of Logistic Processes.*

- Al-Najjar, B. (2007). The lack of maintenance and not maintenance which costs: A model to describe and quantify the impact of vibration-based maintenance on company's business. *International Journal of Production Economics*, 107(1), 260–273.
- Al-Najjar, B., & Alsayouf, I. (2003). Selecting the most efficient maintenance approach using fuzzy multiple criteria decision making. *International Journal of Production Economics*, 84(1), 85–100.
- Al-Najjar, B., & Alsayouf, I. (2004). Enhancing a company's profitability and competitiveness using integrated vibration-based maintenance. *European Journal of Operational Research*, 157(3), 643–657.
- Al-najjar, B., & Gomiscek, B. (2015). The role of maintenance in improving company's competitiveness and profitability: A case study in a textile company. *Journal of Manufacturing Technology Management*, 25(4), 22–40. <http://doi.org/10.1108/JMTM-04-2013-0033>
- Alsayouf, I. (2009). Maintenance practices in Swedish industries: Survey results. *International Journal of Production Economics*, 121(1), 212–223. <http://doi.org/10.1016/j.ijpe.2009.05.005>
- Eti, M. ., Ogaji, S. O. T., & Probert, S. D. (2006). Development and implementation of preventive-maintenance practices in Nigerian industries. *Applied Energy*, 83, 1163–1179. <http://doi.org/10.1016/j.apenergy.2006.01.001>
- Horenbeek, A. Van, Pintelon, L., & Muchiri, P. (2011). Maintenance optimization models and criteria, 1(3), 189–200. <http://doi.org/10.1007/s13198-011-0045-x>
- Trindade, D. C., & Nathan, S. (2005). Simple Plots for Monitoring the Field Reliability of Repairable Systems. In *Annual Reliability and Maintainability Symposium (RAMS)*. Alexandria, Virginia.
- Turuna Seecharan, Ashraf Labib, A. J. (2016). Journal of Quality in Maintenance Engineering Maintenance Strategies: Decision Making Grid vs . Jack-Knife Diagram Abstract. *Journal of Quality in Maintenance Engineering*, 23(6), 1–31.