

# Experimental Study of Hybrid Flat-Plate Solar Collector/Nocturnal Radiator For Water Heating and Cooling in Owerri, Nigeria

## ABSTRACT

The quest for new, alternative energy sources and technologies have risen due to myriads of crises associated with fossil fuel dominated energy mix in Nigeria, in terms of supply and its adverse effect on the environment.

Experimental study of hybrid flat-plate solar collector/nocturnal radiator for water heating and cooling in Owerri, Nigeria, is presented. The experimental rig consists of a single flat surface (absorber plate) made of a mild steel plate, film-coated with an acrylic resin which made the surface spectrally selective. Underneath, were arrays of copper tube risers. A sample test on acrylic resin's coating, on a metallic substrate showed that it has high clear spectral absorptivity (low emissivity) in the solar radiation band (0.2-0.3 $\mu\text{m}$ ) as well as low absorptivity (high emissivity) in the atmospheric window band (3-8 $\mu\text{m}$ ). A water reservoir 2m above was connected to the system inlet header to supply water. Experimental data were harvested for days/nights through a read-out basic language programmed data logger. The experimentation were conducted under the metrological condition of Federal Polytechnic Nekede Owerri (5.49°N, 7.02°E), South-East Nigeria. The results obtained under solar heating phase showed a peak water temperature of 60°C at a plate temperature of about 80°C and a heat collection efficiency of 31%. The peak insolation was about 900W/m<sup>2</sup> and the ambient temperature was between 27°C and 32°C throughout the diurnal phase. Also, under the nocturnal radiation phase, a cooling power of 41w/m<sup>2</sup> was achieved during cooling on clear night and about 20w/m<sup>2</sup> on a cloudy night. Water temperature in the range of 19°C to 20°C was recorded at temperature depression of about 5°C. The night sky temperature of the location was obtained in the range 10°C to 16°C for the period under study. The result shows that the system can provide substantial energy savings when incorporated into building structure, to providing hot and cold water for domestic/process use, space heating and cooling applications.

**Keywords:** Hybrid, flat-plate collector, radiator, cooling, heating, temperature, nocturnal

## 1. INTRODUCTION

The current world technological trend of increasing energy demand, insufficient grid electricity supply, increasing costs and shortage of fossil fuel resource which have been major drivers of energy supply worldwide and the attendant effects on the environment in form of pollutions, greenhouse gas emissions and general environmental imbalance are current global topical issues and requires researchers intervention. The concern that fossil fuel resources are tending towards exhaustion necessitated all efforts towards finding new, sustainable and alternative energy for energy savings in buildings. It is estimated that, at current rate of consumption of fossil fuels, the world will run-out of oil in 40 years, natural gas in 60 years and coal in 180 years [1]. Renewable energy is believed to have the solution to the above challenges, as it is clean and has no adverse environmental effects.

Taking advantage of the diurnal solar radiation incident on the surface of the earth and the night-sky radiation concept (i.e. the fact that the higher atmosphere is much colder than the surface of the earth, as outer space is close to absolute zero temperature, at night), a hybrid solar collector/nocturnal radiator can be designed to harness the available diurnal solar energy and the night-sky radiant energy for water heating and cooling [2,3].

Solar radiation is concentrated within  $0.2\text{-}3\mu\text{m}$  spectral region known as solar radiation band, and water flowing through the system can absorb enough heat from the incoming solar radiation during the day. However, in  $8\text{-}13\mu\text{m}$  wavelength band, known as the atmospheric window, the atmosphere has extremely high transmittance. Within this band, the system facing the sky at night can release enough energy to the cold ambient which can reduce the temperature of a fluid, e.g. water by running the fluid underneath the surface [4]. The hot and cold temperature fluid respectively, can be stored in reservoirs and used for space heating and cooling or other applications in the building. The efficiency of a solar collector depends on spectral absorptivity in solar radiation wavelength ( $0.2\text{-}3\mu\text{m}$ ) and heating loss of the collecting surface. To improve heat efficiency, high solar absorptivity and low heating loss must be ensured in designing a solar collector [5]. Also for nocturnal radiator, the radiative surface should have high spectral emissivity in the atmospheric window wavelength ( $8\text{-}13\mu\text{m}$ ) and very low in other band.

**Erell and Etzion [6]** converted solar collectors to cooling radiators. The result obtained gave a temperature depression of  $1.8^{\circ}\text{C}$  below the ambient conditions. The publication did reveal that coupling night time radiators with daytime solar collectors is within the realm of possibility and should be studied further.

**Balen et al [7]** designed a solar thermal system using flat-plate solar radiators for cooling and heating of water using **Polyethylene /polyphenylenoxid**. The results showed that system, with small modifications to the physical set-up, recorded a 32<sup>0</sup>C rise (heating) and depression of about 12<sup>0</sup>C at 25<sup>0</sup>C ambient condition in a clear sky (cooling) during summer in Irish weather.

**Alomar and Kiss [8]** studied solar heating and radiative cooling using uncovered flat plate collectors under Syrian climatic condition. It was proposed that simple uncovered roof collectors acting also as night sky radiators and heat exchangers with ambient air offer a simple and cheap solution to maintain human comfort in buildings among Syrian climatic conditions. Their work was more of theoretical analysis and equation formulations.

**Hosseinzadeh and Taherian [9]** reported an experimental and an analytical study of a radiative cooling system with unglazed flat-plate collectors in Babol, Iran. The results indicate that water temperature decreased 7 - 8<sup>0</sup>C and the average net cooling was from 23 to 52 W/m<sup>2</sup>, as the mass flow rate increases from 0.01 to 0.05 kg/s.

**Anderson et al [10]** theoretically and experimentally examined the performance of an unglazed solar collector for cooling. They reported a cooling capacity in the order of 50W/m<sup>2</sup> and are able to cool to well below the ambient temperatures experienced during the cooling season in such climates. Other works reviewed , are those that adopted spectrally selectivity surface to achieve both heating and cooling.

**Matsuta et al [11]**, designed and constructed a selective type solar collector-sky radiator (SCR) for heating and cooling, anticipating a result better than a Non-selective type solar collector (NSCR). The publication claimed a cooling radiation flux of 51 W/m<sup>2</sup> on a clear night, while still achieving 610 W/m<sup>2</sup> of solar collective flux in good conditions. This study gave promise to the concept of having a solar thermal collector during the day act as a sky radiator during the night, thus making use of all 24 hours in a day.

**Yiping et al [12]** in Tiajin, China, combined solar heating and nocturnal radiant cooling techniques to produce a heating and cooling system, with two sorts of acrylic resins as coating materials. The daily average heat-collecting efficiency are respectively about 32% and 20% with the maximum points of 50% and 30%, and night cooling capacity of about 20W/m<sup>2</sup> and 40W/m<sup>2</sup>.

**Mingke et al [5]** proposed a spectral selectivity surface for both solar heating and radiative cooling in their study using a Titanium, coated with polyethylene terephthalate (PET powder) called TPET, which recorded an average plate(Titanium) temperature of 90°C at maximum solar radiation in the range of 710W/m<sup>2</sup> and 925W/m<sup>2</sup> during heating with peak value at in Hefei, China.

**Nwaji et al [2]** numerically analyzed the dynamic performance of a hybrid solar collector/nocturnal radiator for water heating and cooling in Nigeria, using Titanium Polyethylenetherephthalate as substrate.

Results obtained showed that the maximum temperatures attained by the water during diurnal heating were in the range of 84.6 °C, 75.61 °C, 86.4 °C, 88.33 °C, and 93.67 °C while during the nocturnal cooling period, the minimum temperatures of water were in the range of 20.21 °C, 20.12 °C, 21.9 °C, 20.95 °C and 22.01 °C representing different cities.

The present work seeks to experimentally expand the study in the deployment single hybrid surface for diurnal solar water heating and nocturnal radiative cooling in the tropics

## **2.0 MATERIALS AND METHOD**

### **DESIGN OF THE EXPERIMENTAL RIG**

#### **Assumptions**

- ❖ The system is uniformly heated during the day
- ❖ The heating phase occurs for an average of 10hrs from 8am to 6pm.
- ❖ The cooling phase occurs for an average of 10 hours from 8pm – 6am the next day
- ❖ iv. No energy losses from the bottom and edges of the collector

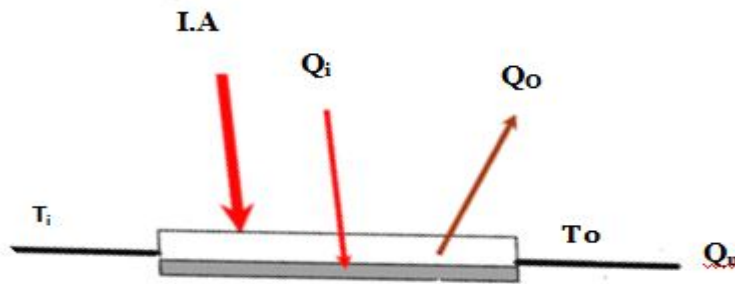
#### **Sizing and Thermal Design of components**

##### **Solar Heating mode**

Average insolation (Monthly) ,**I** for owerri = 4.79kwh/day [13].

Therefore average insolation for the location is

$$I = \frac{4.79 \times 10^3}{8} = 598.75 \text{ W/m}^2 = 599 \text{ W/m}^2$$



**Fig 1.0: Schematic diagram of the Heat flow through a system**

If  $I$  is the intensity of solar radiation, in  $\text{W/m}^2$ , incident on the aperture plane of the solar collector having a collector surface area of  $A$ ,  $\text{m}^2$ , then the amount of solar radiation received by the collector is:

$$Q_i = IA \quad (1)$$

$$Q_i = I(\tau\alpha) \cdot A \quad (2)$$

$$Q_o = U_L A (T_{SCONOR} - T_a) \quad (3)$$

$$Q_u = Q_i - Q_o = I(\tau\alpha) \cdot U_L A (T_{SCONOR} - T_a) \quad (4)$$

$$Q_u = MCp_w (-T_w) \quad (5)$$

This is the heat requirement of the design or Useful heat absorbed by the water

Therefore, for 60 liters of water, the heat requirement is

$$Q_{wh} = 1 \times 60 \times 4200 (65 - 25) = 10,080,000 \text{ joules}$$

According to **Duffie and Beckman [14]**, the efficiency of collector is between 0.4 and 0.6.

Also, **Yiping et al [12]** recorded a peak efficiency of 50% in their work in China, while **Nosa et al [15]** recorded 40% in Warri, Delta state Nigeria. An efficiency of 0.42 was adopted for the design based on its dual mode function.

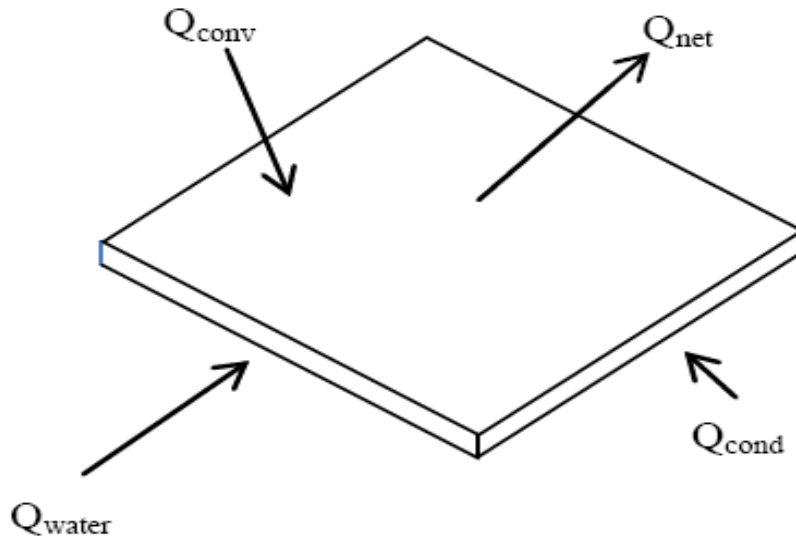
The collector area for the requirement is given by **Ismail et al [16]**

$$A_c = \frac{Q_w}{\eta t I} \quad (6)$$

Where  $A_c$  = Area of the system ( $m^2$ )

$$\begin{aligned} \text{system Area} &= \frac{10,080,000}{0.42 \times 599 \times 8 \times 3600} \\ &= 1.40 m^2 \end{aligned}$$

### Cooling Mode Design Considerations



**Fig 2: Energy Balance on cooling mode [17]**

From Fig 2, heat exchange between the panel and the surrounding, in the water cooling mode during the night, is described with the following expression (17),

$$Q_{water} + Q_{cond} + Q_{conv} = Q_{net} \quad (7)$$

$$\text{Where, } Q_{water} = M_w C_w (T_{in} - T_{out}) \quad (8)$$

This is the heat transferred from the water flowing through the tubes to the system in cooling mode,

$$Q_{cond} = A_{SCONOR} U_{ins} (T_{insulation} - T_{SCONOR}) \quad (9)$$

This is the heat transfer between system and insulation material.

$$Q_{conv} = h A_p (T_a - T_{SCONOR}) \quad (10)$$

Considering a given radiator shown, the heat loss of covered (polyethylene film) night sky radiator related to convection is neglected, because polyethylene film reduces heat gain from air movement **Givoni [18]** ; **Aubrey[19]**. Convective heat transfer depends on the ambient air temperature and wind velocity, which is expressed through the convection heat transfer coefficient  $hc$  **Tiwari and Suneja [20]**.

$Q_{net}$  is the net thermal radiation from the plate to the sky.

Net exchange of Radioactive heat,  $Q_{net}$ , between the system and the Sky is given by [21] as :

$$Q_{net} = \sigma \epsilon A [(T_{system} + 273.15)^4 - (T_{SKY} + 273.15)^4] \quad (11)$$

Energy Balance

$$Q_{net} = LW\uparrow - LW\downarrow \quad (12)$$

Where  $LW\uparrow$  = upward long radiation flux ( $w/m^2$ )

$LW\downarrow$  = downward long radiation flux ( $w/m^2$ )

Expanding equation (11) to evaluate  $LW\uparrow$  and  $LW\downarrow$

$$Q_{net} = \sigma \epsilon A (T_{system} + 273.15)^4 - \sigma \epsilon A (T_{sky})^4 \quad (13)$$

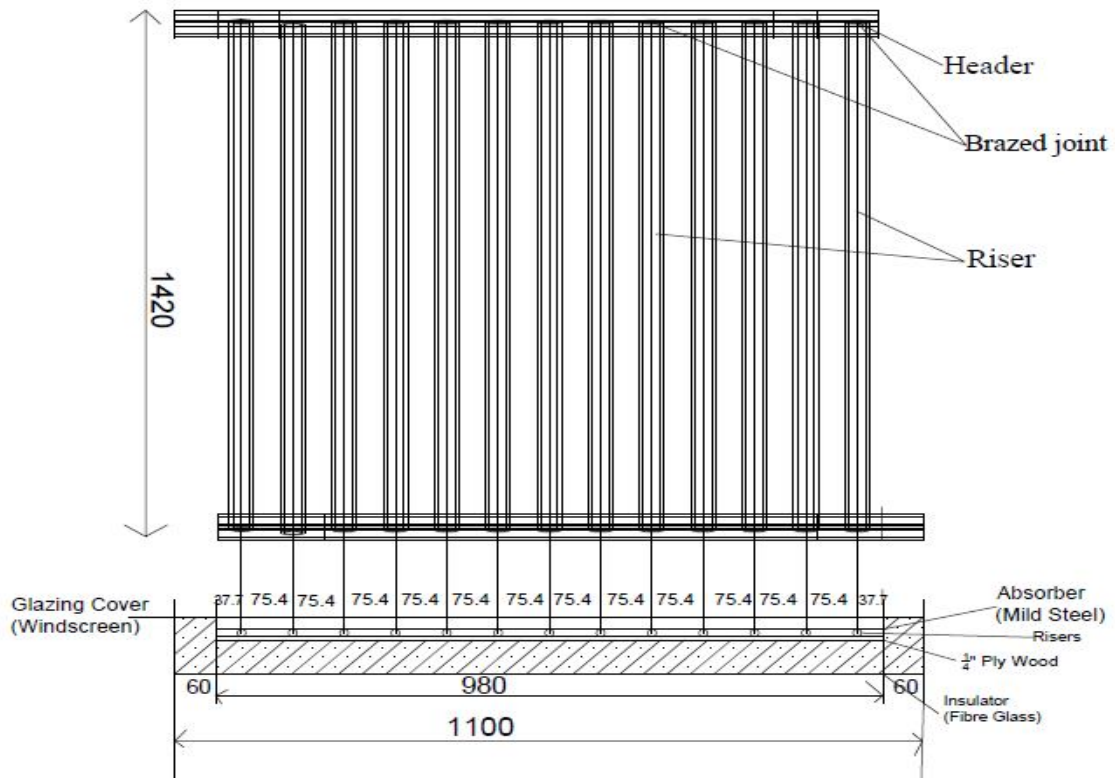
$$Q_{net} = Q\uparrow - Q\downarrow$$

$$\text{Where } T_{sky} = \epsilon_{sky}^{1/4} (T_{amb} + 273) \quad (14)$$

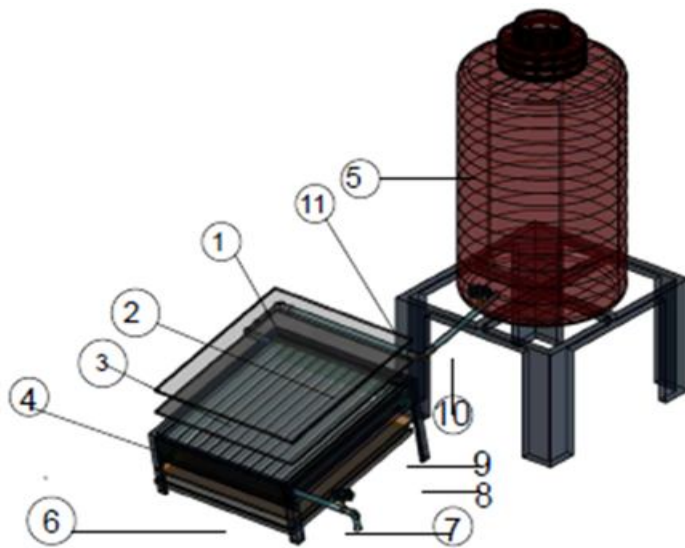
$$\text{And } \epsilon_{sky} = 0.742 + 0.62 \left( \frac{T_{dp}}{100} \right) \quad (15)$$

### 3 DESCRIPTION OF THE COMPONENTS OF system

The absorber plate (hybrid surface), is made of mild steel of thickness 1mm, measuring 1420mm by 980mm (area of 1.4m<sup>2</sup>). Welded beneath the plate is a 1/4 inch copper pipe headers brazed to 13 risers/tubes of 1/2 inch (12.7mm) at a tube spacing of 62.5mm. The system surface is coated with an acrylic resin (spectrally selectivity coating) to make it spectrally selective. A polyethylene windscreen was placed 20mm from the system surface to allow transmission and emission of radiation through the solar and atmospheric window spectra respectively, as well as reduction of wind effects and convection losses. The bottom side of the system is covered with a 100mm; approximately 4-inch fibre glass to reduce heat transfer by conduction.



**Fig 3: Arrangements of headers and riser tubes**



S/N	Description	Materials
1	Glazing Cover	Polyethylene
2	Header Pipe	Copper pipe
3	Riser Pipe	Copper Pipe
4	Absorber	Mild Steel
5	Water Tank	Plastic
6	1/4" Ply Wood	Wood
7	Water Regulator	Casted
8	HHCP Stand	Mild Steel
9	Insulator	Fiber Glass
10	Piping	PVC
11	Water Tank Stand	Mild Steel

**Fig 4: Pictorial view of system with part list**



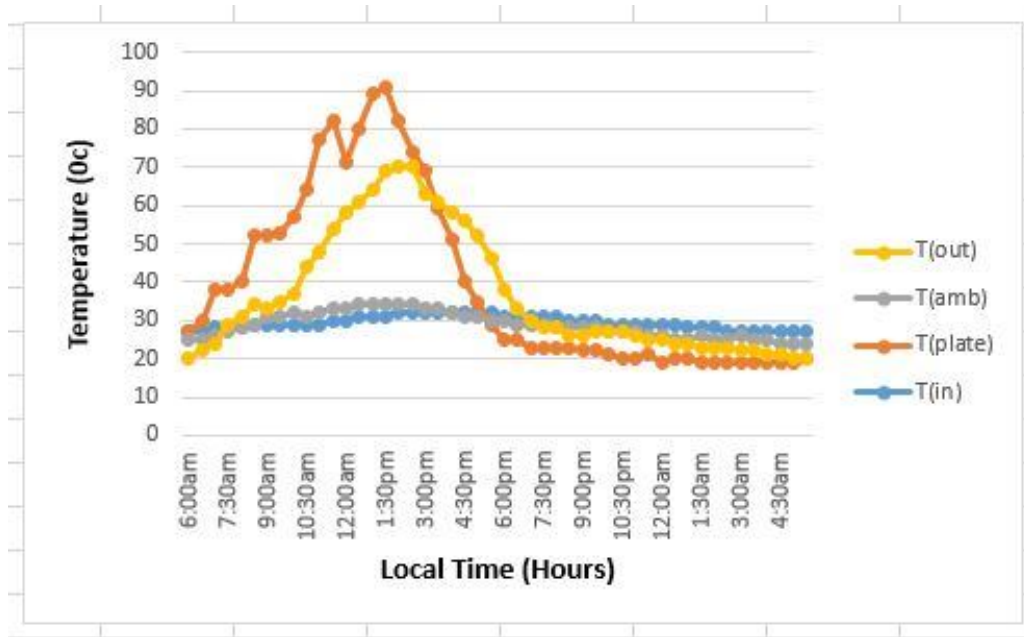
Fig 5 : Experimental rig

## 5.0 RESULTS AND DISCUSSION

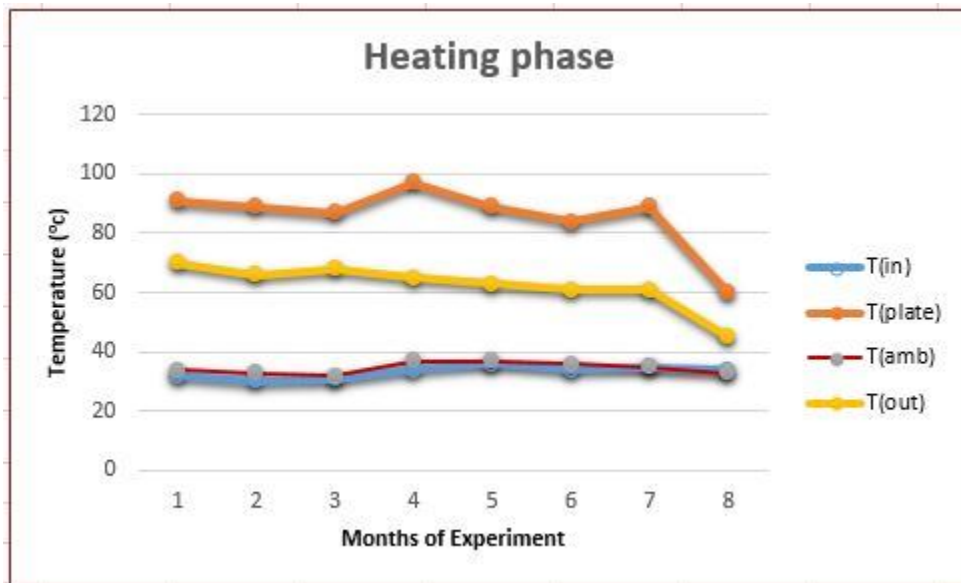
The experimentation on the hybrid solar collector and Nocturnal radiator for passive cooling / heating applications was carried out and monthly average result for a period of eight month was reported. The months of investigation were; October, November, December,2021 and January, Febuary, March, April, and May, 2022. The parameters measured included inlet water temperature ( $T_{inlet}$ ), plate temperatures ( $T_{plate}$ ), exit water temperature ( $T_{out}$ ), ambient air temperature ( $T_{ambient}$ ), and wind speed ( $V_{wind}$ ) both in heating and cooling modes respectively. Also measured during heating mode is the insolation.

Evaluation of parameters in the heating mode comprising total energy absorbed by system ( $Q_i$ ), energy losses from the system ( $Q_o$ ), useful energy absorbed by the system ( $Q_u$ ), efficiency of system ( $\eta$ ), and water temperature rise due to heating ( $T_{out} - T_{in}$ ) as presented. Cooling mode parameters were also evaluated and

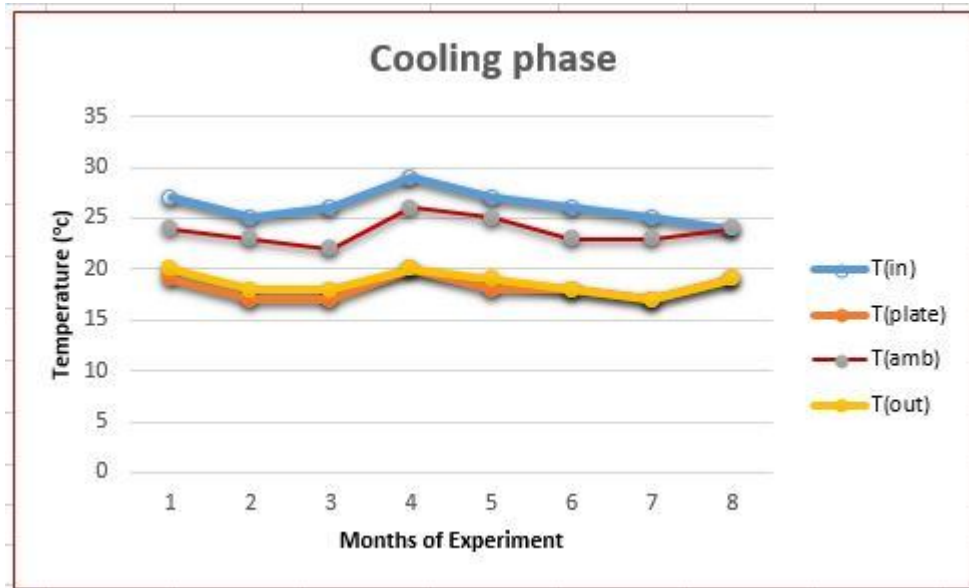
expanded. It comprised of Sky temperature ( $T_{sky}$ ), upward long radiation flux  $w/m^2$  ( $Q_{\uparrow}$ ), downward long radiation flux in  $w/m^2$  ( $Q_{\downarrow}$ ), net outgoing radiation from the plate to the night sky ( $Q_{net}$ ), system temperature and ambient temperature difference.



**Fig. 6** Temperature variation with local time on a test day for Heating and Cooling Phases

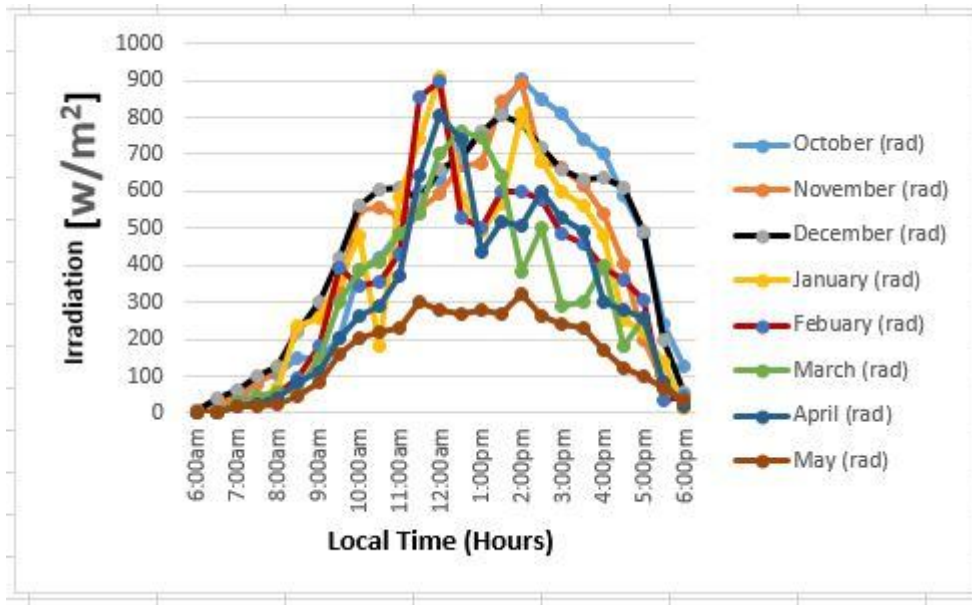


**Fig. 7:** Variations of daily maximum temperature over the experimental period (Heating phase)



**Fig. 8:** Variations of daily maximum temperature over the experimental period (Cooling phase)

Fig. 6, Fig. 7 and 8 show heating mode and cooling mode temperature profile on the system. It can be seen that inlet water,  $T_{inlet}$ , flat plate collector ( $T_{plate}$ ), ambient condition,  $T_{ambient}$ , and outlet water,  $T_{outlet}$  temperatures respectively increases as the insolation increases during diurnal water heating and decreases with sky temperature during nocturnal water cooling. The variations in these temperatures are function of solar radiation for diurnal heating and night sky temperature for nocturnal cooling. The peak solar radiation was found between 12pm and 2pm (see fig.9) at a maximum average water out let temperature of  $60^{\circ}\text{C}$ , plate temperature of over  $90^{\circ}\text{C}$  for the days/months under test during diurnal heating. Cooling mode recorded temperature depression of  $5^{\circ}\text{C}$  at ambient temperature of about  $25^{\circ}\text{C}$ .



**Fig. 9:** Variations of monthly average maximum temperature over the experimental period

The variation of hourly global solar radiation over the experimental period is as shown in Fig 9. The test location recorded maximum solar irradiance on the month of January, followed by October, December, February while May recorded the least insolation due to many rainy days. However, the peak times of occurrence differ. The peak occurred around 12:00 (hours) in January while it occurred around 14:00 (hours) at other periods. As is expected, from April to May, the insolation decreased drastically due largely to the commencement of rainy season associated with the period. Nevertheless, the amount of insolation around the period was as low as  $320\text{W/m}^2$  in the peak hour period (12pm to 2pm), which is still enough to produce domestic hot water (DHW). This means that the devices can function effectively during the rainy season period in the tropical city of Owerri, Nigeria and other locations of similar climatic condition.

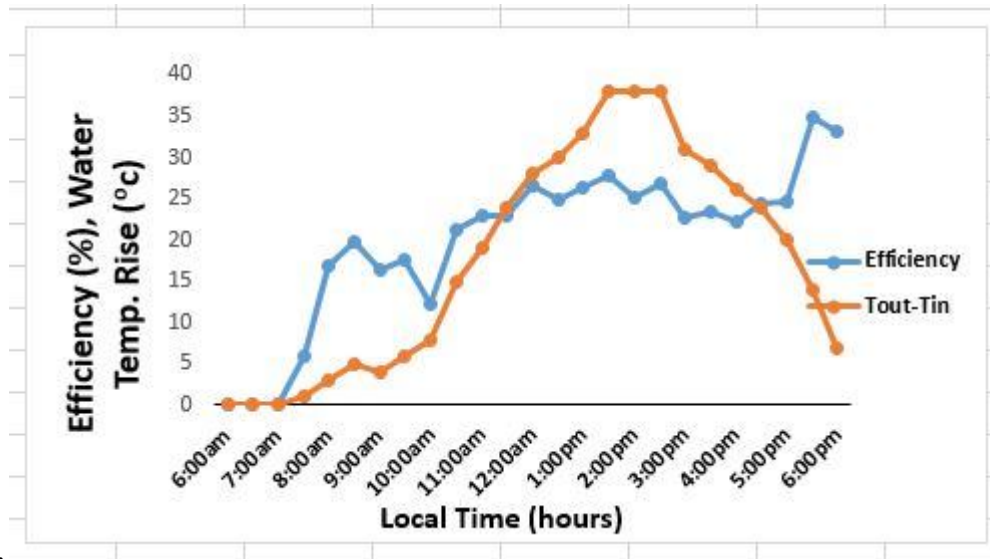
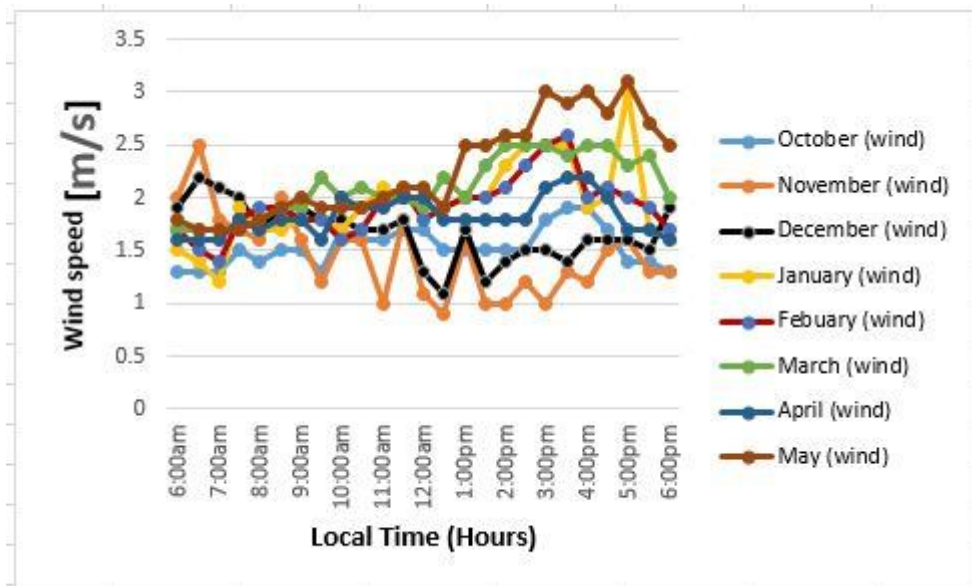


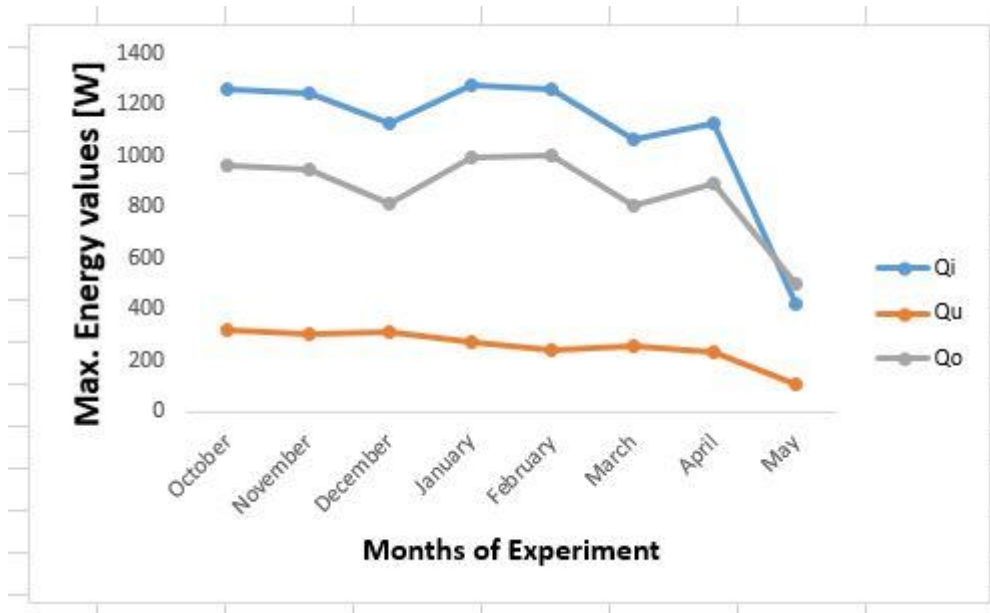
Fig 10: Time Variation of efficiency of system with Water Temperature rise for a test day (heating mode)

The maximum efficiency of the system was 31%, where such values were recorded after noon at lower insolation, see Fig. 10. The efficiency then progressed steadily towards the sunset. Therefore at high radiation, the efficiency was lower while higher at low radiation. This is attributed to high losses due to high energy exchange. Therefore, the efficiency of the collector at low solar radiation is higher than as compared to condition of higher radiation. Collector efficiency as well as cooling power (cooling phase) depend on the value of temperature difference between plate and ambient.

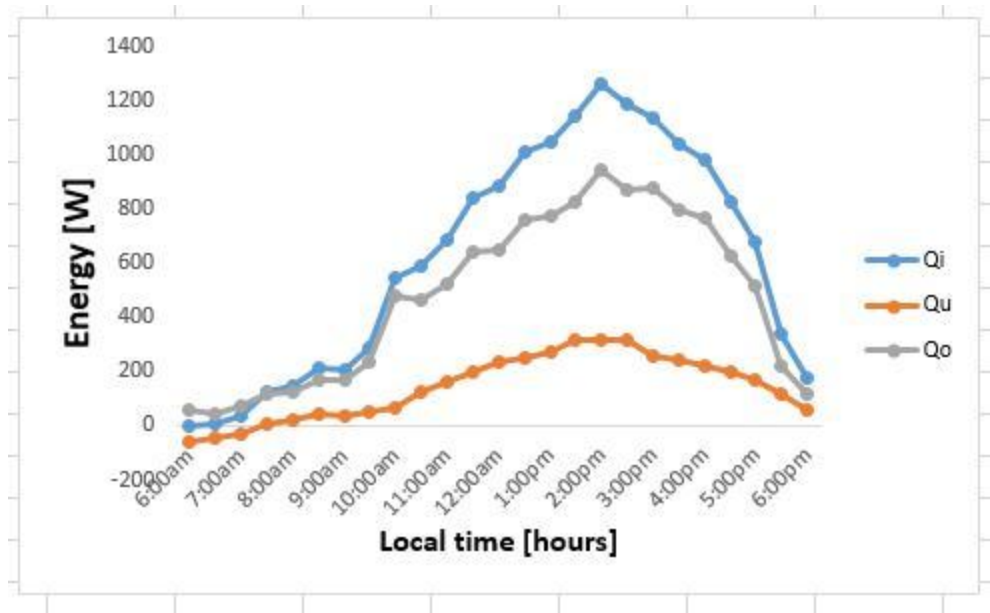


**Fig. 11** Time variation of wind speed over the experimental period

Figure 11 shows variation of wind speed over the experimental period of eight months. Wind speed fluctuated between 1 and 3 m/s within the time under test. At higher wind speeds, higher losses are recorded on the plate due to convection. It can be seen that May was a bit cloudy with low solar radiation. The ambient temperature was also low with more wind speed. This affected the heating result. The periods of high wind intensity correspond to the periods of low irradiation. Therefore, solar intensity largely depends on the prevailing wind speed in any particular location. The thermal efficiency is not only affected by the intensity of solar radiation, but wind velocity also. It may be concluded that the efficiency of the system at low wind speed is higher than as compared to the condition of high wind speed, for both heating and cooling. This is due to the reason that, with the increase in wind velocity the convective heat loss to environment increases.



**Fig. 12** Variation of thermal energy over the experimental period (Heating phase)



**Fig. 13** Energy variation with time on a test day (Heating phase)

From Fig. 12 and 13, the peak useful energy of over 300 (watts) into the fluid system was recorded at peak solar radiation under heating. Although Fig. 12

reveals that the system received the highest incident global radiation in January, yet the best performance was recorded in December. It is evident that the system was associated with high rate of losses which affected the useful energy reported. The mild steel used as a substrate is known to have a low energy collection efficiency, coupled with the fact that it was coated with only acrylic resin. For a given rate of solar insolation, the collector efficiency increases with decreasing differences between the plate and the ambient temperature. However, the results obtained for the eight months show that the system is capable of providing needed output for optimum water heating throughout the year.

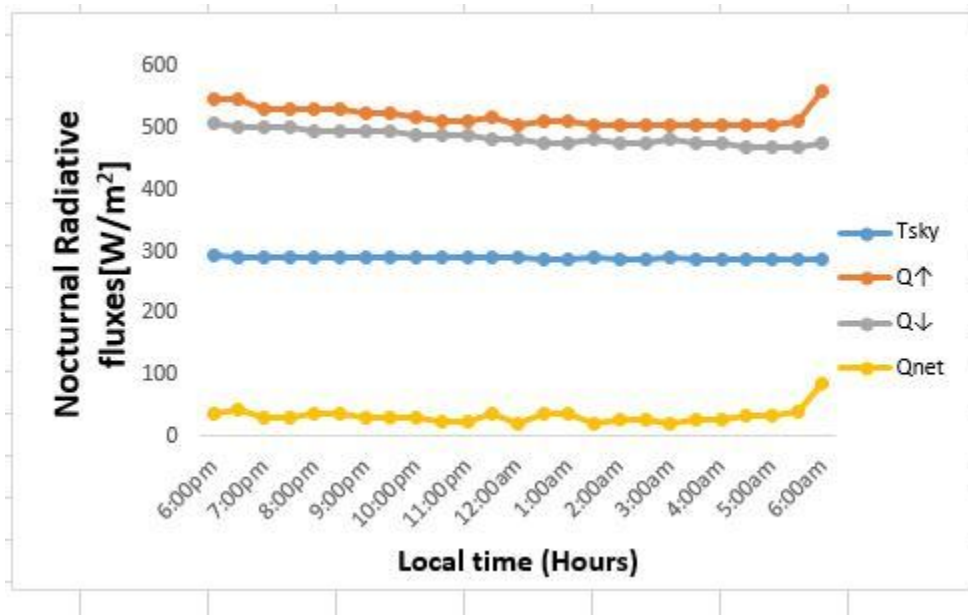


Fig 14: Time Variation of Nocturnal radiation fluxes for test day

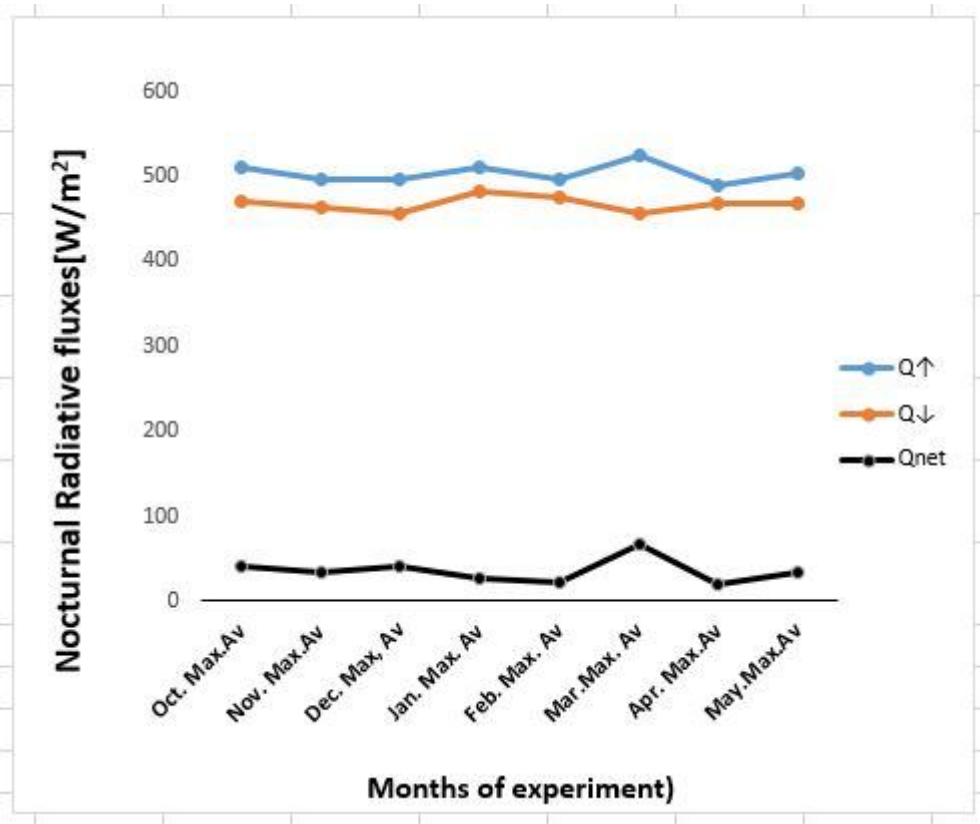


Fig 15: Variation of Nocturnal radiation fluxes during experimental period (Cooling phase)

Figs 13 and 14 are graphs showing variations of upward long radiation flux ( $Q\uparrow$ ), downward long radiation ( $Q\downarrow$ ) and outgoing radiation from the plate to the night sky ( $Q_{net}$ ) during cooling for the days/months tested. A radiator can only provide with practical cooling only when the upward long radiation flux ( $Q\uparrow$ ) exceeds the downward long radiation ( $Q\downarrow$ ). The system satisfies the condition as a practical nocturnal radiator as seen on the graphs. An average cooling power of  $41\text{W/m}^2$  was obtained on cloudless days and about  $20\text{W/m}^2$  on cloudy days of May. Also, the sky temperatures were lower than the ambient temperature. This is prerequisite for nocturnal cooling. The sky temperature has to be lower than ambient

temperature if the sky is to function as a heat sink. This thus, makes it possible for the sky to absorb the heat radiated away by objects on the earth since heat flows from areas of higher temperatures to those of lower temperature. The sky temperature ranges between 10°C to 16°C for the period under study. Also, for cooling, the best performance was recorded in the month of March (after harmattan) at 5°C temperature depression and the result was consistent except on cloudy days. **Result compares favorably with those in the literature.**

## **CONCLUSION**

The system in Heating mode recorded maximum water temperature rise of 30°C at ambient temperature range of 27°C -35°C, and a maximum water temperature of about 60°C at heat collecting efficiency of 31% at peak insolation (600W/m<sup>2</sup> - 900W/m<sup>2</sup>) and plate temperature of over 80°C except for cloudy/rainy month like May.

The system in Cooling mode recorded an average cooling power of about 41w/m<sup>2</sup> in clear sky and as low as 20w/m<sup>2</sup> in cloudy sky. The clear night results represent results for most of the night during dry season while results on cloudy sky represents results for most of the nights during wet season. During cooling, the water temperature was cooled down to as low as 19°C on a clear sky, with a temperature depression of about 5°C below ambient. The night sky temperature of the location Federal Polytechnic Nekede was obtained in the range 10°C to 16°C for the period under study.

The obtained result satisfies: domestic Hot/ cold water, Comfort heating / cooling.

Given the flexibility of the system to be integrated into building structure, there is significant potential for energy savings for buildings in Owerri, Nigeria and other locations of similar climatic conditions.

**Future research shall be on the exergy studies of the system to minimize energy loses.**

## **Reference**

1. Toosi, R. (2010) Energy and environment “choices and challenges in a changing world”. Verve publishers inc, L.A, USA pp409
2. Nwaji, G.N., Okoronkwo, C.A., Ogueke, N.V., & Anyanwu, E.E. (2020). Investigation of a hybrid solar collector/nocturnal radiator for water heating/cooling in selected Nigerian cities. *Renewable Energy*, 145, 2561-2574.
3. Mong, O.O., Nwaji, G.N. and E.E. Anyanwu (2020) Experimental Investigation of the Diurnal Phase of Hybrid Water Heating/Nocturnal Cooling Flat-Plate Solar Collector in Owerri, Nigeria. *International Journal of Engineering Inventions*: 2319-6491 Volume 9, Issue 1 PP: 01-08
4. Granqvist, C.G.(1989). *Spectrally Selective surfaces for heating and cooling applications*. SPIE Opt. Engr. Press, Bellingham, USA.
5. Mingke, H., Pei,G., Li,L., Zheng,R., Li,J., and Ji1, J. (2015). Theoretical and experimental study of spectral selectivity surface for both solar heating and radiative cooling. Hindawi Publishing Corporation International Journal of Photoenergy Vol 2015. <http://dx.doi.org/10.1155/2015/807875>
6. Erell, E. & Etzion, Y. (2000) Radiative cooling of buildings with flat-plate solar collectors. *Building and environment*, 35(4), 297-305.
7. Balen, I., Soldo, V., & Kennedy, D. (2003). Analysis of cooling and heating of water with flat-plate solar radiators. *Proceedings of Conference on Sustainable Developments of Energy, Water and Environmental Systems*, Dubrovnik, Croatia.
8. Alorma, J. & Kiss, L.I. (1988). Solar heating and radiative cooling using an uncovered flat-plate collector under Syrian climate. Institute of Thermal and Systems Engineering ,Technical University H-1521, Budapest
9. Hosseinzadeh, E .,& Taherian, H.,(2012) An experimental and analytical study of a radioactive cooling system with unglazed flat plate collectors. *International Journal of Green energy*. 9: 766-799
10. Anderson,T.N., Duke M.,& Carson J.K. (2013). Performance of an unglazed solar collector for radiant cooling. *Proceedings of Australian Solar Cooling 2013*, Sydney.
11. Matsuta, M., Terada, S. & Ito,H. (1987). Solar heating and radiative cooling using a solar collector-sky radiator with a spectrally selective surface. *Solar Energy*, 39(3), 183–186
12. Yiping, W., Yong, C., Li, Z., & Jianguo, K., (2007). Thermal performance analysis of a solar heating and nocturnal radiant cooling system. *Proceedings*

- of 548 ISES Solar World Congress 2007: Solar Energy and Human Settlement pp545-550
13. National Aeronautic and Space Administration (NASA), (2002) Meteorological data for Owerri
  14. Duffie, J.A. & Beckman W.A. (2013) Solar Engineering of Thermal Processes, Fourth edition. New Jersey: Wiley Hoboken.
  15. Nosa, A.O., Ikponmwo, O., & Julius, J. (2013). Design and construction of a solar water heater based on the thermosyphon principle. Journal of Fundamentals of Renewable Energy and Applications 3(2013), Article ID 235592, 8 pages doi:10.4303/jfrea/235592
  16. Ismail, I.R.; Mohammad, B.A.; Mohammad, H.I.; Mahmoud, M.G. & Mohammed, K.H. (2015). Design, Construction and Installation of 250-liter capacity solar water heating system at Danjawa renewable energy model village. International Journal of Engineering Sciences 4(3), 39-44
  17. Ogueke, N. V., Onwuachu, C. C. & Anyanwu, E. E. (2011). Experimental study of long-wave night sky radiation in Owerri, Nigeria for Passive Cooling Application. World Renewable Energy Congress, Low Energy Architecture. Linköping, Sweden.
  18. Givoni, B. (1994). Passive low energy cooling of buildings. John Wiley & Sons. Van Nostrand Reinhold Co, New York.
  19. Aubrey, J. (2006). radiative cooling in hot humid climates. MIT  
<https://www.people.csail.mit.edu/jaffer/cool/cool.pdf>
  20. Suneja, S., Tiwari, G., & Rai, S. (1997). Parametric study of an inverted absorber double-effect solar distillation system. Desalination, 109(2), 177-86
  21. Fernandez, N., Wang, W., Alvine, K.J., & Katipamula, S. (2015). Energy savings potential of radiative cooling technologies. Pacific Northwest National Laboratory (PNNL), Richland, WA (US)