

## **Original Research Article**

# **DESIGN AND DEVELOPMENT OF PULL TYPE BATTERY OPERATED MULTI-CROP PLANTER FOR WOMAN FARMERS IN TRIBAL REGION OF GUJARAT**

## **ABSTRACT**

In tribal region of Gujarat women are the integral part of the farming system. They transform mostly all kinds of work. Manual seed sowing consumes much energy as well as time. For maintaining uniformity in planting seed to seed distance should be accurate. Most existing manual seed sowing devices don't have this facility. To provide a better option, a multi-crop planter was developed with electric metering at College of Agricultural Engineering and Technology, Godhra for woman farmer in tribal region of Gujarat. Multi-crop planter consists of main frame, handle, furrow opener, seed tube, marker, metering mechanism, DC battery (12V), DC motor, DC speed regulator, switch and DC charger. The payback period of developed machine was found as 53.42 hours on hour basis and 6 ha on hectare basis. The benefit cost ratio of the developed multi-crop planter was found as 14.97 over a period of 10 years of the life of the multi-crop planter.

**Keywords:** *Seed sowing, seed metering, multi-crop planter, DC battery, DC motor*

## **INTRODUCTION**

There are around 74 per cent farmers, who are small and marginal, having less than 2 ha land in India (Economic survey of India 2010-11). A variety of planting equipment and machines are available which are tractor drawn, animal drawn, and manual operated seed drills/planters etc. Tractor operated seed drills/planters are suitable for big farmer and big field. Keeping bullocks is becoming more costly for small farmers. In the broadcasting methods, it is not possible to achieve uniformity in seed distribution and poor emergence of crop due to uneven depth of sowing seeds. In agricultural sector woman plays a vital role, because it is largely a household enterprise. Especially for small farmers, nearly 78 per cent of women are engaged in agriculture as compared to 63 per cent of men. Almost 50 per cent of rural female workers are classified as agricultural labourers and 37 per cent as cultivators. About 70 per cent of farm works are performed by women. It is observed that women play a significant and crucial role in agricultural development and allied fields including, main crop

production, live-stock production, horticulture, post-harvesting operations, agro/social forestry, fishing etc. (Rao, 2006)

Traditional manually operated planter has mechanical metering mechanism Bandhiya *et al.* (2016), Ghosal and Sarkar (2013) and Singh *et al.* (2013). This metering mechanism is driven by ground wheel. Due to the soil resistance and mechanical transmission the ground wheel slips or skids. It causes the seed loss and non-uniforming in seed spacing. In other hand this mechanism also increases the weight of the manually drawn planter Indra Mani *et al.* (2006), Sahoo and Srivastava (2008), Reddy *et al.* (2012) and Reddy and Adake (2013). Further it requires more amount of power to pull the planter, but the power availability of the human worker is limited. With the aim to reduce weight of planter as well as to get precise crop spacing battery operated metering mechanism would give better result. Battery operated metering mechanism may be one of the options to achieve accurate seed spacing and reduce draft of the operational speed without affecting to the worker's comfort Rajaiah *et al.* (2018) and Lende *et al.* (2011). Therefore, the project been under taken as 'Design and Development of pull type battery operated multi-crop planter for woman farmers in tribal region of Gujarat'.

## MATERIALS AND METHODS

### DEVELOPMENT OF VARIOUS COMPONENTS OF THE MULTI-CROP PLANTER

Development of multi-crop planter was carried out on the basis of power availability, number of rows, type of seed metering mechanism, hopper size etc.

In design and development of the manually operated pull type battery operated multi-crop planter, the basic emphasis was given on simplicity of fabrication, use of locally available material and low cost. Ease of assembling and dismantling for repairs and inspection were also considered. The manually operated multi-crop planter consisted of wooden frame, seed hopper, seed metering unit, seed tube, furrow opener, and handle.

#### 1. Power Requirement of Multi-Crop Planter

For 8 hours work the power developed by the human operator is 0.06 – 0.11 hp. Taking it into consideration, the power developed for the women is about 0.06 hp, due to lower physical strength as compared to male-workers. (Sharma and mukesh, 2013)

$$\text{hp} = \frac{\text{Draft(kgf)} \times \text{Speed (m/s)}}{75}$$

Let the operating speed of machine be 2 km/h. or 0.555 m/s.

$$\begin{aligned} \text{Draft (kgf)} &= \frac{\text{hp} \times 75}{\text{Speed} \left(\frac{\text{m}}{\text{s}}\right)} \\ &= \frac{0.06 \times 75}{0.555} \\ &= 8.11 \text{ kgf} \end{aligned}$$

Draft developed by an average woman worker = 8.11 kgf.

## 2. Size and number of furrow opener suitable for the planter

Using the triangular shovel type furrow opener with wooden tine,

Draft of single furrow = Soil Resistance  $\times$  Cross Section area

$$= 0.6 \times \frac{1}{2} \times (5 \times 5)$$

$$= 7.5 \text{ kgf}$$

Max. Soil resistance for tilled soil =  $0.6 \text{ kg/cm}^2$

$$z = \frac{\text{Draft of planter (kgf)}}{\text{Draft of each row (kgf)}}$$

Where, Z = number of furrow openers in the planter

D = Draft requirement of planter, kgf

d = Draft of each row, kgf (7.5 kgf for shallow depths)

$$Z = \frac{8.11}{7.5} = 1.081 \approx 1.0 \text{ (single row planter)}$$

The implement was designed for sowing of one row.

## 3. Design of Seed Hopper

For designing the seed hopper, bulk density and angle of repose of maize, groundnut and gram seeds were considered. The average bulk density of maize, groundnut and gram seeds was 722, 660, 748  $\text{kg/m}^3$  respectively and the angle of repose was  $28^\circ$ ,  $26^\circ$ ,  $31^\circ$  respectively. Therefore, to facilitate the smooth flow of seeds under the gravitational force towards the metering mechanism, the angle of the hopper side wall was kept  $35^\circ$ . The overall capacity of the hopper was kept to store 3 kg of seeds. The volume of the hopper was determined on the basis of lowest average bulk density of the seeds.

$$V_b = 1.1 \times \frac{W_s}{\gamma_s}$$

Where,  $V_b$  = volume of seed hopper,  $\text{cm}^3$

$W_s$  = Mass of seed in the hopper, g

$\gamma_s$  = Bulk density of seeds,  $\text{g/cm}^3$

$$\text{Volume of hopper} = 1.1 \times \frac{\text{Capacity of the hopper}}{\text{Bulk density of seed}}$$



The metering mechanism used in the prototype was an inclined plate metering mechanism. The inclined plate metering was chosen over other types due to the following facts: (Donnel Hunt, 2001).

1. The cells provide efficient metering of seeds.
2. Breakage of seeds was found minimum.

The metering unit consists of the seed metering plate casing, the shaft to rotate the metering plate, 12 V, 60 rpm DC motor and the seed delivering pipe. The seed metering plate casing, made up of MS sheet was fitted to the hopper by the means of nuts and bolts. A Shutter was provided in front of metering mechanism for adjusting seed movement towards metering mechanism. The diameter of 40 mm round hollow M. S. pipe of 50 mm length was provided for proper delivery of the seed to the seed tube. Aluminum alloy shaft was fitted to the casing and the metering plates were fitted to it by means of screw lock. The other end of the shaft was connected to the shaft of the motor, which gives drive to the metering plates. Battery and motor speed regulator was fitted on hopper with nut-bolts. One switch was provided on handle for switching the metering mechanism.

#### **a. Metering unit**

A metering unit was developed by the use of inclined plate metering mechanism. The inclined plate was revolved by the use of a variable speed, high torque DC motor. The speed of the motor can be manually varied by an external knob to maintain the rpm of the motor which in turn gives accurate seed to seed spacing. By this method seeds can be efficiently metered and planted easily.

Rpm of the metering plate for required seed to seed spacing is calculate by

$$\text{Required rpm} = \frac{\text{forward speed of opretion (m/min)}}{\text{reuired seed spacing(m) X no. of groove on roller}}$$

RPM was calculated for seed spacing of 10 cm for groundnut, 15 cm for gram and 20 cm for maize crops.

#### **b. Seed metering plate**

It is the most important part of the planter as it meters the seed. For better sowing of seed each cell should be packed with a single seed in such a way that it does not get ejected by the cell. Seed packing is greatly affected by the relationship between the cell size and thickness of the seed. Keeping this into consideration an appropriate cell feed mechanism was made of plastic with the diameter of 100 mm. The dimensions of each cell were decided by considering the dimension of the seeds.

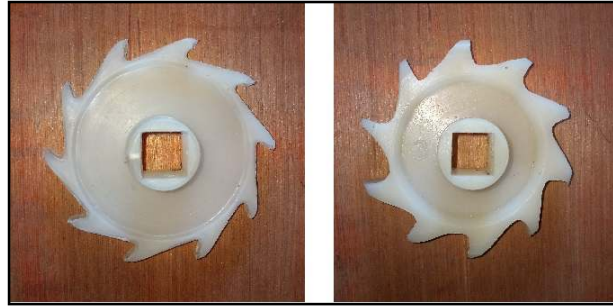

**Fig. 2 Metering plate**

On the basis of the physical dimensions of groundnut, maize and gram two sizes of seed metering plates were used. The diameter of the metering plates was 100 mm each. Seed metering device had a rotor with cells on its periphery. It was made of plastic. The cell has 10 mm depth and 20 mm tapered length along the periphery of cell. The metering plate was procured and the cells on peripheral were reshaped for free dropping of seeds in seed tube.

### c. Metering shaft

Metering shaft was developed by turning a square rod of 15 mm x 15 mm into round shaft. The total length of metering shaft was 90 mm. The detailed dimension of the metering shaft is shown in Fig. 4



**Fig. 3 Metering shaft**

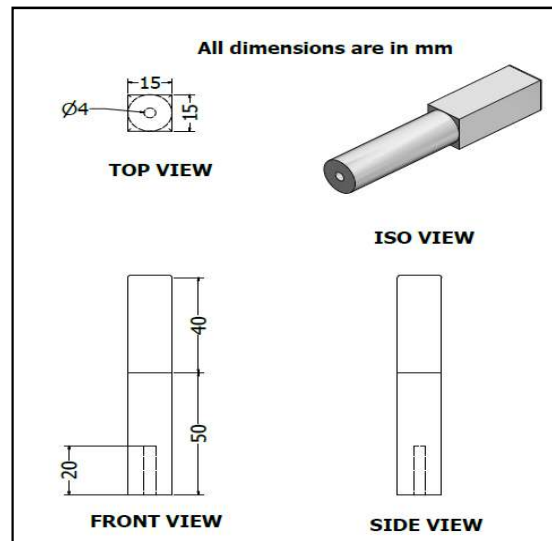

**Fig. 4 Detailed drawing of metering shaft**

## 5. Power Source for Metering Mechanism

The drive to the seed metering plate was provided by means of a 12V 60 rpm DC motor, which was powered by the, rechargeable DC battery (12V-1.3 amh).

**a. DC motor**

DC motor was used to drive the metering mechanism. Torque requirement for rotate the metering mechanism was measured in laboratory using the pulley having diameter of 10 cm. Pulley with string and a pan was fitted at the end of the shaft. In the pan known mass was increased gradually and mass was noted down. Torque was calculated as

$$\text{Torque (kgf-cm)} = \text{Max. Mass in pan (kgf)} \times \text{Radius of pulley (cm)}$$

Torque was found 0.6 kg-cm take the factor of safety 2 then torque was 1.2 kg-cm as per market availability taken the 1.5 kg-cm torque motor was selected. DC motor was fixed with the side of the seed box by using small case. Shaft of DC motor was directly fitted at the end of metering shaft through drilled hole. Detailed specifications and dimensions are given Table 1 View of DC motor is shown in Fig 5

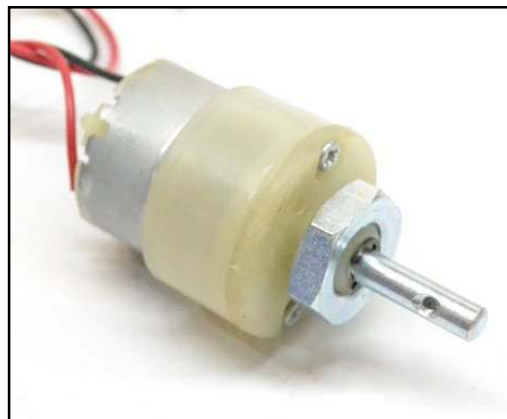

**Fig. 5 DC Motor**

**Table 1: Specification of DC motor is given below**

Name	Specification
Type	Geared DC
Operating Voltage	12 V
Current	60 mA (No-load Current) 300 mA (load Current)
Rpm	60 rpm
Stall Torque	1.5 kg.cm

**b. DC battery**



**Fig. 6 DC battery**

Battery is the main source of power for the metering mechanism. A 12 V DC rechargeable battery was selected for metering mechanism.

$$\begin{aligned} \text{Battery capacity in Ah} &= \text{Battery running time in h} \times \text{Load current in A} / 0.90 \\ &= 4 \times 0.3 / 0.90 \\ &= 1.3 \text{ Ah} \end{aligned}$$

As per market availability 1.3 Ah, 12 V, DC rechargeable battery was selected. Detailed specifications are given in Table 2 and view of battery shown in Fig 6.

**Table 2: Specification of DC battery is given below**

Name	Specification
Type	Rechargeable DC
Voltage	12 V
Amp	1.3 ah

**3.4.4.3 DC motor speed regulator**



**Fig. 7 Speed regulator**

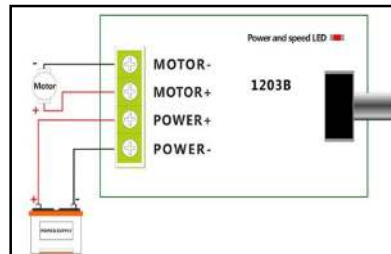

**Fig. 8 Wiring diagram**

Speed regulator was used to regulate rpm of the motor. Change in rpm of metering plate is required to achieve different seed spacing. Rpm can be varied from 5% to 100% of rated speed. Detailed specifications are given in Table 3 and view of speed regulator is shown in Fig. 7 and wiring diagram in Fig. 8.

**Table 3: Specification of DC motor speed regulator is given below**

Name	Specification
Type	DC
Operating Voltage	6-28 V
Current	3 A
Power	80 W

**c. On-off switch**



**Fig. 9 On-off switch**

On-off switch was provided to regulate the power supply of the motor. It was fitted on handle with view to operate easily during operation.

#### **d. DC battery charger**



**Fig. 10 DC battery charger**

DC battery charger was provided to recharge the battery. Battery can be easily connect to the charger for recharging.

#### **6. Seed Tube**

It conveys the seeds from the hopper through metering device to the furrow opener. The motion of the seed takes place due to gravitational force. The aerodynamic properties, friction, impact of the seeds on the wall of seed tube, design features and dimensions of the tube determine the motion of the seeds. For practical purpose, it is difficult to consider all the above parameters. Therefore, the motion of seeds was assumed as a free falling body.



**Fig. 11 Seed tube**

The uniformity of seed distribution, along and across the rows, is influenced by the seed tubes. Therefore, it is highly essential that the seed tubes are maintained in proper operating condition as any bend pinching or surface contamination would lead to non-uniform distribution of the seeds. A transparent PVC tube with an inner diameter of 32 mm was selected. The length of seed tube was kept 250 mm.

### **7. Furrow Opener**

The furrow openers play an important role in providing proper seed placement depth especially under minimum tillage conditions in the soil. Soil type plays an important role in the selection of furrow openers. A hoe type wooden furrow opener was used in the prototype. The furrow opener was placed just below the seed tube and at a minimum height to decrease the seed drop height which in turn ensure free fall of seeds, leading to proper seed to seed spacing.

A triangular shovel type furrow opener with wooden tine was selected. The detailed dimension of furrow opener is shown in Fig. 13.

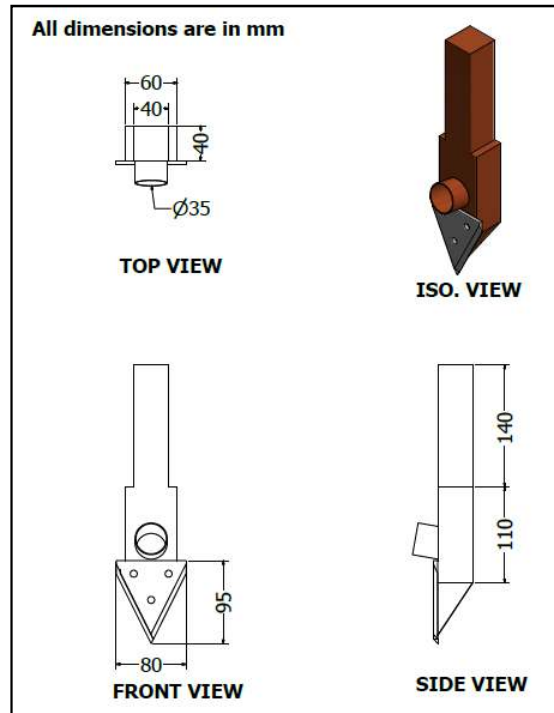

Fig. 12 Detail drawing of furrow opener

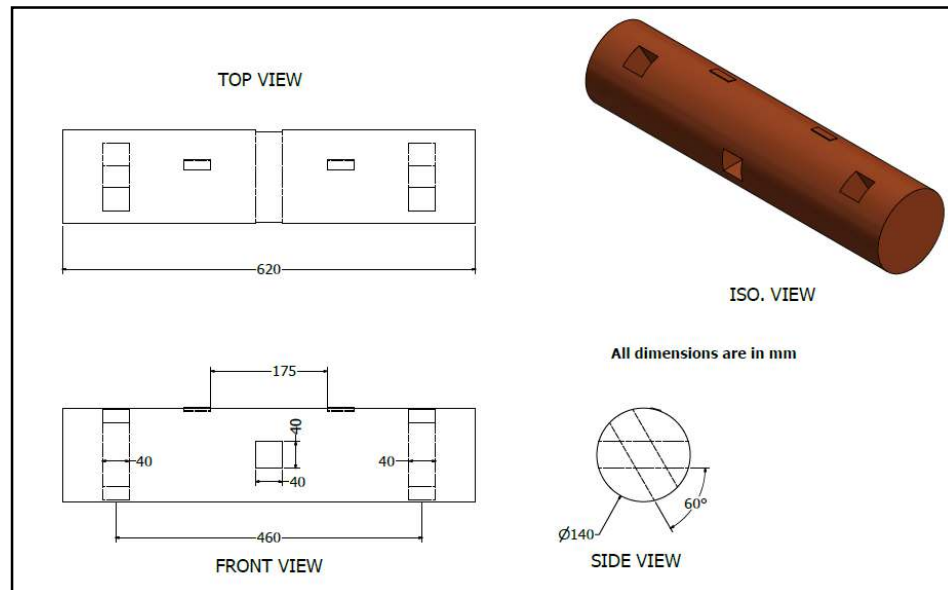
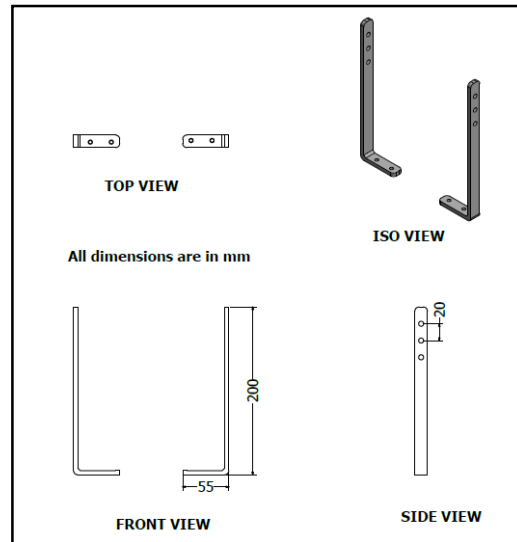

Fig. 13 Detail drawing of main frame



**Fig. 14 Detailed drawing of stand**

### 8. Main Frame

The frame constitutes the main structure of the unit. Frame was made up from cylindrical wooden piece having diameter of 140 mm. length of the frame was kept 620 mm. Two stands were placed on the frame to give support to the hopper and adjustment to the hopper unit for setting the angle to meet the different angle of repose requirements for various seeds.

### 9. Handles

Handles were made to pull and control the multi-crop planter.

#### a. Pulling handle

A bamboo handle was provided to pull the multi-crop planter by operator. The handle was made from bamboo having diameter of 40 mm. Handle was fastened in main frame. The length and width of handle were 1815 mm and 460 mm respectively (Fig. 15).

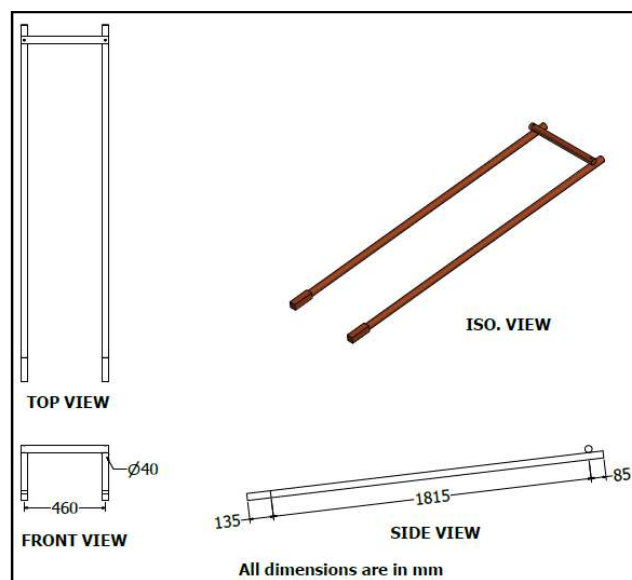

**Fig. 15 Detail drawing of pulling handle**

### b. Controlling handle

Controlling handle was made to carry up and to move the multi-crop planter in the field while performing sowing operation. Controlling handle was made up of MS round pipe. Controlling handle was fixed on wooden frame by using nails. Diameter of controlling handle was 25 mm, Length of controlling handle was kept 650 mm and the upper end of the handle was bend enough to hold easily by the operator.

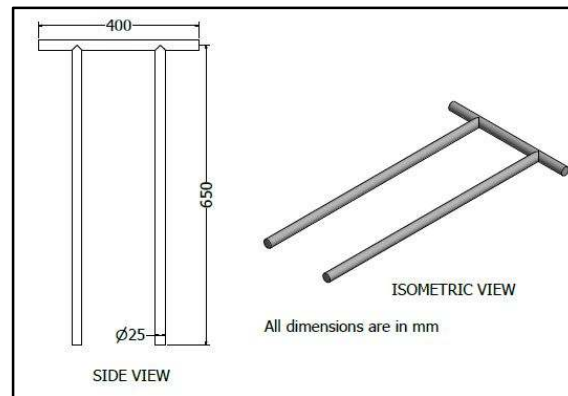

**Fig. 16 Detail drawing of controlling handle**

### 10. Marker

Marker was made up of M.S. flats. Marker was provided to mark distance of next row according to different row to row spacing.

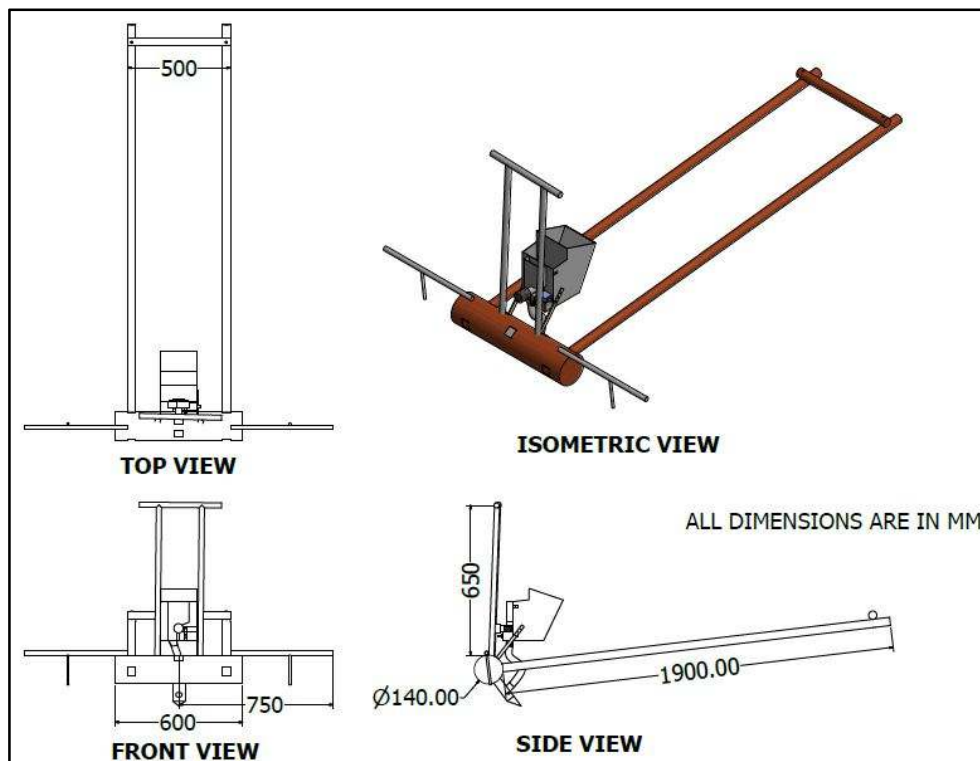

**Fig. 17 Detail drawing multi-crop planter**

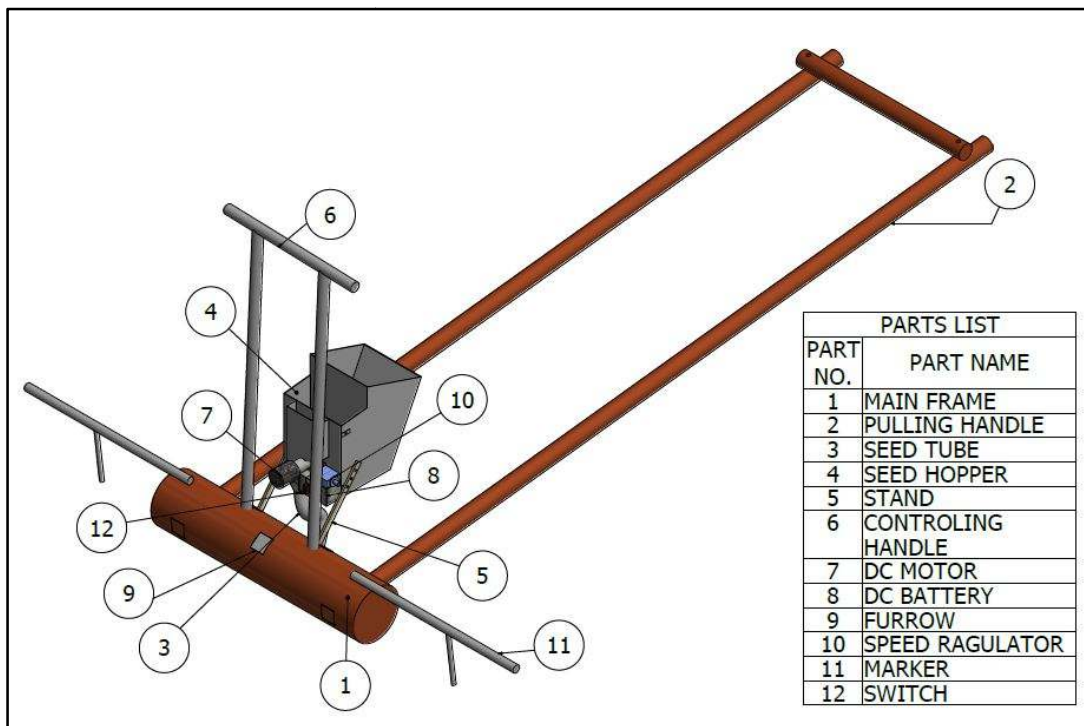

**Fig. 18 Isometric view of multi-crop planter**



**Fig. 19 View of multi-crop planter**

## TECHNO ECONOMICAL EVALUATION OF THE DEVELOPED MULTI-CROP PLANTER

### 1. Payback Period of Developed Multi-crop Planter

The payback period of developed multi-crop planter on hour and hectare basis was worked out based on relationship of annual use of working hours, total benefits, and total manufacturing cost and net benefits. The payback period was expressed by the relation given below.

$$\text{Payback period} = \frac{\text{Initial investment}}{\text{Average net benefit}}$$

Where,

Average net benefit (₹) = (Custom hiring rate, ₹/h - Total operating cost ₹/h)

Custom hiring rate, ₹/h = (Cost of operation of planter per hour + 25 % Overhead Charge) + 25 % profit over new cost

When the above parameters are expressed in hectare, the payback period can be determined on hectare basis.

### 2. Benefit: Cost Ratio of Developed Multi-Crop Planter

It indicates the benefit of the planter over a period of life of that planter. The benefit: cost ratio was worked out by the following formula.

$$\text{B: C Ratio} = \frac{\text{Total benefit}}{\text{Total cost of investment}}$$

Where,

Total benefit (₹) = Average annual net benefit (₹) x Life of planter (years)

Total cost of investment = Initial cost of planter (₹)

## RESULTS AND DISCUSSION

Design and development of multi-crop planter was carried out on the basis of power availability, number of rows, type of seed metering mechanism, hopper size etc. The manually operated multi-crop planter consisted of wooden frame, seed hopper, seed metering unit, seed tube, furrow opener, and handle. It was fabricated from locally available material and low cost. Assembling and dismantling for repairs and inspection is also very easy. This multi crop planer is become light in weight due to wooden frame and battery operated metering mechanism instead of heavy iron base ground wheel. Due to light weight and compact design, its transportation is become very convenient. Woman farmer can operate this multi crop planter without any trouble during field operation.

## TECHNO-ECONOMIC FEASIBILITY OF DEVELOPED MULTI-CROP PLANTER

### Cost Analysis

#### 1. Cost of operation

The cost of operation of the developed multi-crop planter in term of per hectare and per hour was determined considering fixed and variable cost with the help of straight line method. Variable cost includes wages of tow operator as ₹ 500 for a man-day. The cost calculation by straight line method is given in Table 4. The total cost of multi-crop planter, total fixed cost, variable cost and cost of operation is ₹ 2065, ₹ 4 and ₹ 65.08.

**Table 4 Cost calculation by straight-line method**

Sr. No.	Particular	Multi-crop planter	
<b>A</b>	<b>Fixed cost</b>		
1	Initial cost, ₹	2065	
2	Salvage value, ₹	206.5	
3	Depreciation, ₹/h	2.32	
4	Interest, ₹/h	1.42	
<b>Total fixed cost, ₹/h</b>		4.00	
<b>B</b>	<b>Variable cost</b>		
1	Repair and maintenance, ₹/h	2.58	
2	Wages of two operator, ₹/h	63	
<b>Total variable cost, ₹/ha</b>		65.08	
<b>Total cost of operation</b>		₹/h	69.08
		₹/ha	611.35

#### 2. Payback Period of Developed Machine

The payback period is the point in the life of developed multi-crop planter at which the initial or invested cost of multi-crop planter is received and benefit starts. It is found on the hour or hectare basis.

The payback period in case of developed multi-crop planter was found as 53.42 hours on hour basis and 6 ha on the hectare basis. It showed that investment of the machine will be received back in 53.42 hours of its use. On other word, we will get the total investment of the multi-crop planter will be equal offer 6 ha of its use.

#### 3. B: C Ratio

The benefit cost ratio indicates the benefit received by purchasing any multi-crop planter over its total working life. The benefit cost ratio in case of the multi-crop planter was found as 14.97 over a period of 10 years of the life of the multi-crop planter. (Varshney *et al.*, 2004)

## CONCLUSIONS

The developed multi crop planter is very useful for small farmer. It helps to reduce farm drudgery. Woman farmer can also operate it easily. The total cost of multi-crop planter, total fixed cost, variable cost and cost of operation is ₹ 2065, ₹ 4 and ₹ 65.08. The payback period of developed planter was found as 53.42 hours on hour basis and 6 ha on hectare basis. The benefit cost ratio in case of the developed multi-crop planter was found as 14.97 over a period of 10 years of the life of the planter.

## REFERENCES

- Anonymous (2011). Economic Survey of India [https://en.wikipedia.org/wiki/Economic\\_Survey\\_of\\_India\\_2011](https://en.wikipedia.org/wiki/Economic_Survey_of_India_2011) accessed on 28 June, 2018
- Bandhiya, R. D., Vadher, A. L., Parmar, N. B. & Mehta, T. D. (2016). Development and evaluation of manually operated seed drill for bajra crop. *International Journal of Science, Environment and Technology*, 5(6), 4630–4637. Breach Science publishers, New York.
- Donnel, H. (2001). Farm Power and Machinery Management, pg 127
- Ghosal, M. K. & Pradhan, S. C. (2013). Performance study on a low cost manually operated cup feed metering multi-crop planter for sowing green gram. *International Journal of Agricultural Engineering*, 37(1), 37-41.
- Indra Mani, Srivastava, A. P. & Panwar, J. S. (2006). Design and development of single row maize planter. *40<sup>th</sup> ISAE, Annual convention & symposium, January. TNAU, Coimbatore.*
- Lende, A. B., Sanglikar, R. V., Nalawade, S. M. & Kadam, P. B. (2011). Electronic metering mechanism for bullock drawn planter. *Green Farming*, 2(6), 739-741
- Rajaiah P., Indra Mani, Adarsh Kumar, Satish D. Lande, Roaf A. Parray, Ashok Kumar Singh and Cini Vergese. (2018). Comparative Study of Mechanical and Electronic Paddy Planter for Direct Seeding. *International Journal of Current Microbiology and Applied Sciences*, 7(09), 1284-1294. doi: <https://doi.org/10.20546/ijcmas.2018.709.153>
- Rao, E. K. (2006). Role of women in agriculture: a micro level study. *Journal of Global Economy*, 2(2), 107-118.
- Reddy, S. B., Satyanarayana., Adake, R.V. & Anantachar, M. (2012). Performance of seed planter metering mechanisms under simulated conditions. *Indian Journal of Dryland Agricultural Research and development*. 27(2), 36-42.
- Reddy, Sanjeeva, B., Satyanarayana, R. V., Adke & Anantachar, M. (2012). Performance of seed planter metering mechanism under simulated conditions. *Indian Journal of Dryland Agricultural Research and Development*, 27(2), 36-42.

- Sahoo, P. K. & Srivastava, A. P. (2008). Seed pattern characteristics of different metering system for soaked okra seed. *Journal of Agricultural Engineering*, 45(1).
- Sharma, D. N., & Mukesh, S., (2010). Farm Machinery design principles and problems (2nd ed.). New Delhi: Jain Brothers.
- Singh, M. K., Kumar, N., Verma, P. & Garg, S. K. (2013). Development and performance evaluation of manually operated no-till drill for chickpea. *Journal of Food Legumes*, 26(1-2), 83-85.
- Varshney, A. C., Tiwari, P. S., & Mehta, C. R. (2004) Data book for agricultural machinery design. *Central institute of Agricultural Engineering, Bhopal*.