

Morphology, Rehabilitation Architecture of zero slums in Bhubaneswar city, India

Abstract:

A slum is an unplanned and thickly populated residential cluster connoted with poverty and staggering livelihood in urban. Parameters of slums are poor services liveable structure, high density, hazardous location, health, education, and social exclusion secured of tenure. Present work involves the implementation of the zero slum concept of the sustainable development goal (SDG-11). It has been proposed to design and draw with the site plan prepared for 25 Blocks consisting of 998 units over 6.23 Acre and rehabilitate about 3000 slum dwellers out of about 7000 dwellers in distorted Kargil Baste in Bhubaneswar in central areas of BBSR between the airport and **south eastern railway line**. The methodology involves identification of present slums and the proposed rehabilitation area by GIS and RS approach, insitu demographic survey, soil survey, large map, and the design and drawing using AUTO CAD, STAD PRO, and scheduling by MS software. The cutting-edge concept of zero slums can be possible when part of the present slum areas are rehabilitated by the federal Municipal Corporation at zero cost houses, interim transits shed for newcomers, and provide affordable compartments at cost along with the redevelopment of existing slums giving land rights. **The fragmented cluster-wise rehabilitation as free allocation; at concessional price or sale at low-cost 2-BHK's are considered as choices.**

Keywords: Bhubaneswar; **Rehabilitation& resettlement**; Jaga Mission; SDG 11; **GIS/RS software**, Soil tests; Zero slums;

Introduction:

Odisha, one of the east coast states of India, is spread over 155706 Km², the 8th largest area-wise, and 11th population-wise. Culturally well recognized the state had Cuttack as the capital until 1950 according to good connectivity, economically hotspot, and historically, and politically important. But the rise in population, and want of extension, the new capital was found suitable near a city center on the land of temples, the Bhubaneswar. The extension was declared new Bhubaneswar, the capital city of Odisha, within the hills of Khandagiri and Udayagiri, encircled by the southerly Mahanadi branches, the Kuakhai, and the Daya. Quality water, air, and space for accommodation have forced its expansion and as of date it is a smart city mission, [1]; [2]; [3]

Initially, the city (Lat.- 20°19'N and Long. 85° 5'E) was planned to put up 40K people in 1946 by architect Konigsberg 1946 along with contemporary cities Chandigarh, and Jamshedpur. The 16.84km² space occupied has expanded today to ample space for horizontal/ vertical extension, healthy climate, quality of life, peaceful livelihood, infrastructure, moderate weather, federal transparency, and well communicated through NH 216 and 316, EC railways, and airport facilities. The area sprawled geo-spatially accommodating 1 million people has been exalted to a smart city in 2016 that becomes a center for higher education, astounding health care amenities, and a corporate hub, [4], [5].

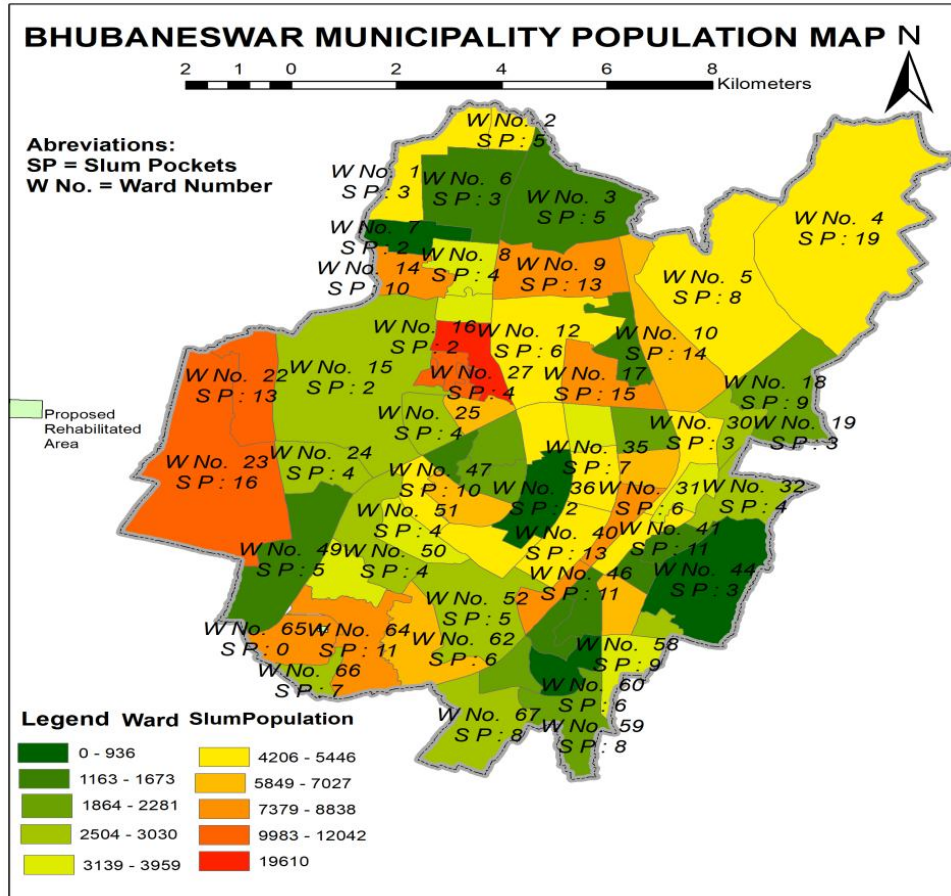

Fig 1: Population-wise slum area ranges in Bhubaneswar city as per the year 2008

Informal congested settlements in urban areas are slums. Slum dwellers live in unhealthy environments in un-hygienic conditions. They lack basic needs of life like food, sanitation, drainage, energy, health care, and government assistance. The slums flourish in cities poorly planned, lack jobs, meet the high cost of livelihood, and accommodate increasing migrants from rural areas. At times, natural disasters, urbanization, social exclusion, informal economy and vote bank politics, and social conflicts, [6].

Slums are indispensable and unavoidable for developing cities as they are a part of development through providing services. The temporary habitations near the huge constructions are deprived of sanitation, federal/ municipal privileges, worthy governance, connectivity, adequate electric connections, resourceful energy for usage, acceptable accommodation, health care, education, integrated public transport systems, and a tranquil healthy atmosphere to him and his family, [7], [8], [9]

The cause of the countryside people migrated to the capital city and created slums paucity of Land near the work site, urban poor's economic problems, Illegal settlement, getting new jobs, unemployment, natural calamity, and large family, indebtedness family conflict, losing earning member, high education, better health care, market, and higher aspiration.

Review of Literature

Chart 1: Population and Slum statistics of the Urban Local Bodies, Odisha

Zero slum concepts with clean energy provision are the sustainable development goals of the globe (SDG7 and SDG 11), India, the 2nd populous country has initiated by making greater Bombay, the cleanest city Indore, and the healthy city Bhubaneswar the flagship through India's smart city mission. The LAVASA, the eco-city on hills in Maharashtra, Rajarhat near Calcutta on swamps, Dolhara in Gulf of Khambhat, Rajsthan, and greenest city as Mysore, Delhi Chandigarh, Bangalore, and Bhopal, *etc.* have spectacular growth vertically and horizontally are attempted to follow the concept of zero slum in future years, [10], [11], [12] [Gupta et al., 2017](#), [Chowhan et al, 2022](#), [Pattanaik et al., 2022](#). The projection of city growth by 2050 shall be a concern to the middle and low-income countries with the burden of climate change (CC), food insecurity, poor health care, and housing infrastructure by 2050, [13] ([M. Vinod Ku et al., 2017](#))

The human and technology-centric smart city start-ups have pedestals such as people, economy, government, mobility/transportation, living standard, flexibility, and environment that can be classified as city and slum dwellers, [13], [14]. There recognized slums in Bhubaneswar are 436 numbers identified by BMC out of which 116 are authorized, and 320 unauthorized, [6]

The political interests undermined extortions to abolish, rehabilitate resettlement, or redevelopment of slums for slum squiring. Better accommodations are the choices for the urban poor. Abolish, or upgradation of slums have originated political conflict of interest among the local politician to satisfy their vote bank. The politicians at times use them to eliminate, relocate or rehabilitate the slums considering their ignorance during electoral process (Table 1).

According to the 2011 census, about 13.7mi households comprising 17.4% of the urban populace of India reside in slums. In Andhra Pradesh (AP), Chhattisgarh, Madhya Pradesh (MP), Odisha, and West Bengal, more than 1 out of 5 urban households live in slums. In Odisha, the average population of shantytowns is about 21.07% of the total. The population and the slum demography in different towns in Odisha (**Table 1**)

Slums statistics Odisha/ Bhubaneswar

The present Municipal commissioner at Bhubaneswar (BMC) is housed in an expanse of 135 km², comprising 67 wards. The city has a population of 885,363 people, with a 'slum' population of 163,983 people (18.5%) as per Census 2011. The capital city of Odisha tells the saga of three cities, i.e. the old city around the temple (pre-independence period), 2ndly the planned capital city from 1950 to 1980, and presently the expanded, 'unplanned' expansion in between. India is transforming from cosmopolitan to smart cities. Search for livelihood Indians is migrating from rural to urban.

Map 1: Located slum areas in different slums in Bhubaneswar (pink)

The disparity between the high cost of land, low income, and poor infrastructure in Bhubaneswar leads to slum generation. The world map with the location of the slum in Bhubaneswar is shaded pink. The formation of the slum began with temporary dwelling huts over the Huda of Jhar-Pokhari near the Pokhariput area (Unit 21) (Fig 2(a) and Fig 2(b)).



Fig 2(a): No proper drainage facilities



Fig 2(b): Housing Condition in Slum Area

The present work involves the rehabilitation of 1018 slum households with at least 3886 people living in an unhygienic environment, inadequate infrastructure, and a lack of basic services such as sanitation and safe drinking water facilities, [15].

Objectives

The scope and objective of the present study are to conduct a socio-economic survey of the shanty towns of Bhubaneswar, and the socio-economic and political settings of the slum residents. The role model is to ascertain and affirm the slum dwellers as per the improvement and clearance act 1973 for Karnataka state. The environmental impact studies (EIA) are conducted for the area clearance and redevelopment of slums in Bhubaneswar. As a solution to zero/redevelopment, alternate improved accommodation and infrastructural amenities with a conceptual model have been prepared to resettle, rehabilitate and redevelop slums identified with central, state assistance on partly financed, or public-private partnership (PPP) mode.

the re-settlement area should have provisions for basic amenities, like drinking water, street lights, roads, community health, hospital, drains, public lavatories, storm water drains, social security and community hall activities wherever promising. Access to the delivery of civil amenities as per the need is to be provided to the urban poor. The quality of life of the slum dwellers should develop through social awareness and community growth by employing NGOs.

Study Area

The 2nd largest shanty town in Bhubaneswar is the Kargil slum at 25° 2' N lat. and 88°9'0" E long that runs houses between the airport area and the east coast rail tracks leading to Khordha. Presently the base (ward No 62) has been expanded to an area of 18494m² and is under the governance of Bhubaneswar Municipal Corporation.

Kargil Bastee is housed within an abandoned stone quarry. It is a slum development within Bhubaneswar, with about 1018 households, and provides shelter to nearly 3886 people choosing from six clusters in the Pokhariput area. With little or no access except electricity and colony water supply, is available to cater to the basic services or government support human demands

for a comfortable livelihood. This cluster is chosen because of the old and the largest one, adjacent to the Biju Pattnaik International airport and habitat of antisocial.

The 3km long slum is crowded accommodating various groups of people of different caste creeds and colours. Urban Micro Business Centre is purposefully situated directly opposite the slum. The weather of Bhubaneswar is typically humid and tropical. Maximum temperatures rise as high as 45°C in May and June and fall to about 16°C in December and January. The average rainfall is 1505 mm. This area is mostly covered by laterite soil.

Table 1: Population and Slum statistics of the Urban Local Bodies, 2019 (BMC report) Odisha

Sl No	Ward No	Baste name	Slum Name	House Hold (No)	Population (No)	Reference
1	62	Kargil	Bhakta Madhu Nagar	153	587	BMC data 2019
2	62	Kargil	Kargil Baste	1018	3866	
3	62	Kargil	Kelasahi	327	1225	
4	62	Kargil	Ma Tarini Baste	96	359	
5	62	Kargil	Bhoi Baste	131	524	EB-851
6	62	Kargil	Tarini Baste	118	466	
Total in ward 62				1843	7027	

After the selection of the study area, the map is downloaded from the universal map downloader on that particular area and has done the digitization by Arc GIS. The survey involves exact households, schools, trees, roads, railway lines, etc. The project constitutes slum areas with irregular settlements of buildings and huts. The area has a high population density, unauthorized land occupations, hazardous infrastructures, and buildings that do not meet the basic livelihood standards like clean water, sanitation, women intimidation, geriatric negligence, and other social amenities under the pandemics 2019, [16], [17].

Methodology:

Rehabilitation Kargil slum area at GANGAPATNA needs immediately warranted for the safety of the international airport and the protection of Government land located at 13km distance from Khandagiri and adjacent to the ring road encircling BBSR. All the 7027 people shall be difficult to resettle at a stage. It is proposed to rehabilitate phase-wise so that planning can be done easily within the funds allocated by the Government. It has been proposed to design and draw with the

site plan prepared for 25 Blocks (998 units to be designed over 6.23 Acre). The disparity between the high cost of land, infrastructure, and lower incomes of migrants prefer to have slum creation. The present study envisages Rehabilitation and Resettlement of a Slum area of about 1018 households with at least 3886 people living in an unhygienic environment, inadequate infrastructure, and lack of basic services. The provisions emphasized are citizen services, sustained urban planning, mobility and green groundwork, and liveability Socio-physically, socio-spatially, and simultaneously the environment by the low-income resettlement models, [18], [19]. The procedures adopted are

1. Selection of area by GIS methods for finding the vacant and its dimensions for the expanse suitable for rehabilitation for optimum livelihood.
2. Demographic survey and analyze their economic status. in the slum area.
3. The exploration of the suitable soil of the area for the foundation of multistoried buildings along with the field reconnaissance survey.
4. Advanced survey for planning in a large-scale map of 1:1000 or 1:2000scale.
5. Designing and preparation of drawing for the resettled colony along with community services by using AUTO CAD.
6. The design of footings, columns, other beams, staircases, and slabs using the STAD-Pro software.
7. Since the Bhubaneswar area lies in the Zone III earthquake zone, the structures are earthquake resistance design.
8. The construction schedule is to be done for efficient construction planning.

The framework of the rehabilitation planning and design has been made based on the works of various authors, [20], and [21].

Rehabilitation destination:

The selected Slum area is KARGIL BASTE, Which is nearest to Biju Patnaik International Airport has been proposed to be rehabilitated to Ghangapatna Tehsil village which is about 15kms. It is completely a sparse bushy jungle area without private lands. Part of the existing slum needs to be rehabilitated in concessional payment mode or part subsidized mode to make the resettlement process easy and fast. The site plan for 25 Blocks (998 units over 6.23 Acre), design and drawing prepared. The project duration proposed is 40 Months (Fig 3(a) and Fig 3(b).

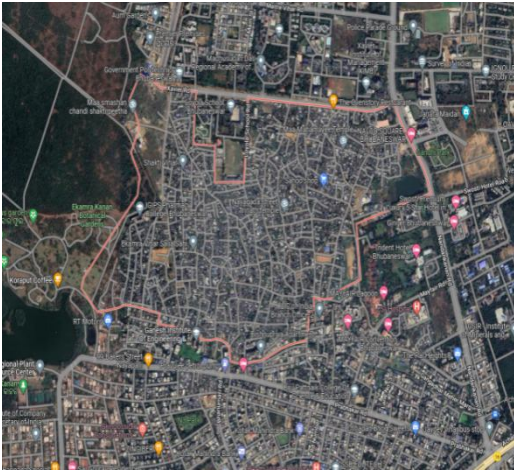

Fig: - 3(a) Rehabilitation place (Kargil Bastee) Fig 3(b):- Resettlement place Ghangapatna

Field Survey

The demographic survey of the present Baste has been taken up where the numbers of houses are counted with the number of males, females, and children below 15 years. The primary data was analyzed before advancing the rehabilitation scheme (**Table 2**).

Table 2: Insitu part of the field survey of the slum area needs to be rehabilitated (Kargil Bastee)

SL NO	OWNER'S NAME	DESIGNATION	MEMBERS	MALE	FEMALE	MONTHLY INCOME
RAY-01	PARBATI TUDU	LABOUR	3	2	1	13500
RAY-02	BANAMBAR PRADHAN	MISTRI	2	1	1	9000
RAY-03	PADMANAVA SAHOO	WORKER	3	2	1	13500
RAY-03A	HADUBANDHU PATRA	WORKER	5	3	2	22500
RAY-04	GOLARE TALE	HOUSE WIFE	6	3	3	27000
RAY-05	RAVICHAND	LABOUR	6	3	3	27000
RAY-06	HADUBANDHU PATRA	BUSINESS	4	2	2	60000
RAY-07	SHIVARAM PRADHAN	WORKERS	4	2	2	18000
RAY-08	TUNI ROUT	HOUSE WIFE	5	3	2	22500

Advanced survey

After downloading the satellite image from the universal Image downloader, the image was digitalized followed by buffering to acquire the buffered image finally. The houses, ponds, colonies, and roads are marked. The new area is in Fig 4 & Fig 5.

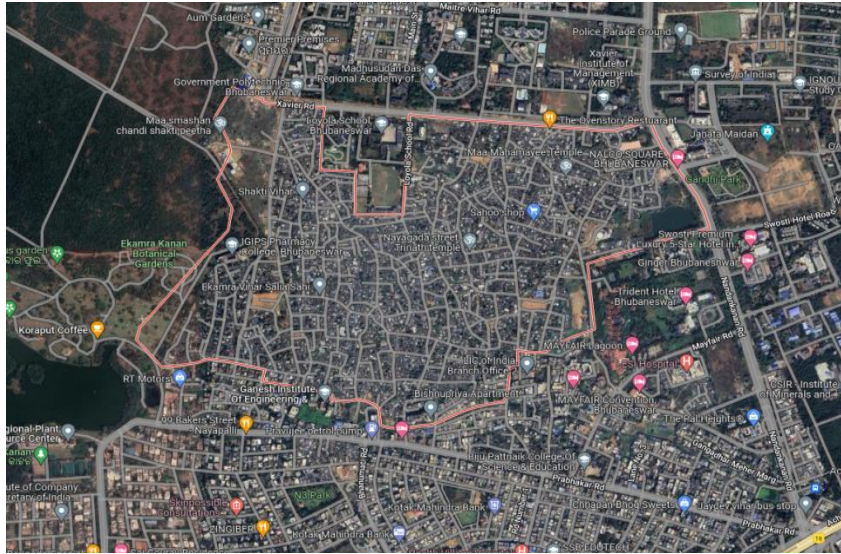

Fig: - 4 Digitization of the prosed area to be rehabilitated

Fig 5: The demographic survey of the proposed rehabilitation area in Ghangapatna

Water Content

The water a soil sample contains is its “soil moisture content”. The “Water content” is stated as a ratio that ranges from 0 (completely dry) to the value of the porosity of the material at saturation. The three samples obtained and have average water content obtained are 34.39%.

Fig 5: The demographic survey of the proposed rehabilitation area in Ghangapatna

Fig 6: The curve for moisture content vs. dry density.

Optimum Moisture Content (OMC)

The optimum soil water content is the amount of water when dry unit weight at maximum can be attained after proper compaction. A maximum dry unit weight should be of void soil. The optimum moisture content of the soil is determined in the laboratory by the Proctor Compaction Test (PCT). It is the stage at which the soil sample converted densest, and should gain its maximum dry density. The device is a Mold Diameter of 10.2 Cm, Height of 11.6 Cm, Volume of 944, Cc, and Weight of 4502 Gm., Weight 4502 Gm. (Fig 6) (Table 3)

Table 3: Bulk Density of the Soil 9n the proposed area of rehabilitation

Determination No.	1	2	3	4	5
Weight of water add, Ww(gm)	210	280	350	420	490
Weight of mold + compacted soil (gm)	6665	6796	6824	6810	6779
Weight of compacted soil, W(gm)	5721	5852	5880	58866	58835
Water add-in percentage (%)	6%	8%	10%	12%	14%
Bulk density (gm/cc) = W / (Mould volume)	6.06	6.20	6.23	6.21	6.18
Dry density (gm/cc) = Bulk density / (1 + w)	5.72	5.74	5.66	5.55	5.42

The average OMC = 12.90 and the Max Dry Density = 5.74

Unconfined Compressive Test (UCS)

Unconfined Compressive Strength (UCS) is the highest axial compressive stress that a specimen of a straight cylinder sample can bear under unconfined settings when the confining stress is zero. It is alternatively called the uniaxial compressive strength of that material as the imposition of the compressive stress is along one axis only, X-axis. (Table 4)

Table 4: Unconfined Compressive Test (UCS) of soil

Time (min)	Comp ⁿ Dial Reading (DL) LC =0.01 mm	Strain e =DL/L %	Area AC =AO /1.e (cm ²)	Ring Reading (1Div =1Kg)	Axial Load P (Kg)	Compression Stress P / AO (Kg/cm ²)
0	0	0	10.35	0	0	0
0.5	100	1.32	11.5	1	1	0.09
1	200	2.63	11.6	2	2	0.17
1.5	300	3.46	11.82	3	3	0.26
2	400	5.28	11.98	5	5	0.42
2.5	500	6.58	12.15	7	7	0.58
3	600	7.9	12.32	9	9	0.78
3.5	700	9.21	12.5	11	11	0.83
4	800	10.53	12.69	12	12	0.95
4.5	900	11.34	12.87	13	13	1.01
5	10000	13.16	13.09	14	14	1.07
5.5	1100	14.47	13.37	14	14	1.06

6	1200	15.79	13.48	13	13	0.96
---	------	-------	-------	----	----	------

Weight of Sample = 435.27gm; Unconfined compressive strength $q_u = 1.07$ (kg/cm²) and Shear Strength of the soil, $C_c = q_u/2 = 0.535$ (kg/cm²)

Safe Bearing Capacity

The capacity of the soil that supports the structural load to the ground without any shear failure or settlement is called the safe bearing capacity of the soil. The safe bearing capacity of soil = Ultimate bearing capacity (UB)/(Area x Factor of Safety) **(Table 5), (Table 6), (Table 7)**

Table 5: Property of the safe bearing capacity of the soil of the proposed area of rehabilitation

Properties	
Cohesion	0.48kg/cm ²
The angle of Internal Friction	8 Degree
Dry Density	1.541 in gm/cc
Specific Gravity	2.551
Coefficient of volume change (mv)	0.0128
Factor of Safety	2.81
“e”, Void ratio	0.655 Computed
Shear Failure Type (taken)	Intermediate

Table 6: Safe Bearing Capacity and Safe Bearing Pressure of the Ghangapatana Soil sample

Type	Size (m)	Depth (m)	SBC in t/m ²	100 mm permissible (SBP) settlement (t/m ²)	Suggested SBC for the design of foundation (t/m ²)
RCC Raft Footing	Dia=16.0	2.25	16.30	+19	16.30
		2.5	16.48		16.48
		3	16.85		16.85

Table 7: The table showing the characteristics of the soil at Ghangapatana, near Bhubaneswar

The characteristic of the Parameter	The average results
Soil Type	Laterite
Water content	34.39(%)
Specific gravity (sp. Gr)	2.81
Max dry density (MDD)	5.75

Optimum dry density (OMC)	12.9
Unconfined compressive strength (UCS)	1.07 kg/cm ²
Shear strength of the soil	0.535 kg/cm ²
Grain Size Distribution	Gravel = 36.6 %; Sand = 63.2 %; Fines = 0 %
SBC for Raft Foundation depth above 3m	16.6 T/m ²

The Plan of a single dwelling unit, a single complex, and the site layout plan are given in Fig 7(a), Fig 7(b), and Fig 7(c). The section plan of the Mat foundation in a single unit in the resettled village and the section plan of the footing in the raft foundation in the resettled housing are in Fig 7(d), and Fig 7(e)

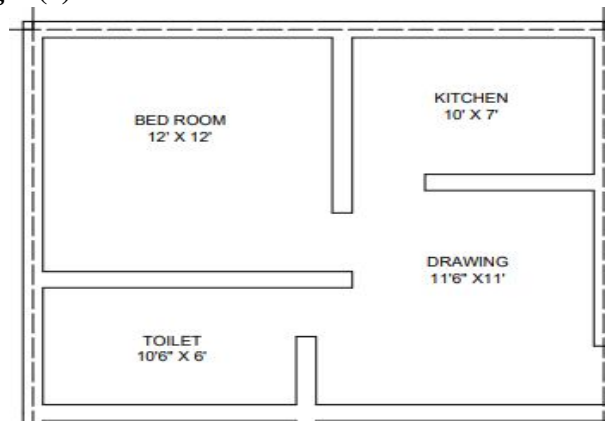

Fig 7 (a): One single dwelling unit in the resettlement colony



Fig 7(b): One single dwelling floor in the resettlement colony at Ghangapatna

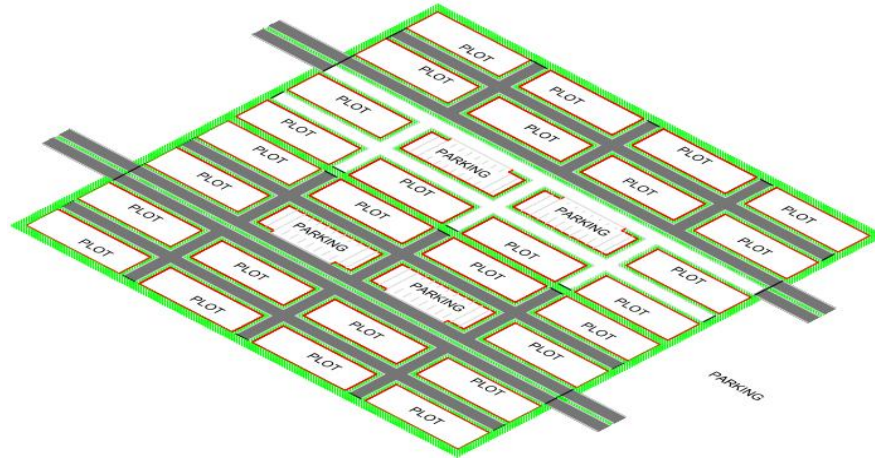

Fig 7 (C): The site layout plan at Ghanga Patna, in Bhubaneswar (Resettlement colony)

Design and Detailing

Foundation

Mat foundation has been provided in this structure because the bearing capacity is poor. SBC is 16 T/m² and the axial load build-up is 881kN, the mat foundation is adopted. The foundation supports the entire building load and safely transfers it to the ground. Details of the foundation positions are given in Fig 7(a), 7(b), 7(c), 7(d), and 7(e)

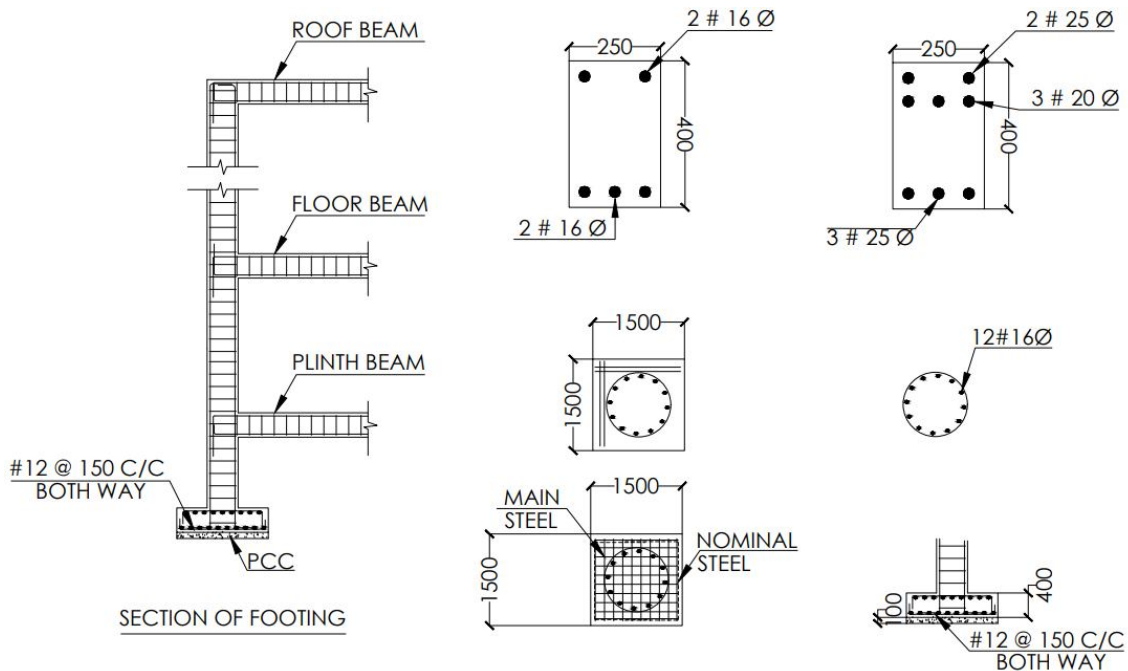

Fig 7 (d): The section plan of the footing in the raft foundation in resettlement units

Fig 7 (e): The section plan of the Mat foundation in a single unit in resettled village

Beam

A beam is the RCC structure that primarily takes lateral loads to the axis of the beam when the mode of deflection is mainly bending. The loads on the beam result in the reaction forces at the junction where the beam is supported. The resultant of the forces acting on the beam produces a shear force (SF) and bending moment (BM) within the beam.

Beam details

The dimensional size of the beam is 0.380 X 0.500 m, whereas the size of the stirrup is 0.28 x 0.41 m. The reinforcement details are : Top bar = 2 @ 18mm dia; Bottom bar = 2@ 18mm dia; Mid bar = 2@ 10mm dia; Stirrups = 10mm Dia @ 180mm c/c, 2 legged

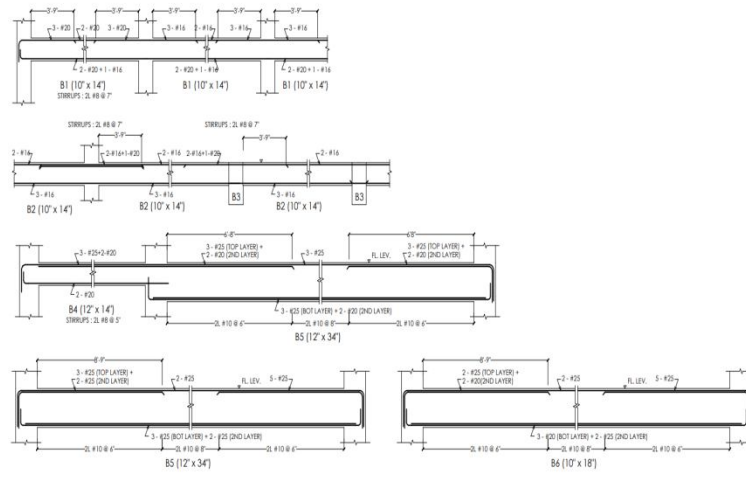

Fig:- 8: Sectional of Beam of the proposed structure

Column

A column in a structure is the component that transmits, the weight of the overload above to other structural components below through compression. A column is a compression member in a structure. The column transmits the overhead structure load to the base which may be made of stone, brick, or RCC Fig 9(a) and Fig 9 (b).

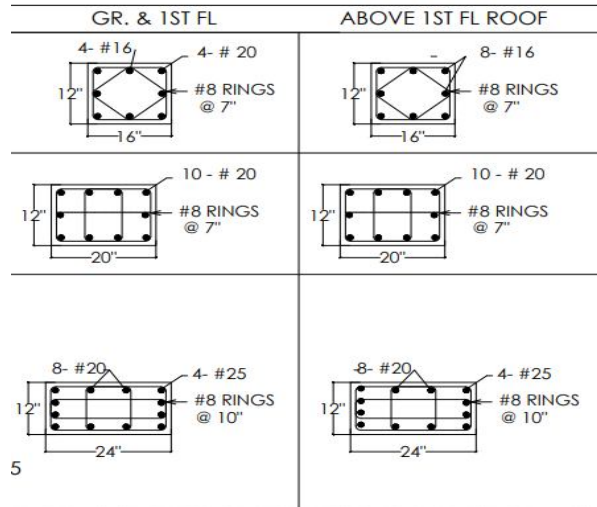

Fig 9(a): The columns' position, sizes, (b) Reinforcement details, in-ground, and floors

Column details:

The size of the column is 0.300 x 0.460 m; The size of stirrup is 0.230 x 0.380 m, 0.380m, 0.220 x 0.230 m. Reinforcement Details are (i) Total = 12 # 20mm dia (b) Stirrups = 10mm Dia @ 200mm c/c

Staircase Details

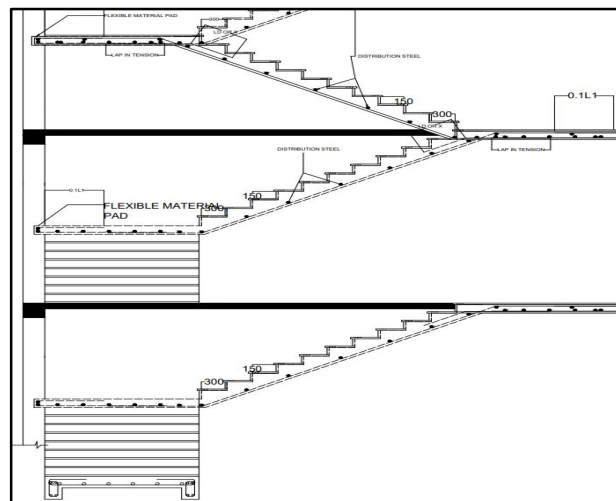

Fig 10: Section of Staircase of the proposed building

A staircase connects places between two elevations that is designed to bridge two altitudes of a structure by dividing the height into smaller heights, called steps. Stairs may be straight, round, or may consist of two or more straight pieces connected at angles depending upon the designer's choice (Fig 10).

Slab Details

A cement concrete slab is the structural part of buildings, comprising of a flat, horizontal surface made of cast concrete. The slabs are of steel reinforcement of 100 and 500 mm thick and are often used to make floors and ceilings, Fig (11).

Fig 11: The various Bending Moment areas of the slab

The Ultimate moment is 2 kN/m. The details of reinforcement provided are 8mm ϕ @ 200mm c/c, the clear cover is 15mm and the thickness of the slab is 150mm.

Dead load & Live load Calculation

Table 8: Self-weight calculation of the individual components of structures

#	Structural component	Wt of load	Calculation	design load
1	The beam & column (Taken by software)	Self-weight	$0.5m \times 0.3m \times 1m \times 25kn/m^3$	3.75kn/m ³
2	The slab	Self-weight	$0.152m \times 25kn/m^3$	3.8kn/m ²
3	Floor finishes	Dead Load	1kn/m ²	1kn/m ²
4	Furniture & equipment	Dead Load	1kn/m ²	1kn/m ²
5	Total dead load given	Dead Load		5.8Kn/m ²
6	Total Live load	Live Load	As per IS-875 Part 2	3kn/m ²

Seismic Load Calculation

- The earthquake impact on construction is subject to the stiffness of the structure, soil media stiffness, tallness, and position of the structure. (Table 8)
- Bhubaneswar belongs to zone II. Annex E, of IS-1893(part -1):2002
- Zone factor, $Z = 0.16$
- h = total elevation of the construction
- Time in x direction, $T = (0.075 * h) * 0.75$

Wind Load Calculation

- Wind load is subject to the velocity of the wind at the location, and the height of the structure Wind analysis is done based on the recommendation given in (IS-875(part 3),1987)
- The design wind speed can be calculated as : $V_z = V_b * K_1 * K_2 * K_3$

Where V_b –wind speed in m/s; V_z – design wind speed at height z in m/s;

K_1 – risk factor; K_2 - factor for designing wind speed; based on structural elevation & land; K_3 - factor of topography

From IS code, Basic wind speed V_b -50m/s, for Bhubaneswar, and K_1 -1.08 & K_2 -1.12 (the territory is category-2) K_3 =1. Hence; Design wind speed = $50\text{m/s} \times 1.08 \times 1.12 \times 1 = 60.48\text{m/s}$ (Fig 12) [Appendix A, IS-875(part 3), 1987],

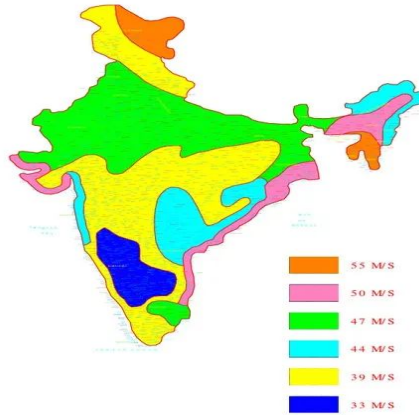

Fig 11: Wind speed at Bhubaneswar and various zone in India



Fig 12 (a): The side view of the proposed Unit Fig 12 (b): The back view of the proposed unit



Fig 12 (c): The back view of the proposed unit
 In the wind speed diagram, the different views of the building are given in Fig 11, Fig 12 (a), Fig 12 b), and fig 12 (C).

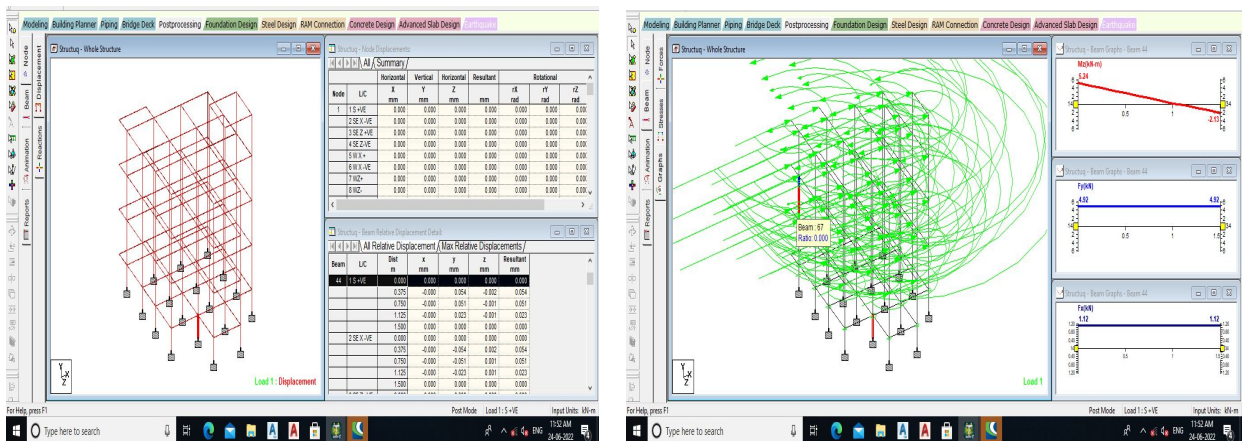
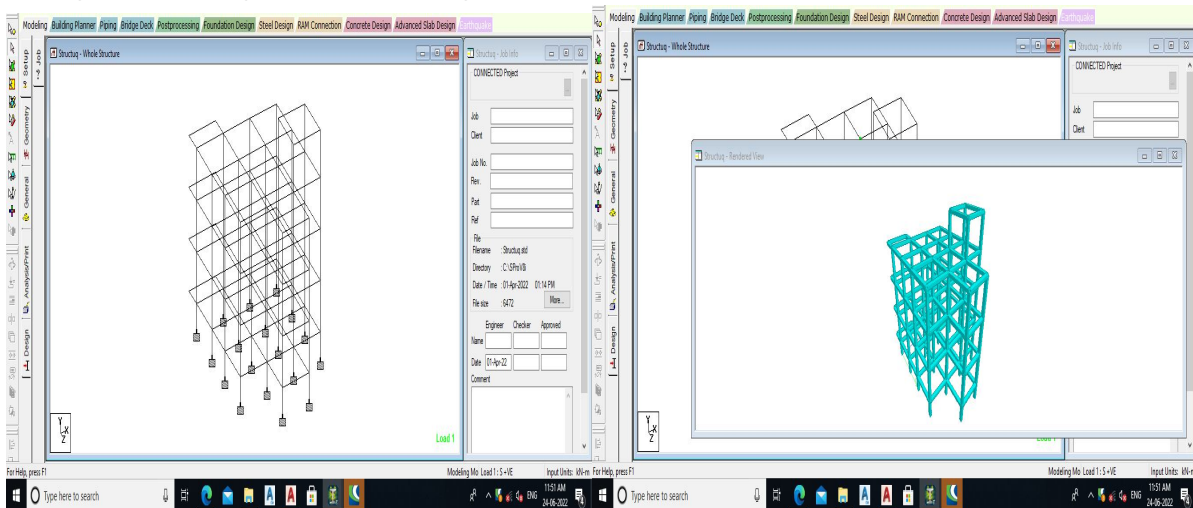

Fig 13: The base shear response of the model subjected to wind forces and earthquake tremors (Grid presentation, 3D diaphragm, Post processing-displacement vs. Load, wind effect),

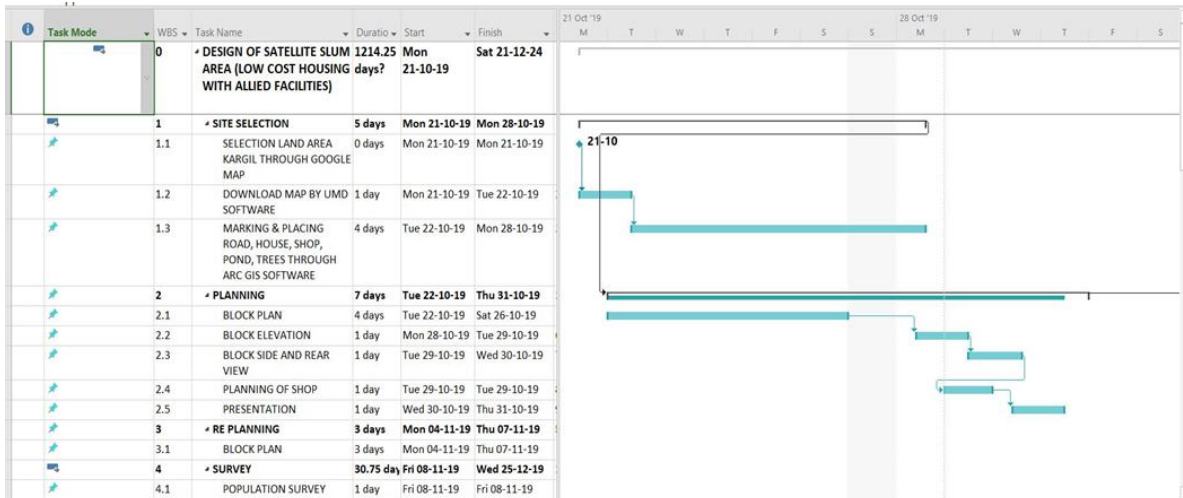

Fig 14: The scheduling of the future building for a project duration of 3 Years 4 Months

The base shear response of the model subjected to wind forces and earthquake tremors (Grid presentation, 3D diaphragm, Post processing-displacement vs. Load, wind effect) are in fig 13 and the scheduling is in fig 14.

Results and Discussion:

India is transforming from cosmopolitan to smart cities. Search for livelihood Indians is migrating from rural to urban. With one thousand million slum dwellers in the world, India contributes 35.2% of its total population warranting to focus (as per SDG 7 for adequate affordable, modern, and clean energy & SDG 11 for sustainable cities and communities with zero slum concept) on the affordable house, livelihood, education, health security, amenable basic services, transport, mobility, and safety but under threat [22] (Quadeer et al., 2022). Energy supply is not clean as 60% of GHG emissions are accounted on date and 1.7% from renewables globally [23-27].

To attain a low carbon economy and initiatives demand attempts to invite emerging climate initiative innovations. Urban slums add to the GHG, waste pollution, and environmental degradation, (<http://wdi.worldbank.org/table/WV.3>). Cape Town and Bombay city attempts with zero slums may be costly as federal initiatives. But isolated and part promotion through public awareness, promoting dialog, PPP mode, big data dissemination, and concerted practices of urban planning can be efficient, fast, and cost-effective, [28-35].

To make the city Bhubaneswar smart, it must have innovations in its constructions, roads, digital technology, economic growth, safe livelihood, good society and environment, and above all achievements in quality of life, [36]. Slums are the initial basement for immigrants' low-cost, affordable shelter without a settled establishment for themselves and their families. This is a vibrant place for the amalgamation of various people from cast, creed, and color, slums give chance to its people multiple cultures struggling to make an honest living, vibrant lifestyle, under broad urban poverty and formal employment. With all odds, they develop economic rationality and novel dwelling solutions, [37]

Slums are excruciating housing for the urban poor, unsafe, dearth of rudimentary services, unsafe shanty dingy houses, overcrowding, built up over menacing land. These fragmented families, have most of their members' un/underemployed, and economically backward, physically, and socially excluded. Shantytown people have restricted access to credit and formal job markets due to stigmatization, discrimination, and geographic isolation. These dingy towns are recipients of the capital's nuisances, industrial effluents, and noxious waste. The only land available to slum occupants is most cases fragile, dangerous, disorderly, or polluted for land-dwelling and mobility ([25], [23], and [27]).

This can be ameliorated through upgrading slums, rehabilitating, redressal of poverty, room for newcomers, low wages, structuring urbanization and economy, creating job opportunities, legitimizing slums, and planning for both urban and rural areas. Collaterally planning for rural changes side by side with urban expansion with economic development is warranted in the present scenario[28][29] (UN -2016, Mishra et al, 2020).

Affordable lodging has become the foremost concern in the metropolises. BMC (Bhubaneswar Municipal Corporation) has been in pipeline progress to provide reasonably priced housing to slum dwellers or at concessional rate or giving property rights under the JAGA mission in Odisha. The total shantytown inhabitants of the state constitute 3.7% of its total population, comparably lower than other states in India. The JAGA Mission is covering 1.7mi slum inhabitants gradually mainstreaming dingy bastee through a combination of land rights and shelter.

Conclusion:

Slum Progression in BBSR is questioned today as a Problem or solution. Slum-less urban agglomeration needs adaptation to waste spills, environmental degradation, response to shocks, and stresses that shall lead to sustainable, resilient, tranquil, and address inequality, social Stability, informality, insecurity, and climate change issues related to a slum-less urban agglomeration with the innovative digital world. SDG 11 stresses teamwork and alliance, planning and scheduling, authoritative governance, fiscal policies, and learning that can sustain positive change.

Slums are indispensable /unavoidable for emerging cities as they are a part of development as their dwellers provide service providers. They have temporary habitations near the huge constructions only to save time on transportation. They are deprived of sanitation, civil liberties, worthy governance, connectivity, energy availability, acceptable lodging, health care, education, public transport, and a healthy atmosphere for themselves and their family.

Reference:

1. Mishra S. P., Nail A., 2015, Time series Analysis of monsoon precipitation of Bhubaneswar, Odisha, Conference Paper, Recent Advances and Future Prospects in Civil Engineering, RFAPC-15

2. Joshi A., Mishra S. P., (2017), Anthropocene Effects on the River Daya and the Lagoon Chilika by the Effluents of Bhubaneswar city India: A physic-chemical study, *International Journal of Advance. Res.*, 5(10), - 1370-1384, <http://dx.doi.org/10.21474/IJAR01/5656>
3. Biswal R., Mishra S. P., Pattnaik G. D., 2019, Environmental sensitization of BMLW of Anthropocene epoch: in developing township: Bhubaneswar, India, *Int. Jour. of Chem Tech Research* 12(04), 127-149, DOI: 10.20902/IJCTR.2019.120417
4. Das Chatterjee, N., Chatterjee, S., Khan, (2016). A. Spatial modeling of urban sprawl around greater Bhubaneswar city, India. *Model. Earth Syst. Environ.* 2, 14, <https://doi.org/10.1007/s40808-015-0065-7>
5. Panda, S., Mallik, C., Nath, J., et al. (2021). A study on the variation of atmospheric pollutants over BBSR during the imposition of nationwide lockdown in India for the COVID-19 pandemic. *Air Quall Atoms Health* 14, 97–108, <https://doi.org/10.1007/s11869-020-00916-5>.
6. Annand, G., Deb, A. (2017). Planning, 'Violations', and Urban Inclusion: A Study of Bhubaneswar. YUVA and IIHS. New Delhi.
7. Singh K., Sharma. N., Gunnar, P., (2017). Smart cities in India: key areas and challenges – a case study of Chandigarh city, *IJMSS*, 4(1), 1-12
8. Rana, NP, Lutheran, S, Mangle, SK, Islam, R, Roderick, S., Dived, YK. (2018). Barriers to the Development of Smart Cities in Indian Context, *Information Frontiers*, Springer, 1-14, <http://usir.salford.ac.uk/id/eprint/48532/>
9. Mishra S. P., Sethi K. C., (2020). Micro Level Search for COVID-19, Bhubaneswar: Odisha, India; *Current Journal of Applied Science and Technology* 39(34):143-163, DOI: 10.9734/CJAST/2020/v39i3431045
10. Gupta K., Hall, R. P., (2017) The Indian perspective of smart cities, in 2017. *Smart City Symposium Prague (SCSP)*. IEEE, 2017, pp. 16.
11. Chowhan, G., Sen, A., Mukherjee, J.,(2022). Sustainable and ‘smart’ restructuring around the making of mega and world-class cities in India: a critical review. *Geo Journal*. <https://doi.org/10.1007/s10708-022-10644-1>
12. Patnaik, S., Sen, S., Ghosh, S. (2022). Introduction. In: Patnaik, S., Sen, S., Ghosh, S. (eds) *Smart Cities and Smart Communities*. *Smart Innov. Sys. and Tech.*, 294. Springer, Singapore. https://doi.org/10.1007/978-981-19-1146-0_1
13. M. Vinod Ku., Dahiya, B., (2017). Smart Economy in Smart Cities. Book: *Smart Economy in Smart Cities*, 1stChapter: Springer Editors: T. DOI: 10.1007/978-981-10-1610-3_1
14. Attaran H, Kheibari N, Bahrepour D., (2022). Toward integrated smart city: a new model for implementation and design challenges. *Geo J...*1-16. doi:10.1007/s10708-021-10560-w.
15. Bhubaneswar Municipality, 2008, Slums Details, Bhubaneswar, Housing and Slum Population In Bhubaneswar.
16. Friesen J, Friesen V, Dietrich I, Pelz PF. (2020). Slums, Space, and the State of Health—A Link between Settlement Morphology and Health Data. *Int. J. of Environmental Research and Public Health*. 2020; 17(6):2022. <https://doi.org/10.3390/ijerph17062022>

17. Kumari A, Panigrahi A, Roy A, Panda J. Impaired quality of life and its determinants among postmenopausal women of slum communities in Bhubaneswar, India. *J Mid-life Health* 2020;11:149-55
18. Sarkar A, Bardhan R. Socio-physical liveability through socio-spatiality in low-income resettlement archetypes - A case of slum rehabilitation housing in Mumbai, India. *Cities*. 2020 Oct;105:102840. doi: 10.1016/j.cities.2020.102840.
19. Delhi University, (2022). Challenges to Disaster Risk Reduction and Resilient Habitat. Int. conf. The topic "Challenges to Disaster Risk Reduction and Resilient Habitat" on 5th to 6th April 2022, Sahid Bhagat Singh College, organizer, CDMS.
20. Sumanth, M.K., Sridevi B., Babu R.S., (2017), slum rehabilitation planning and analysis using AUTOCAD and GIS in Greater Visakhapatnam Municipal Corporation, Andhra Pradesh, *J Remote Sensing & GIS* 2017, 6(4), DOI: 10.4172/2469-4134.1000220
21. Mishra S. P., Nayak S. Pr, Mishra S., Siddique Md., Sethi K. C., (2019), GIS And auto desk modeling for satellite cities around Bhubaneswar, *Int. J. of Innovative Technology and Exploring Eng. (IJITEE)*,8 (11), 297-306
22. Qadeer A, Anis M, Ajmal Z, Kirsten KL, Usman M, Khosa RR, Liu M, Jiang X, Zhao X. Sustainable development goals under threat? The multidimensional impact of COVID-19 on our planet and society outweighs short-term global pollution reduction. *Sustain Cities Soc.* 2022 Aug;83:103962. doi: 10.1016/j.scs.2022.103962.
23. Shekhar, S. (2021). Urbanization in India. In: *Slum Development in India. The Urban Book Series*. Springer, Cham. https://doi.org/10.1007/978-3-030-72292-0_1
24. Leavesley A, Trundle A, Oke C. Cities, and the SDGs: Realities and possibilities of local engagement in global frameworks. *Ambio*. 2022 Jun;51(6):1416-1432. doi: 10.1007/s13280-022-01714-2.
25. UN Habitat, (2003). *The Challenge of Slums: Global Report on Human Settlements 2003*. Earthscan Publications Ltd, London, and Sterling, VA, 1-345
26. Mishra, S., Sahoo, GC., Mishra, s. P., Sethi, KC, Md. Siddique. (2020). From squatter slums to modeled dwellings in Anthropocene: Bhubaneswar, India. *Int. J. of Eng., and Adv. Tech. (GREAT)*, 9(3), 2783–2793. <https://doi.org/10.35940/ijeat.C5935.029320>
27. Dey C. K., Mishra S.P., Barik K.K., Sahu, D. K., (2022), Shaping Smart City transportation with Traffic Congestion Solutions: Bhubaneswar, Odisha, *Current Journal of Applied Science and Technology*41(7): 45-60, Article no.CJAST.85664ISSN: 2457-1024; past: 2231-0843,NLM ID: 101664541)
28. United Nations, (2016). *Urbanization and Development: Emerging Futures. World Cities Report*. UN Publication; New York, NY, USA:
29. Mishra, S., Sahoo, GC., Mishra, s. P., Sethi, KC, Md. Siddique. (2020). From squatter slums to modeled dwellings in Anthropocene: Bhubaneswar, India. *Int. J. of Eng., and Adv. Tech. (GREAT)*, 9(3), 2783–2793. <https://doi.org/10.35940/ijeat.C5935.029320>
30. Livengood, A., Kunte, K., (2012). Enabling participatory planning with GIS: A case study of settlement mapping in Cuttack, India. *Environ. Urban.* 24, 77–97 (2012).

31. Patel, S., Baptist, C., Cruz, C. D., (2012) Informal communities assert their right to the city through SDI and community-led enumerations. *Env. Urban.* 24, 13–26 (2012).
32. Andavarapu, D., Edelman, D. J., (2013) Evolution of slum redevelopment policy. *Curr. Urban Stud.* 1, 185–192
33. Nuaimi, EA., Neyadi, HA, Mohamed, N., Jaroodi JA.,(2015). Applications of big data to smart cities. *J Internet Serv Appl* 6, 25. <https://doi.org/10.1186/s13174-015-0041-5>
34. Brelsford, C., Martin, T., Hand, J., Bettencourt, LMA., (2018), Toward cities without slums: Topology and the spatial evolution of neighborhoods. *Science Advances*,
35. Tan, R.K.J., Wu, D., Day, S., Zhao Y., et al.(2022). Digital approaches to enhancing community engagement in clinical trials. *npj Digit. Med.* 5, 37 (2022). <https://doi.org/10.1038/s41746-022-00581-1>
36. Dashkevych, O.; Portnov,BA., (2022). Criteria for Smart City, Identification: A Systematic Literature Review. *Sust.*, 14, 4448. <https://doi.org/10.3390/su14084448>
37. Mahabir, R., Agouris, P., Stefanidis, A., Arie Croitoru, Andrew T. Crooks. (2020) Detecting and mapping slums using open data: a case study in Kenya. *International Journal of Digital Earth* 13:6, pages 683-707.